



# Series e-80X Smart Pumps

Integrated pump, motor & variable speed drive solutions,  
powered by hydrovar<sup>®</sup> X

# Contents

General Introduction .....	3
Applications and Benefits.....	4
Performance Coverage at 60 Hz, 2-poles and 4-poles .....	5
Assembly Configurations .....	6
Specifications Document List .....	9
Electrical Data .....	10
Terminal Block .....	15
How to Read Smart Pump Series Curves .....	16
Performance Curves for High Speed Models - 460V .....	17
Performance Curves for High Speed Models - 230V .....	34
Performance Curves for Low Speed Models .....	43
Materials of Construction.....	67
Seal Assemblies.....	67
Dimensions .....	68

## General introduction

Powered by Xylem's hydrovar® X Smart Motor, Series e-80X Smart Pumps offer customizable pumping solutions designed to deliver ultra-premium efficiency, connectivity, and simplicity right out of the box!

Series e-80X Smart Pumps integrate decades of expertise and know-how in pumping solutions to bring the right combination of motors, variable speed drives and hydraulic pumps in one comprehensive, highly efficient package. Series e-80X Smart Pumps reduce electricity consumption, improve overall system performance, and lower life cycle costs. The extensive energy saving profile enables users to maintain significantly higher levels of efficiency over a much wider range of operating conditions. Designed for horizontal and vertical in-line mounting, it's ideal for hydronic heating and cooling systems, light industrial processes and general service.

So, when it's time to think efficiency, performance and reliable market-leading technology ... start with Series e-80X Smart Pumps from Bell & Gossett – a complete system, delivering the solutions you need for today.

## Hydraulic specifications

- **Maximum flow:** up to **1400 GPM**
- **Maximum head:** up to **428 ft TDH<sup>1</sup>**
- Hydraulic performance compliant with **ANSI/HI 14.6 Grade 2B**
- **Maximum temperature:** up to 250 °F (121 °C)
- **Maximum working pressure:** 175 psi (12 bar)<sup>2</sup>

<sup>1</sup> The 1.5x9.5B model may exceed the nominal 175 psi rating when operating above 3600 RPM in low-flow conditions. For reliable operation, observe the recommended maximum speed limits indicated on the individual performance curves and adjust the motor speed to avoid exceeding the 175 psi maximum working pressure.

<sup>2</sup> See mechanical seal options for temperature limitations.

## Motor specifications

hydrovar X

- IES2 Power drive system (PDS) efficiency (IEC 61800-9-2:2017)
- IE5 Motor efficiency (IEC TS 60034-30-2:2016)
- NEMA 4
- Insulation class 115 (Class F)
- Totally enclosed fan cooled (TEFC) construction
- 3-Phase power supply
- Rated speeds (high speed models): 3000 - 4000 RPM<sup>3</sup>
- Rated speeds (low speed models): 1500 - 2000 RPM<sup>3</sup>
- High speed models: 3 kW to 22 kW (4 HP to 30 HP): 200-240V and 380-480V +/- 10%, 50/60Hz
- Low speed models: 1.5 kW to 11 kW (2 HP to 15 HP): 200-240V and 380-480V +/- 10%, 50/60Hz
- RS485 Communication interface, BACnet and Modbus standard and BLE included
- Overload and locked rotor protection with automatic reset included
- Multi-pump linking (up to 8 pumps)

<sup>3</sup> Rated speeds are used to determine the net efficiency of a pump-drive system and for energy efficiency listings. Pumps may or may not utilize the full speed range of hydrovar X depending on a variety of factors or limitations. Models may operate below rated speed at partial loading. See individual performance curves for more detail.

## Applications

The **Series e-80X** is suitable for the following applications:

- Chilled Water
- Commercial HVAC
- Hydronic Heating and Cooling Systems
- Cooling Towers and Industrial Uses
- Pressure Boosting
- General Liquid Transfer

### Pumped Fluids

- Unheated domestic and fresh water
- Boiler feed water
- Condensate
- Benign liquids

## Benefits

The **Series e-80X** provides the following benefits:

**Ease of installation and maintenance:** the integrated pump and hydrovar X motor package eliminates additional wiring, labor, and costs associated with a traditional variable frequency drive (VFD) package. The hydrovar X motor features a quick-connect electrical socket between the motor and drive for rapid maintenance.

**Intelligent performance:** advanced control systems embedded within the hydrovar X motor are customizable for a wide range of applications and multi-pump support (up to 8 pumps) for parallel pumping installations.

**Simple:** the hydrovar X motor is easy to configure and commission. Follow the start-up genie to quickly tailor the motor to its intended application. Control selections and navigate menus via a full color graphical display.

**Built-in protections:** integrated functions protect the pump and motor when operating near the current and power limits of the system.

**High efficiency:** the IE5 “ultra-premium” hydrovar X motor provides one of the broadest efficiency ranges in the industry.

# Performance Coverage at 60 HZ, 4000 RPM

## e-80X High Speed Hydraulic Performance

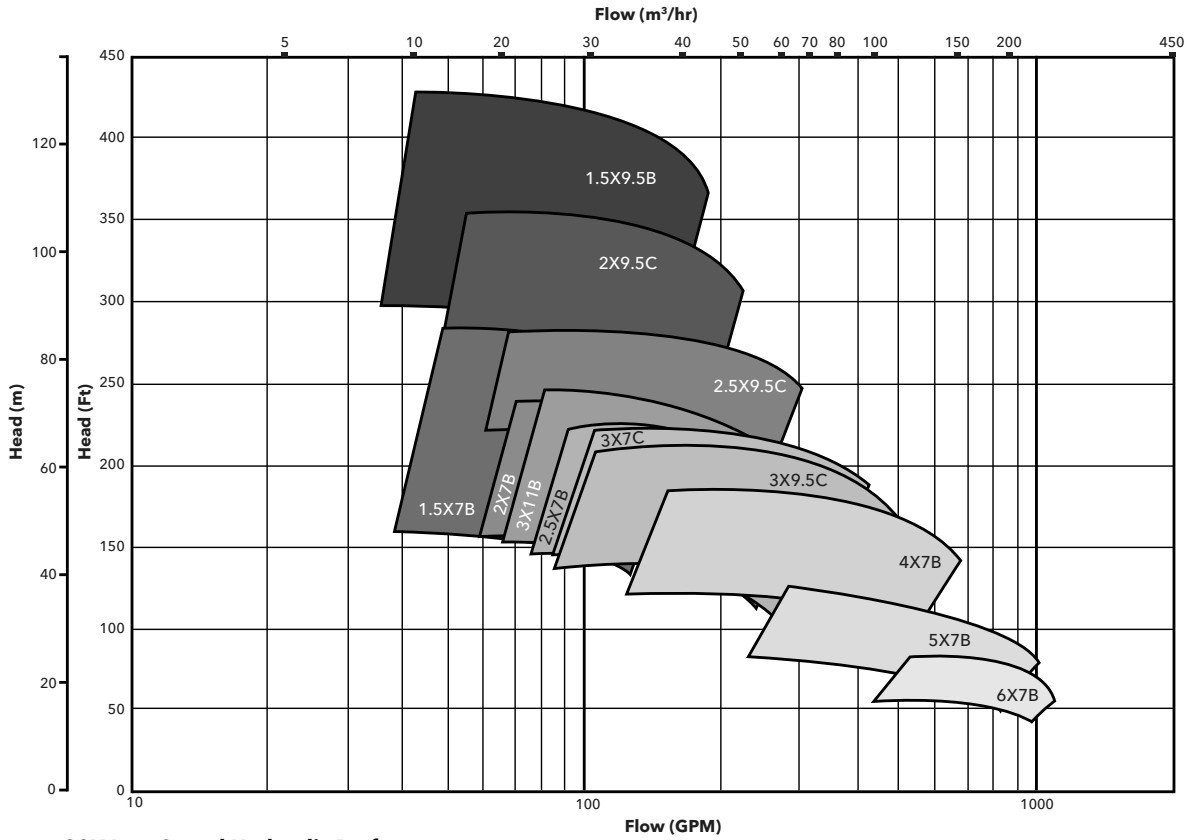

## e-80X Low Speed Hydraulic Performance

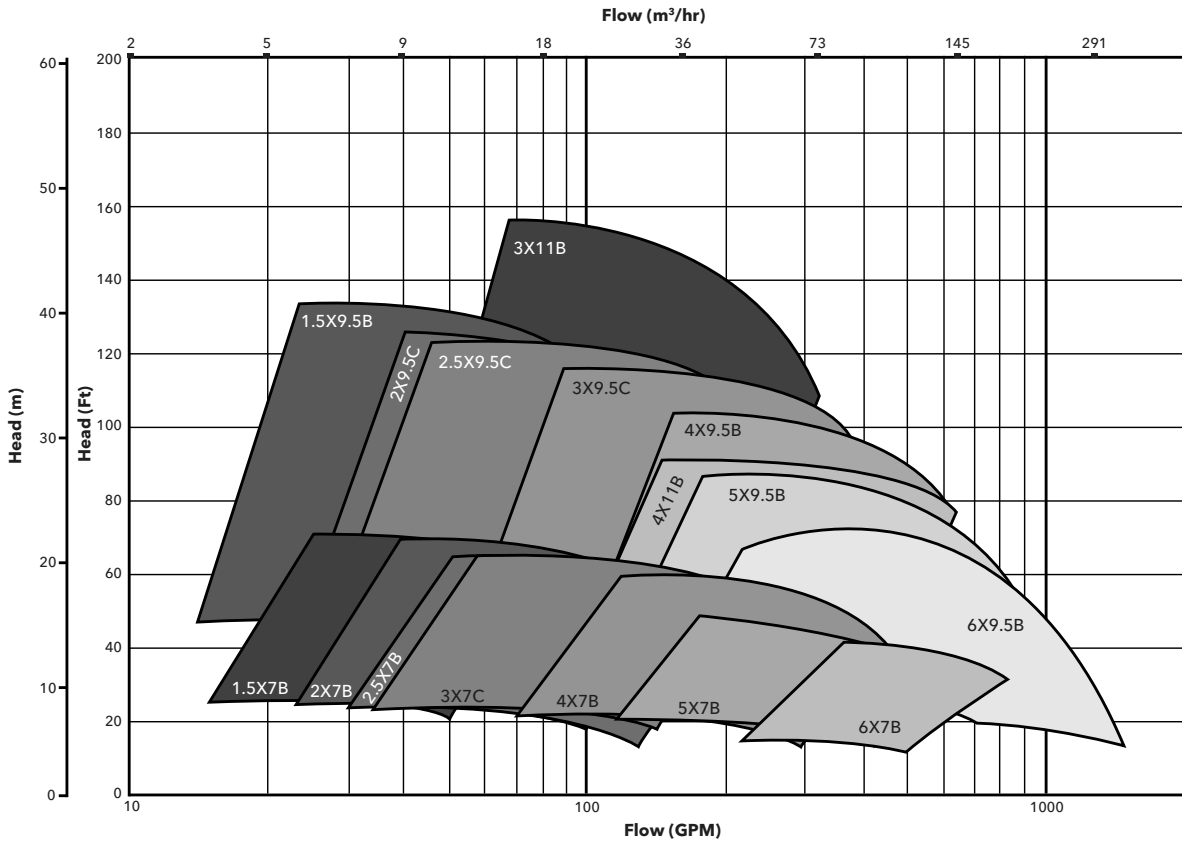

**Series e-80X  
Assembly Configurations**

**High Speed (800-4000 RPM) 3 Phase - 380-480V (460V Nominal Voltage)**

Pump Size	Motor Code	Motor Type	BUNA/C/SiC	EPR/C/WC	EPR/SiC/SiC	Motor HP	NEMA Frame	Impeller Trim (in.)
1.5x1.5x7C	130636370	EXM213-215/4.150CH2	80X157CGMTXW	80X157CGMTXY	80X157CGMTXZ	15	213JM	7
1.5x1.5x7C	130636250	EXM213-215/4.100CH2	Not Available	Not Available	80X157VFMTXZ	10	213JM	6.625
1.5x1.5x7C	130635410	EXM143-145/4.075BH2	80X157AEMTXW	80X157AEMTXY	80X157AEMTXZ	7.5	143JM	6
1.5x1.5x9.5B	130637210	EXM254-256/4.300DH2	80X159JNMTXW	80X159JNMTXY	80X159JNMTXZ	30	254JM	9.5
1.5x1.5x9.5B	130637090	EXM254-256/4.250DH2	Not Available	Not Available	80X159JHJTXZ	25	254JM	9
1.5x1.5x9.5B	130636970	EXM254-256/4.200DH2	80X159GHMTXW	80X159GHMTXY	80X159GHMTXZ	20	254JM	8.5
1.5x1.5x9.5B	130636370	EXM213-215/4.150CH2	Not Available	Not Available	80X159GYGTXZ	15	213JM	7.75
2x2x7B	130636970	EXM254-256/4.200DH2	80X207CHMTXW	80X207CHMTXY	80X207CHMTXZ	20	254JM	7
2x2x7B	130636370	EXM213-215/4.150CH2	Not Available	Not Available	80X207VGMTXZ	15	213JM	6.625
2x2x7B	130636250	EXM213-215/4.100CH2	80X207AFMTXW	80X207AFMTXY	80X207AFMTXZ	10	213JM	6
2x2x7B	130635410	EXM143-145/4.075BH2	Not Available	Not Available	80X207NEMTXZ	7.5	143JM	5.25
2x2x9.5C	130637210	EXM254-256/4.300DH2	80X209GNMTXW	80X209GNMTXY	80X209GNMTXZ	30	254JM	8.5
2.5x2.5x7B	130636970	EXM254-256/4.200DH2	80X257CHMTXW	80X257CHMTXY	80X257CHMTXZ	20	254JM	7
2.5x2.5x7B	130636370	EXM213-215/4.150CH2	Not Available	Not Available	80X257VGMTXZ	15	213JM	6.625
2.5x2.5x7B	130636250	EXM213-215/4.100CH2	80X257AFMTXW	80X257AFMTXY	80X257AFMTXZ	10	213JM	6
2.5x2.5x7B	130635410	EXM143-145/4.075BH2	Not Available	Not Available	80X257NEMTXZ	7.5	143JM	5.25
2.5x2.5x9.5C	130637210	EXM254-256/4.300DH2	80X259ENMTXW	80X259ENMTXY	80X259ENMTXZ	30	254JM	8
3x3x7C	130637210	EXM254-256/4.300DH2	80X307CNMTXW	80X307CNMTXY	80X307CNMTXZ	30	254JM	7
3x3x7C	130637090	EXM254-256/4.250DH2	Not Available	Not Available	80X307CJMTXZ	25	254JM	7
3x3x7C	130636370	EXM213-215/4.150CH2	80X307QGMTXW	80X307QGMTXY	80X307QGMTXZ	15	213JM	5.5
3x3x9.5C	130637210	EXM254-256/4.300DH2	80X309DNMTXW	80X309DNMTXY	80X309DNMTXZ	30	254JM	7.25
3x3x11B	130637210	EXM254-256/4.300DH2	80X301ENMTXW	80X301ENMTXY	80X301ENMTXZ	30	254JM	8
4x4x7B	130637210	EXM254-256/4.300DH2	80X407BNMTXW	80X407BNMTXY	80X407BNMTXZ	30	254JM	6.5
4x4x7B	130637090	EXM254-256/4.250DH2	80X407AJMTXW	80X407AJMTXY	80X407AJMTXZ	25	254JM	6
5x5x7B	130637210	EXM254-256/4.300DH2	80X507QNMTXW	80X507QNMTXY	80X507QNMTXZ	30	254JM	5.5
6x6x7B	130637210	EXM254-256/4.300DH2	80X607QNMTXW	80X607QNMTXY	80X607QNMTXZ	30	254JM	5.5

**High Speed (800-4000 RPM) 3 Phase - 200-240V (230V Nominal Voltage)**

Pump Size	Motor Code	Motor Type	BUNA/C/SiC	EPR/C/WC	EPR/SiC/SiC	Motor HP	NEMA Frame	Impeller Trim (in.)
1.5x1.5x7C	130637691	EXM213-215/3.075CH2	80X157AEMSXW	80X157AEMSXY	80X157AEMSXZ	7.5	213JM	6
1.5x1.5x9.5B	130636971	EXM254-256/3.200DH2	80X159GHMSXW	80X159GHMSXY	80X159GHMSXZ	20	254JM	8.5
1.5x1.5x9.5B	130637771	EXM254-256/3.150DH2	Not Available	Not Available	80X159YGMSXZ	15	254JM	7.75
2x2x7B	130636971	EXM254-256/3.200DH2	80X207CHMSXW	80X207CHMSXY	80X207CHMSXZ	20	254JM	7
2x2x7B	130637771	EXM254-256/3.150DH2	Not Available	Not Available	80X207VGMSXZ	15	254JM	6.625
2x2x7B	130637691	EXM213-215/3.075CH2	Not Available	Not Available	80X207NEMSXZ	7.5	213JM	5.25
2x2x9.5C	130636971	EXM254-256/3.200DH2	80X209DHMSXW	80X209DHMSXY	80X209DHMSXZ	20	254JM	7.25
2.5x2.5x7B	130636971	EXM254-256/3.200DH2	80X257CHMSXW	80X257CHMSXY	80X257CHMSXZ	20	254JM	7
2.5x2.5x7B	130637771	EXM254-256/3.150DH2	Not Available	Not Available	80X257VGMSXZ	15	254JM	6.625
2.5x2.5x7B	130637691	EXM213-215/3.075CH2	Not Available	Not Available	80X257NEMSXZ	7.5	213JM	5.25
3x3x7C	130636971	EXM254-256/3.200DH2	80X307BHMSXW	80X307BHMSXY	80X307BHMSXZ	20	254JM	6.5
3x3x7C	130637771	EXM254-256/3.150DH2	80X307QGMSXW	80X307QGMSXY	80X307QGMSXZ	15	254JM	5.5
4x4x7B	130636971	EXM254-256/3.200DH2	80X407RHMSXW	80X407RHMSXY	80X407RHMSXZ	20	254JM	5.75
5x5x7B	130636971	EXM254-256/3.200DH2	80X507PHMSXW	80X507PHMSXY	80X507PHMSXZ	20	254JM	5

## Series e-80X Assembly Configurations

Low Speed (450-2000 RPM) 3 Phase - 380-480V (460V Nominal Voltage)

Pump Size	Motor Code	Motor Type	BUNA/C/SiC	EPR/C/WC	EPR/SiC/SiC	Motor HP	NEMA Frame	Impeller Trim (in.)
1.5x1.5x7C	130635810	EXM143-145/4.030BH4	80X157CBLTXW	80X157CBLTXY	80X157CBLTXZ	3	143JM	7
1.5x1.5x9.5B	130636610	EXM213-215/4.055CH4	80X159JDLTXW	80X159JDLTXY	80X159JDLTXZ	5.5	213JM	9.5
1.5x1.5x9.5B	130635810	EXM143-145/4.030BH4	80X159GBLTXW	80X159GBLTXY	80X159GBLTXZ	3	143JM	8.5
2x2x7B	130635810	EXM143-145/4.030BH4	80X207CBLTXW	80X207CBLTXY	80X207CBLTXZ	3	143JM	7
2x2x9.5C	130636730	EXM213-215/4.075CH4	80X209JELTXW	80X209JELTXY	80X209JELTXZ	7.5	213JM	9.5
2x2x9.5C	130635810	EXM143-145/4.030BH4	80X209EBLTXW	80X209EBLTXY	80X209EBLTXZ	3	143JM	8
2.5x2.5x7B	130635810	EXM143-145/4.030BH4	80X257CBLTXW	80X257CBLTXY	80X257CBLTXZ	3	143JM	7
2.5x2.5x9.5C	130636730	EXM213-215/4.075CH4	80X259JELTXW	80X259JELTXY	80X259JELTXZ	7.5	213JM	9.5
2.5x2.5x9.5C	130636610	EXM213-215/4.055CH4	80X259EDLTXW	80X259EDLTXY	80X259EDLTXZ	5.5	213JM	8
2.5x2.5x9.5C	130635810	EXM143-145/4.030BH4	Not Available	Not Available	80X259CBLTXZ	3	145JM	7
3x3x7C	130637730	EXM213-215/4.040CH4	80X307CCLTXW	80X307CCLTXY	80X307CCLTXZ	4	213JM	7
3x3x7C	130635810	EXM143-145/4.030BH4	Not Available	Not Available	80X307CBLTXZ	3	143JM	7
3x3x9.5C	130638390	EXM254-256/4.100DH4	80X309JFLTXW	80X309JFLTXY	80X309JFLTXZ	10	254JM	9.5
3x3x9.5C	130636730	EXM213-215/4.075CH4	80X309GELTXW	80X309GELTXY	80X309GELTXZ	7.5	213JM	8.5
3x3x9.5C	130636610	EXM213-215/4.055CH4	Not Available	Not Available	80X309YDLTXZ	5.5	213JM	7.75
3x3x11B	130637570	EXM254-256/4.150DH4	80X301LGLTXW	80X301LGLTXY	80X301LGLTXZ	15	254JM	11
3x3x11B	130638390	EXM254-256/4.100DH4	80X301KFLTXW	80X301KFLTXY	80X301KFLTXZ	10	254JM	10.5
3x3x11B	130636730	EXM213-215/4.075CH4	Not Available	Not Available	80X3019ELTXZ	7.5	213JM	9.625
4x4x7B	130636610	EXM213-215/4.055CH4	80X407CDLTXW	80X407CDLTXY	80X407CDLTXZ	5.5	213JM	7
4x4x7B	130635810	EXM143-145/4.030BH4	Not Available	Not Available	80X407ABLTXZ	3	145JM	6
4x4x9.5B	130637570	EXM254-256/4.150DH4	80X409JGLTXW	80X409JGLTXY	80X409JGLTXZ	15	254JM	9.5
4x4x9.5B	130638390	EXM254-256/4.100DH4	80X409GFLTXW	80X409GFLTXY	80X409GFLTXZ	10	254JM	8.5
4x4x9.5B	130636730	EXM213-215/4.075CH4	Not Available	Not Available	80X409YELTXZ	7.5	213JM	7.75
4x4x11	130637570	EXM254-256/4.150DH4	80X401KGLTXW	80X401KGLTXY	80X401KGLTXZ	15	254JM	10.5
4x4x11	130638390	EXM254-256/4.100DH4	Not Available	Not Available	80X401HFLTXZ	10	254JM	9
5x5x7B	130636730	EXM213-215/4.075CH4	80X507CELTXW	80X507CELTXY	80X507CELTXZ	7.5	213JM	7
5x5x7B	130636610	EXM213-215/4.055CH4	80X507ADLTXW	80X507ADLTXY	80X507ADLTXZ	5.5	213JM	6
5x5x7B	130635810	EXM143-145/4.030BH4	Not Available	Not Available	80X507QBLTXZ	3	145JM	5.5
5x5x9.5B	130637570	EXM254-256/4.150DH4	80X509HGLTXW	80X509HGLTXY	80X509HGLTXZ	15	254JM	9
5x5x9.5B	130638390	EXM254-256/4.100DH4	Not Available	Not Available	80X509YFLTXZ	10	254JM	7.75
6x6x7B	130637450	EXM254-256/4.100DH4	80X607CFLTXW	80X607CFLTXY	80X607CFLTXZ	10	254JM	7
6x6x7B	130636730	EXM213-215/4.075CH4	Not Available	Not Available	80X607MELTXZ	7.5	213JM	6.75
6x6x7B	130636610	EXM213-215/4.055CH4	Not Available	Not Available	80X607SDLTXZ	5.5	213JM	6.125
6x6x9.5B	130637570	EXM254-256/4.150DH4	80X601FGLTXW	80X601FGLTXY	80X601FGLTXZ	15	254JM	8.25
6x6x9.5B	130638390	EXM254-256/4.100DH4	Not Available	Not Available	80X601WFLTXZ	10	254JM	7.125

**Series e-80X  
Assembly Configurations**

Low Speed (450-2000 RPM) 3 Phase - 200-240V (230V Nominal Voltage)

Pump Size	Motor Code	Motor Type	BUNA/C/SiC	EPR/C/WC	EPR/SiC/SiC	Motor HP	NEMA Frame	Impeller Trim (in.)
1.5x1.5x7C	130635811	EXM143-145/3.030BH4	80X157CBLSXW	80X157CBLSXY	80X157CBLSXZ	3	143JM	7
1.5x1.5x9.5B	130636611	EXM213-215/3.055CH4	80X159JDLSXW	80X159JDLSXY	80X159JDLSXZ	5.5	213JM	9.5
1.5x1.5x9.5B	130635811	EXM143-145/3.030BH4	80X159GBLSXW	80X159GBLSXY	80X159GBLSXZ	3	143JM	8.5
2x2x7B	130635811	EXM143-145/3.030BH4	80X207CBLSXW	80X207CBLSXY	80X207CBLSXZ	3	143JM	7
2x2x9.5C	130636731	EXM213-215/3.075CH4	80X209JELSXW	80X209JELSXY	80X209JELSXZ	7.5	213JM	9.5
2x2x9.5C	130635811	EXM143-145/3.030BH4	80X209EBLSXW	80X209EBLSXY	80X209EBLSXZ	3	143JM	8
2.5x2.5x7B	130635811	EXM143-145/3.030BH4	80X257CBLSXW	80X257CBLSXY	80X257CBLSXZ	3	143JM	7
2.5x2.5x9.5C	130636731	EXM213-215/3.075CH4	80X259JELSXW	80X259JELSXY	80X259JELSXZ	7.5	213JM	9.5
2.5x2.5x9.5C	130636611	EXM213-215/3.055CH4	80X259EDLSXW	80X259EDLSXY	80X259EDLSXZ	5.5	213JM	8
2.5x2.5x9.5C	130635811	EXM143-145/3.030BH4	Not Available	Not Available	80X259CBLSXZ	3	145JM	7
3x3x7C	130637731	EXM213-215/3.040CH4	80X307CCLSXW	80X307CCLSXY	80X307CCLSXZ	4	213JM	7
3x3x7C	130635811	EXM143-145/3.030BH4	Not Available	Not Available	80X307CBLSXZ	3	143JM	7
3x3x9.5C	130638391	EXM254-256/3.100DH4	80X309JFLSXW	80X309JFLSXY	80X309JFLSXZ	10	254JM	9.5
3x3x9.5C	130636731	EXM213-215/3.075CH4	80X309GELSXW	80X309GELSXY	80X309GELSXZ	7.5	213JM	8.5
3x3x9.5C	130636611	EXM213-215/3.055CH4	Not Available	Not Available	80X309YDLSXZ	5.5	213JM	7.75
3x3x11B	130637571	EXM254-256/3.150DH4	80X301LGLSXW	80X301LGLSXY	80X301LGLSXZ	15	254JM	11
3x3x11B	130638391	EXM254-256/3.100DH4	80X301KFLSXW	80X301KFLSXY	80X301KFLSXZ	10	254JM	10.5
3x3x11B	130636731	EXM213-215/3.075CH4	Not Available	Not Available	80X3019ELSXZ	7.5	213JM	9.625
4x4x7B	130636611	EXM213-215/3.055CH4	80X407CDLSXW	80X407CDLSXY	80X407CDLSXZ	5.5	213JM	7
4x4x7B	130635811	EXM143-145/3.030BH4	Not Available	Not Available	80X407ABLSXZ	3	145JM	6
4x4x9.5B	130637571	EXM254-256/3.150DH4	80X409JGLSXW	80X409JGLSXY	80X409JGLSXZ	15	254JM	9.5
4x4x9.5B	130638391	EXM254-256/3.100DH4	80X409GFLSXW	80X409GFLSXY	80X409GFLSXZ	10	254JM	8.5
4x4x9.5B	130636731	EXM213-215/3.075CH4	Not Available	Not Available	80X409YELSXZ	7.5	213JM	7.75
4x4x11	130637571	EXM254-256/3.150DH4	80X401KGLSXW	80X401KGLSXY	80X401KGLSXZ	15	254JM	10.5
4x4x11	130638391	EXM254-256/3.100DH4	Not Available	Not Available	80X401HFLSXZ	10	254JM	9
5x5x7B	130636731	EXM213-215/3.075CH4	80X507CELSXW	80X507CELSXY	80X507CELSXZ	7.5	213JM	7
5x5x7B	130636611	EXM213-215/3.055CH4	80X507ADLSXW	80X507ADLSXY	80X507ADLSXZ	5.5	213JM	6
5x5x7B	130635811	EXM143-145/3.030BH4	Not Available	Not Available	80X507QBLSXZ	3	145JM	5.5
5x5x9.5B	130637571	EXM254-256/3.150DH4	80X509HGLSXW	80X509HGLSXY	80X509HGLSXZ	15	254JM	9
5x5x9.5B	130638391	EXM254-256/3.100DH4	Not Available	Not Available	80X509YFLSXZ	10	254JM	7.75
6x6x7B	130637451	EXM254-256/3.100DH4	80X607CFLSXW	80X607CFLSXY	80X607CFLSXZ	10	254JM	7
6x6x7B	130636731	EXM213-215/3.075CH4	Not Available	Not Available	80X607MELSXZ	7.5	213JM	6.75
6x6x7B	130636611	EXM213-215/3.055CH4	Not Available	Not Available	80X607SDLSXZ	5.5	213JM	6.125
6x6x9.5B	130637571	EXM254-256/3.150DH4	80X601FGLSXW	80X601FGLSXY	80X601FGLSXZ	15	254JM	8.25
6x6x9.5B	130638391	EXM254-256/3.100DH4	Not Available	Not Available	80X601WFLSXZ	10	254JM	7.125

## Series e-80X motor specifications document list<sup>1</sup>

Speed Tier	Motor Type	Voltage Range	Power (hp)	Motor Frame	Specification Document Number
High Speed	EXM56/4.040BH2	380-480V	4	56	XY-hyXeXM-SUB-520
	EXM143-145/4.040BH2		4	143-145	XY-hyXeXM-SUB-521
	EXM143-145/4.055BH2		5.5	143-145	XY-hyXeXM-SUB-522
	EXM143-145/4.075BH2		7.5	143-145	XY-hyXeXM-SUB-523
	EXM213-215/4.075CH2		7.5	213-215	XY-hyXeXM-SUB-524
	EXM213-215/4.100CH2		10	213-215	XY-hyXeXM-SUB-525
	EXM213-215/4.150CH2		15	213-215	XY-hyXeXM-SUB-526
	EXM254-256/4.150DH2		15	254-256	XY-hyXeXM-SUB-527
	EXM254-256/4.200DH2		20	254-256	XY-hyXeXM-SUB-528
	EXM254-256/4.250DH2		25	254-256	XY-hyXeXM-SUB-529
	EXM254-256/4.300DH2		30	254-256	XY-hyXeXM-SUB-530
	EXM56/3.040BH2		200-240V	4	56
	EXM143-145/3.040BH2	4		143-145	XY-hyXeXM-SUB-536
	EXM213-215/3.075CH2	7.5		213-215	XY-hyXeXM-SUB-537
	EXM254-256/3.150DH2	15		254-256	XY-hyXeXM-SUB-538
	EXM254-256/3.200DH2	20		254-256	XY-hyXeXM-SUB-539
Low Speed	EXM56/4.020BH4	380-480V	2	56	XY-hyXeXM-SUB-542
	EXM56/4.030BH4		3	56	XY-hyXeXM-SUB-543
	EXM143-145/4.020BH4		2	143-145	XY-hyXeXM-SUB-544
	EXM143-145/4.030BH4		3	143-145	XY-hyXeXM-SUB-545
	EXM213-215/4.040CH4		4	213-215	XY-hyXeXM-SUB-546
	EXM213-215/4.055CH4		5.5	213-215	XY-hyXeXM-SUB-547
	EXM213-215/4.075CH4		7.5	213-215	XY-hyXeXM-SUB-548
	EXM254-256/4.075DH4		7.5	254-256	XY-hyXeXM-SUB-549
	EXM254-256/4.100DH4		10	254-256	XY-hyXeXM-SUB-550
	EXM254-256/4.150DH4		15	254-256	XY-hyXeXM-SUB-551
	EXM56/3.020BH4	200-240V	2	56	XY-hyXeXM-SUB-552
	EXM56/3.030BH4		3	56	XY-hyXeXM-SUB-553
	EXM143-145/3.020BH4		2	143-145	XY-hyXeXM-SUB-554
	EXM143-145/3.030BH4		3	143-145	XY-hyXeXM-SUB-555
	EXM213-215/3.040CH4		4	213-215	XY-hyXeXM-SUB-556
	EXM213-215/3.055CH4		5.5	213-215	XY-hyXeXM-SUB-557
	EXM213-215/3.075CH4		7.5	213-215	XY-hyXeXM-SUB-558
	EXM254-256/3.075DH4		7.5	254-256	XY-hyXeXM-SUB-559
	EXM254-256/3.100DH4		10	254-256	XY-hyXeXM-SUB-560
	EXM254-256/3.150DH4		15	254-256	XY-hyXeXM-SUB-561

<sup>1</sup> The table above consists of all NEMA frame hydrovar X motor types. Not all motor types are used in the e-80X product line.

## Series e-80X Electrical data

\* Please note: Efficiency values shown are power-drive-system (PDS) efficiencies which include the combined losses from both the inverter and motor. The values shown correspond to the full load range of the hydrovar X motor. The hydrovar X motor may operate below the minimum rated speed at partial loading.

Table 1: 56 Frame, High Speed, 380-480V

Pn HP	MOTOR TYPE	NEMA FRAME	SPEED (RPM) min-1	INPUT CURRENT (I) 380-480V A	DATA RELATED TO 460V						
					In	POWER FACTOR cos (φ)	Tn lb.ft	*PDS EFFICIENCY η%			
					A			100	75	50	
4.0	EXM56/4.040BH2	56	3000	6.7-5.3	5.4	0.80	7.04	87.6	87.5	86.0	
			3600		5.3			5.87	88.0	87.4	85.4
			4000		5.3			5.28	88.1	87.1	84.9

Table 2: 56 Frame, High Speed, 200-240V

Pn HP	MOTOR TYPE	NEMA FRAME	SPEED (RPM) min-1	INPUT CURRENT (I) 200-240V A	DATA RELATED TO 230V						
					In	POWER FACTOR cos (φ)	Tn lb.ft	*PDS EFFICIENCY η%			
					A			100	75	50	
4.0	EXM56/3.040BH2	56	-	10.7-8.9	-	0.94	-	-	-	-	
			3600		9.2			5.87	87.2	87.1	85.9
			4000		9.1			5.28	88.0	87.8	86.4

Table 3: 143-145 Frame High Speed, 380-480V

Pn HP	MOTOR TYPE	NEMA FRAME	SPEED (RPM) min-1	INPUT CURRENT (I) 380-480V A	DATA RELATED TO 460V						
					In	POWER FACTOR cos (φ)	Tn lb.ft	*PDS EFFICIENCY η%			
					A			100	75	50	
4.0	EXM143- 145/4.040BH2	143-145	3000	6.7-5.3	5.4	0.80	7.04	87.6	87.5	86.0	
			3600		5.3			5.87	88.0	87.4	85.4
			4000		5.3			5.28	88.1	87.1	84.9
5.5	EXM143- 145/4.055BH2		3000	7.7-6.6	6.8	0.86	9.39	87.3	87.7	87.5	
			3600		6.6			7.83	89.1	88.8	87.3
			4000		6.5			7.04	89.1	88.5	86.8
7.5	EXM143- 145/4.075BH2		3000	10.2-8.4	8.6	0.89	12.91	89.9	89.9	89.2	
			3600		8.6			10.76	89.7	89.5	88.5
			4000		8.4			9.68	90.5	89.4	87.4

## Series e-80X Electrical data

Table 4: 143-145 Frame High Speed, 200-240V

Pn HP	MOTOR TYPE	NEMA FRAME	SPEED (RPM) min-1	INPUT CURRENT (I) 200-240V A	DATA RELATED TO 230V					
					In A	POWER FACTOR cos (φ)	Tn lb.ft	*PDS EFFICIENCY η%		
								100	75	50
4.0	EXM143- 145/3.040BH2	143-145	3000	10.7-8.9	-	0.94	-	-	-	-
			3600		9.2		5.87	87.2	87.1	85.9
			4000		9.1		5.28	88.0	87.8	86.4
5.5	EXM143- 145/3.055BH2		3000	Unavailable						
			3600	Unavailable						
			4000	Unavailable						
7.5	EXM143- 145/3.075BH2		3000	Unavailable						
			3600	Unavailable						
			4000	Unavailable						

Table 5: 213-215 Frame, High Speed, 380-480V

Pn HP	MOTOR TYPE	NEMA FRAME	SPEED (RPM) min-1	INPUT CURRENT (I) 380-480V A	DATA RELATED TO 460V					
					In A	POWER FACTOR cos (φ)	Tn lb.ft	*PDS EFFICIENCY η%		
								100	75	50
7.50	EXM213- 215/4.075CH2	213-215	3000	11.4-11.0	11.1	0.72	12.92	90.5	90.1	88.8
			3600		10.6		10.76	90.8	90.1	88.5
			4000		10.6		9.68	90.5	89.5	87.4
10.0	EXM213- 215/4.100CH2		3000	14.4-12.5	12.2	0.85	17.61	90.8	90.1	88.4
			3600		12.4		14.67	90.2	89.2	87.0
			4000		12.0		13.20	90.6	89.5	87.1
15.0	EXM213- 215/4.150CH2		3000	20.3-16.5	16.8	0.90	25.82	91.2	90.7	89.3
			3600		16.9		21.52	91.1	90.5	89.1
			4000		17.0		19.37	90.6	90.2	88.4

Table 6: 213-215 Frame, High Speed, 200-240V

Pn HP	MOTOR TYPE	NEMA FRAME	SPEED (RPM) min-1	INPUT CURRENT (I) 200-240V A	DATA RELATED TO 230V					
					In A	POWER FACTOR cos (φ)	Tn lb.ft	*PDS EFFICIENCY η%		
								100	75	50
7.50	EXM213- 215/3.075CH2	213-215	3000	18.9-16.2	16.7	0.94	12.92	89.6	89.3	88.2
			3600		16.3		10.76	89.9	89.2	87.6
			4000		16.6		9.68	88.6	87.6	85.1
10.0	EXM213- 215/3.100CH2		3000	Unavailable						
			3600	Unavailable						
			4000	Unavailable						
15.0	EXM213- 215/3.150CH2		3000	Unavailable						
			3600	Unavailable						
			4000	Unavailable						

## Series e-80X Electrical data

Table 7: 254-256 Frame, High Speed, 380-480V

Pn HP	MOTOR TYPE	NEMA FRAME	SPEED (RPM) min-1	INPUT CURRENT (I) 380-480V A	DATA RELATED TO 460V					
					In A	POWER FACTOR cos (φ)	Tn lb.ft	*PDS EFFICIENCY η%		
								100	75	50
15.00	EXM254- 256/4.150DH2	254-256	3000	24.5-22.8	21.7	0.72	25.82	91.7	91.2	90.2
			3600		20.9		21.52	92.0	91.2	89.9
			4000		20.5		19.37	91.5	90.6	88.8
20.0	EXM254- 256/4.200DH2		3000	30.2-27.1	24.5	0.76	35.22	91.5	91.2	90.1
			3600		27.0		29.35	92.1	91.4	90.1
			4000		26.8		26.41	91.8	91.1	89.6
25.0	EXM254- 256/4.250DH2		3000	33.5-28.6	29.4	0.87	43.44	91.7	91.4	90.7
			3600		28.9		36.19	92.1	91.5	90.4
			4000		28.8		32.58	92.0	91.4	90.2
30.0	EXM254- 256/4.300DH2		3000	38.9-32.4	33.5	0.90	51.65	92.1	91.7	90.7
			3600		33.3		43.04	92.5	91.8	90.6
			4000		32.7		38.83	92.4	91.6	90.2

Table 8: 254-256 Frame, High Speed, 200-240V

Pn HP	MOTOR TYPE	NEMA FRAME	SPEED (RPM) min-1	INPUT CURRENT (I) 200-240V A	DATA RELATED TO 230V						
					In A	POWER FACTOR cos (φ)	Tn lb.ft	*PDS EFFICIENCY η%			
								100	75	50	
15.00	EXM254- 256/3.150DH2	254-256	3000	38.4-34.1	35.4	0.90	25.82	90.3	90.3	89.4	
			3600		33.7		21.52	91.2	90.8	89.7	
			4000		32.5		19.37	91.3	90.6	89.3	
20.0	EXM254- 256/3.200DH2		-	50.0-44.1	-	0.92	-	-	-	-	
			3600		44.9		29.35	91.1	90.6	89.5	
			4000		44.4		26.41	90.3	89.4	87.5	
25.0	EXM254- 256/3.250DH2		3000	Unavailable							
			3600	Unavailable							
			4000	Unavailable							
30.0	EXM254- 256/3.300DH2		3000	Unavailable							
			3600	Unavailable							
			4000	Unavailable							

Table 9: 56 Frame, Low Speed, 380-480V

Pn HP	MOTOR TYPE	NEMA FRAME	SPEED (RPM) min-1	INPUT CURRENT (I) 380-480V A	DATA RELATED TO 460V					
					In A	POWER FACTOR cos (φ)	Tn lb.ft	*PDS EFFICIENCY η%		
								100	75	50
2.0	EXM56/4.020BH4	56	1500	4.0-3.8	3.70	0.57	7.04	82.2	83.2	83.0
			1800		3.90		5.87	85.1	85.9	85.6
			2000		3.50		5.28	86.7	86.4	85.3
3.0	EXM56/4.030BH4		1500	5.0-4.6	4.70	0.69	10.33	85.6	85.8	84.9
			1800		4.60		8.61	88.0	87.6	86.5
			2000		4.50		7.74	89.0	88.6	87.3

## Series e-80X Electrical data

Table 10: 56 Frame, Low Speed, 200-240V

Pn HP	MOTOR TYPE	NEMA FRAME	SPEED (RPM) min-1	INPUT CURRENT (I) 200-240V A	DATA RELATED TO 230V						
					In A	POWER FACTOR cos (φ)	Tn lb.ft	*PDS EFFICIENCY η%			
								100	75	50	
2.0	EXM56/3.020BH4	56	1500	5.7-4.9	5.1	0.89	7.04	83.2	83.8	83.5	
			1800		4.9			5.87	85.7	85.9	85.3
			2000		4.9			5.28	86.5	85.7	83.6
3.0	EXM56/3.030BH4		1500	7.9-6.7	7.00	0.93	10.33	86.0	86.3	86.2	
			1800		6.80			8.63	87.9	87.7	86.8
			2000		6.70			7.74	88.9	88.9	87.9

Table 11: 143-145 Frame, Low Speed, 380-480V

Pn HP	MOTOR TYPE	NEMA FRAME	SPEED (RPM) min-1	INPUT CURRENT (I) 380-480V A	DATA RELATED TO 460V						
					In A	POWER FACTOR cos (φ)	Tn lb.ft	*PDS EFFICIENCY η%			
								100	75	50	
2.0	EXM143- 145/4.020BH4	143-145	1500	4.0-3.8	3.70	0.57	7.04	82.2	83.2	83.0	
			1800		3.90			5.87	85.1	85.9	85.6
			2000		3.50			5.28	86.7	86.4	85.3
3.0	EXM143- 145/4.030BH4		1500	5.0-4.6	4.70	0.69	10.33	85.6	85.8	84.9	
			1800		4.60			8.61	88.0	87.6	86.5
			2000		4.50			7.74	89.0	88.6	87.3

Table 12: 143-145 Frame, Low Speed, 200-240V

Pn HP	MOTOR TYPE	NEMA FRAME	SPEED (RPM) min-1	INPUT CURRENT (I) 200-240V A	DATA RELATED TO 230V						
					In A	POWER FACTOR cos (φ)	Tn lb.ft	*PDS EFFICIENCY η%			
								100	75	50	
2.0	EXM143- 145/3.020BH4	143-145	1500	5.7-4.9	5.1	0.89	7.04	83.2	83.8	83.5	
			1800		4.9			5.87	85.7	85.9	85.3
			2000		4.9			5.28	86.5	85.7	83.6
3.0	EXM143- 145/3.030BH4		1500	7.9-6.7	7.00	0.93	10.33	86.0	86.3	86.2	
			1800		6.80			8.63	87.9	87.7	86.8
			2000		6.70			7.74	88.9	88.9	87.9

Table 13: 213-215 Frame, Low Speed, 380-480V

Pn HP	MOTOR TYPE	NEMA FRAME	SPEED (RPM) min-1	INPUT CURRENT (I) 380-480V A	DATA RELATED TO 460V						
					In A	POWER FACTOR cos (φ)	Tn lb.ft	*PDS EFFICIENCY η%			
								100	75	50	
4.0	EXM213- 215/4.040CH4	213-215	1500	7.9-7	7.2	0.62	14.09	86.3	86.6	85.7	
			1800		6.9			11.73	88.1	87.9	86.8
			2000		7			10.55	88.5	88.2	87.1
5.5	EXM213- 215/4.055CH4		1500	9.2-8.5	8.9	0.66	18.78	89.4	89.4	88.8	
			1800		8.4			15.65	91.2	91.1	90.4
			2000		8.3			14.09	91.6	91.5	90.8
7.5	EXM213- 215/4.075CH4	1500	11.2-10.2	10.3	0.75	25.82	90.7	90.8	90.4		
		1800		10.1			21.52	91.6	91.8	90.6	
		2000		10.1			19.37	91.6	91.3	90.5	

## Series e-80X Electrical data

Table 14: 213-215 Frame, Low Speed, 200-240V

Pn HP	MOTOR TYPE	NEMA FRAME	SPEED (RPM) min-1	INPUT CURRENT (I) 200-240V A	DATA RELATED TO 230V						
					In	POWER FACTOR cos (φ)	Tn lb.ft	*PDS EFFICIENCY η%			
					A			100	75	50	
4.00	EXM213- 215/3.040CH4	213-215	1500	11.0-9.8	9.9	0.87	14.09	87.2	87.4	87.1	
			1800		9.8			11.73	88.3	88.3	87.7
			2000		9.8			10.55	88.4	88.7	87.7
5.5	EXM213- 215/3.055CH4		1500	14.0-12.3	12.5	0.92	18.81	88.4	88.8	88.7	
			1800		12.2			15.64	89.9	89.8	89.3
			2000		12.1			14.09	90.2	90.4	89.6
7.5	EXM213- 215/3.075CH4		1500	21.6-20.4	16.6	0.93	25.82	89.4	89.7	89.5	
			1800		16.5			21.52	90.2	90.5	90.2
			2000		16.6			19.37	90.1	90.4	90.1

Table 15: 254-256 Frame, Low Speed, 380-480V

Pn HP	MOTOR TYPE	NEMA FRAME	SPEED (RPM) min-1	INPUT CURRENT (I) 380-480V A	DATA RELATED TO 460V						
					In	POWER FACTOR cos (φ)	Tn lb.ft	*PDS EFFICIENCY η%			
					A			100	75	50	
7.50	EXM254- 256/4.075DH4	254-256	1500	15.3-13.6	14.1	0.55	25.82	88.6	88.6	87.9	
			1800		13.8			21.52	90.9	90.7	89.8
			2000		14.3			19.37	91.0	91.1	90.4
10.0	EXM254- 256/4.100DH4		1500	18.7-17.4	17.8	0.60	35.22	89.6	89.9	89.7	
			1800		17.3			29.35	91.0	90.8	89.9
			2000		17.2			26.41	91.3	91.2	90.1
15.0	EXM254- 256/4.150DH4		1500	24.5-22.8	22.9	0.66	51.65	91.1	91.2	90.7	
			1800		22.7			43.04	92.0	91.7	90.8
			2000		22.2			38.74	92.6	92.3	91.4

Table 16: 254-256 Frame, Low Speed, 200-240V

Pn HP	MOTOR TYPE	NEMA FRAME	SPEED (RPM) min-1	INPUT CURRENT (I) 200-240V A	DATA RELATED TO 230V						
					In	POWER FACTOR cos (φ)	Tn lb.ft	*PDS EFFICIENCY η%			
					A			100	75	50	
7.50	EXM254- 256/3.075DH4	254-256	1500	20.5-18.8	19.2	0.83	25.81	88.0	88.4	88.2	
			1800		18.6			21.54	88.9	88.6	87.6
			2000		18			19.40	89.8	89.6	88.8
10.0	EXM254- 256/3.100DH4		1500	27.5-24.8	25.4	0.88	35.22	88.9	89.3	89.1	
			1800		23.5			29.35	90.7	90.7	90.3
			2000		23.3			26.41	91.2	91.2	90.6
15.0	EXM254- 256/3.150DH4		1500	39.0-34.5	35.6	0.9	51.65	89.6	90.1	90.0	
			1800		33.6			43.05	91.1	91.0	90.6
			2000		32.9			38.74	91.5	91.2	90.5

# Terminal block hydrovar X

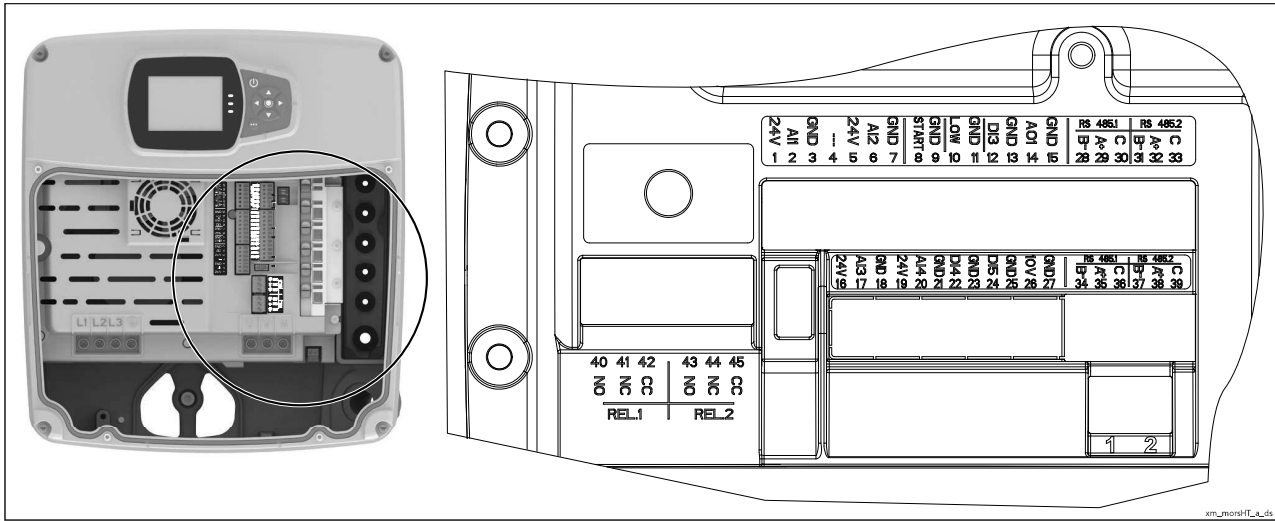

REF.	ITEM	DESCRIPTION	DEFAULT
1		Power supply +24 VDC, max. 60mA (total, terminals 1 + 5)	
2	Analog Input 1	Configurable Analog Input 1	Pressure Sensor 1
3		Electronic GND	
4	Not used	Internal use - Do not connect	
5		Power supply +24 VDC, max. 60mA (total, terminals 1 + 5)	
6	Analog Input 2	Configurable Analog Input 2	Not used
7		Electronic GND	
8	External Start/Stop	Start/Stop digital input, +24 VDC internal pull-up, 6mA contact current	-
9		Electronic GND	
10	External Lack of Water	Low water digital input, +24 VDC internal pull-up, 6mA contact current	-
11		Electronic GND	
12	Digital Input 3	Configurable Digital Input 3, +24 VDC internal pull-up, 6mA contact current	Solo Run
13		Electronic GND	
14	Analog Output	Configurable Analog Output	Motor Speed
15		Electronic GND	
16		Power supply +24 VDC, max. 60mA (total, terminals 16 and 19)	
17	Analog Input 3	Configurable Analog Input 3	Not used
18		Electronic GND	
19		Power supply +24 VDC, max. 60mA (total, terminals 16 and 19)	
20	Analog Input 4	Configurable Analog Input 4	Not used
21		Electronic GND	
22	Digital Input 4	Configurable Digital Input 4, +24 VDC internal pull-up, 6mA contact current	Not used
23		Electronic GND	
24	Digital Input 5	Configurable Digital Input 5, +24 VDC internal pull-up, 6mA contact current	Not used
25		Electronic GND	
26	10 VDC supply	Power supply +10 VDC, max. 3mA	-
27		Electronic GND	
28		RS485 port 1: RS485-1B N (-)	
29	Communication bus 1	RS485 port 1: RS485-1A P (+)	Multipump
30		RS485 port 1: RS485-COM	
31		RS485 port 2: RS485-2B N (-)	
32	Communication bus 2	RS485 port 2: RS485-2A P (+)	Modbus
33		RS485 port 2: RS485-COM	
34		RS485 port 1: RS485-1B N (-)	
35	Communication bus 1	RS485 port 1: RS485-1A P (+)	Multipump
36		RS485 port 1: RS485-COM	
37		RS485 port 2: RS485-2B N (-)	
38	Communication bus 2	RS485 port 2: RS485-2A P (+)	Modbus
39		RS485 port 2: RS485-COM	
40		Configurable relay 1: Normally Open	
41	Relay 1	Configurable relay 1: Normally Closed	Running
42		Configurable relay 1: Common Contact	
43		Configurable relay 2: Normally Open	
44	Relay 2	Configurable relay 2: Normally Closed	Error
45		Configurable relay 2: Common Contact	

## How to read smart pump Series curves

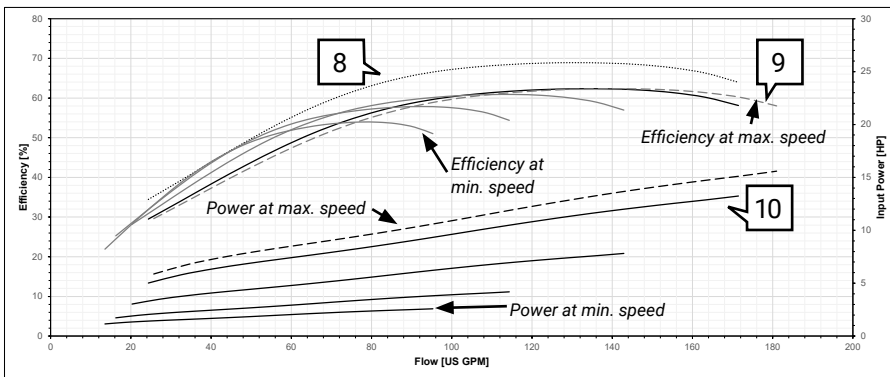
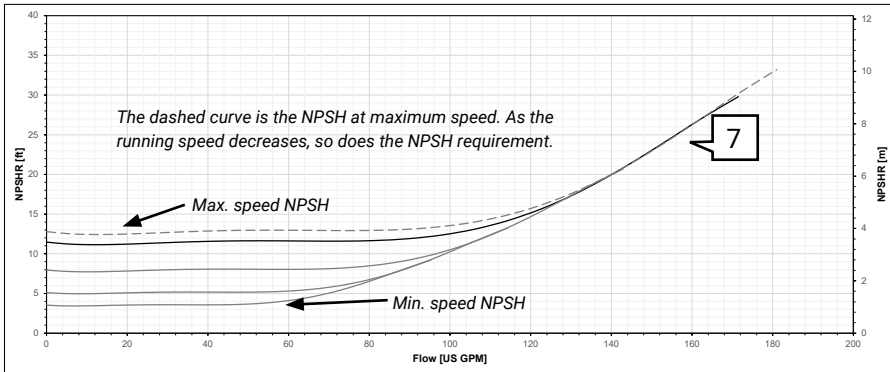
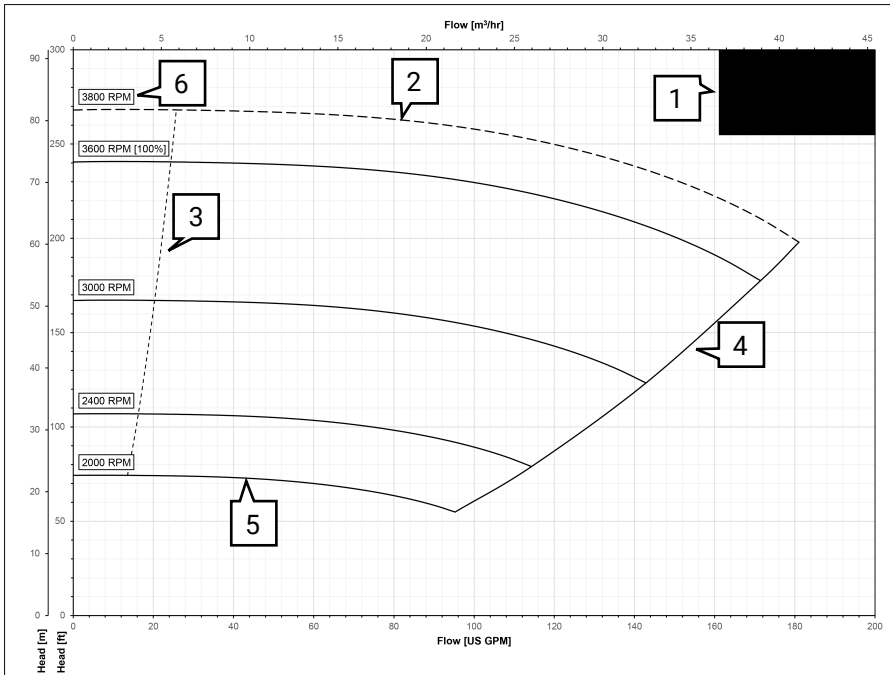

1. **Model Information:** pump model and motor information.
2. **Maximum Speed Curve:** the maximum operating speed of the pump. Any speed above the nominal speed rating (i.e. 1800 RPM or 3600 RPM) is indicated by a dashed line.
3. **Minimum Continuous Stable Flow:** the recommended minimum flow rate of the pump.
4. **Maximum Flow Curve:** the recommended maximum flow rate of the pump.
5. **Minimum Speed Curve:** the minimum operating speed of the pump for continuous operation.
6. **Speed Tags:** indicate the motor speed of a given performance curve. The [100%] modifier indicates the default maximum speed setting of the motor.
7. **NPSH Curve:** the net positive suction head required of the pump. The dashed NPSH curve corresponds to the maximum speed condition. The solid black NPSH curve represents the NPSH operating at the [100%] speed. Subsequent NPSH curves represent NPSH required by speed in decreasing order.
8. **Pump Efficiency Curve:** the standalone efficiency of the pump operating at the [100%] speed condition.
9. **Efficiency Overall:** the overall efficiency (wire-to-water efficiency) of the pump and motor per speed. *Note: efficiency curves for each speed are shown in descending order where lower speeds result in lower efficiency.*
10. **Input Power:** the input power required to drive the motor by speed.

# Series e-80X Performance Curves for High Speed Models - 460V

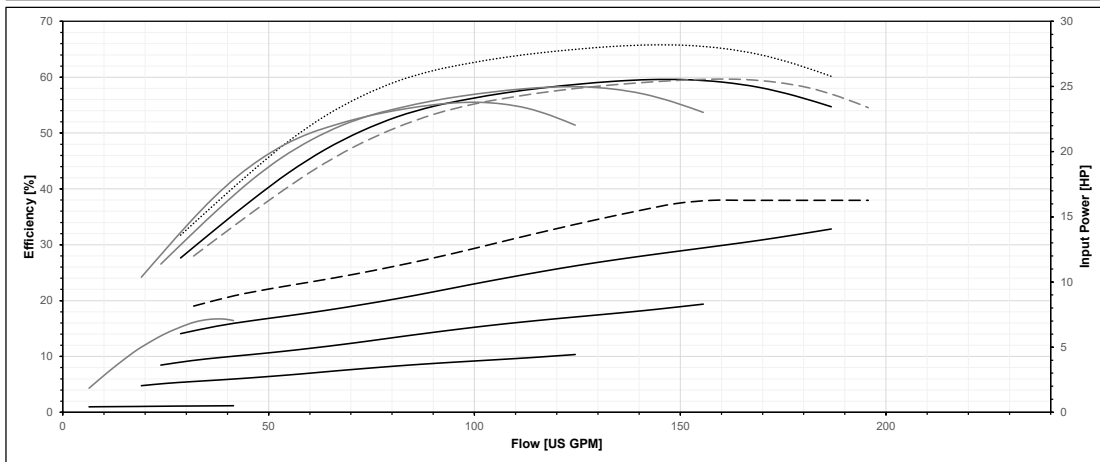
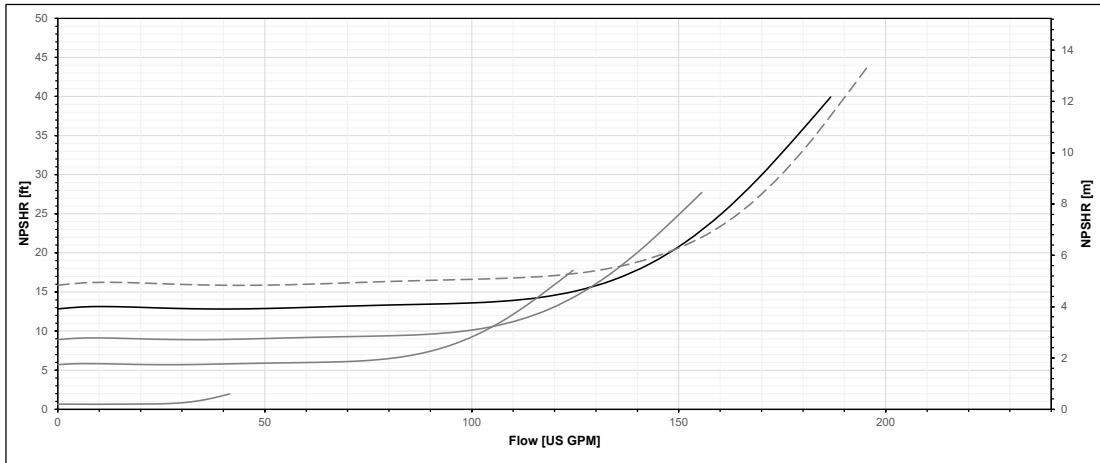
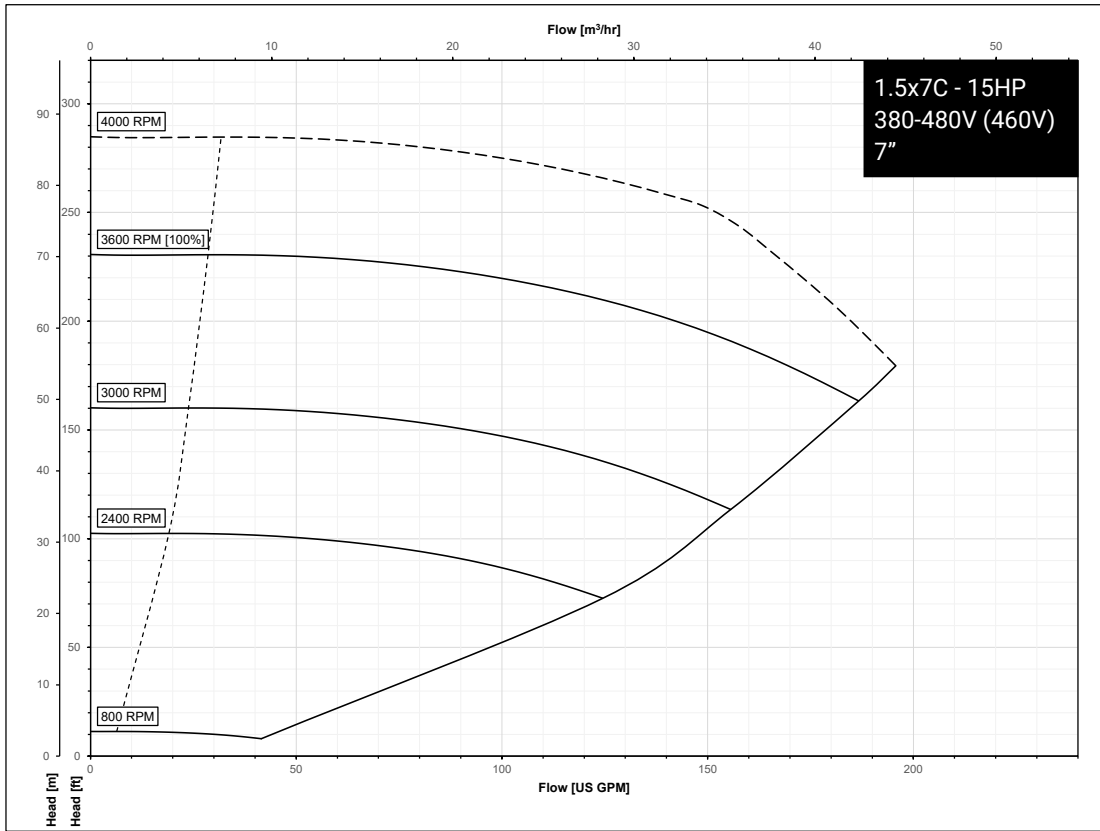

# Series e-80X Performance Curves for High Speed Models - 460V

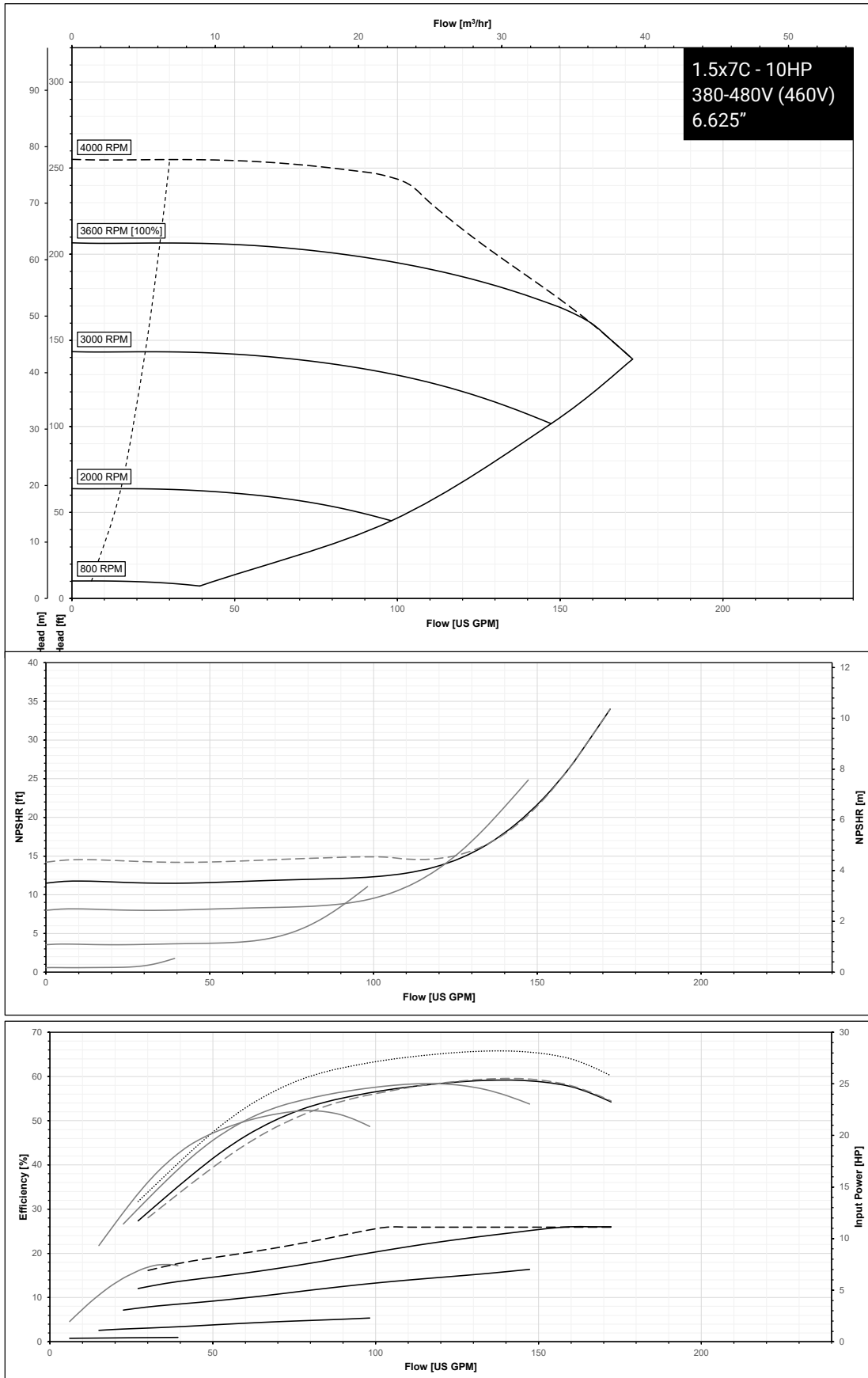

# Series e-80X Performance Curves for High Speed Models - 460V

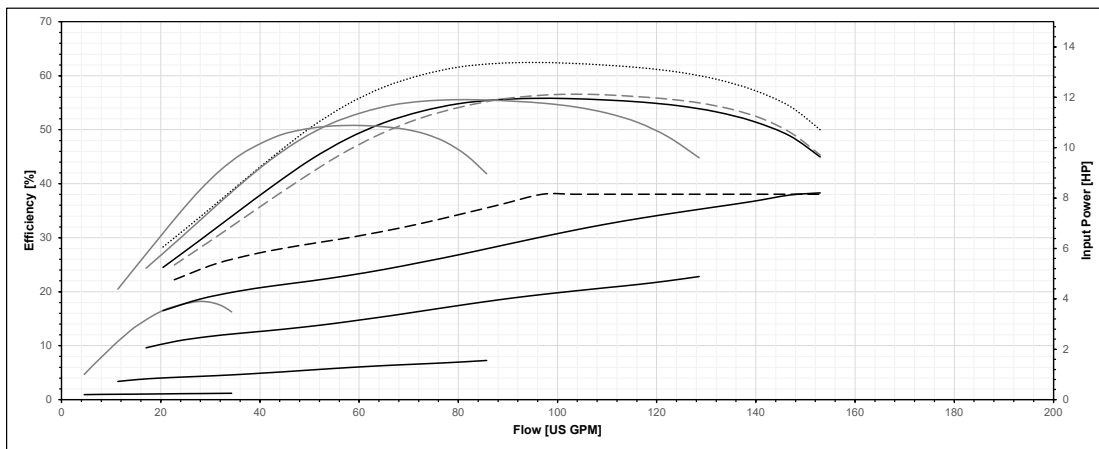
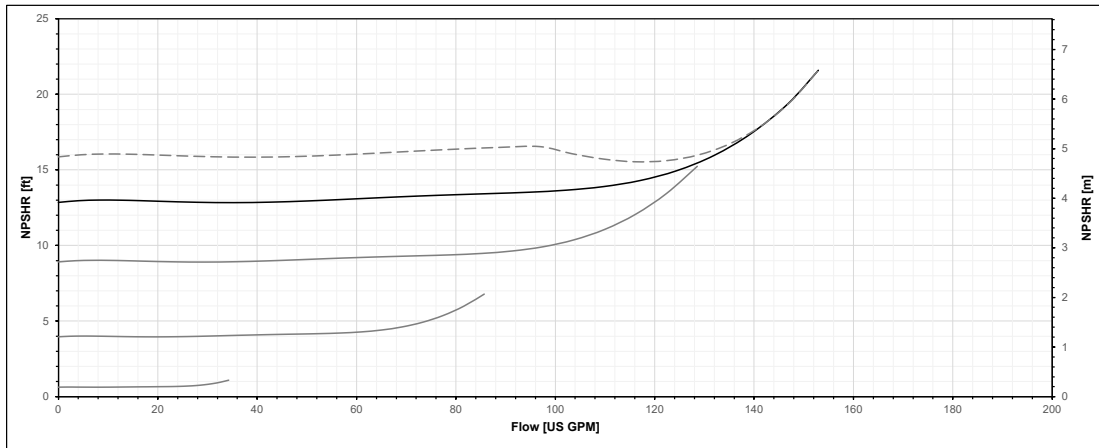
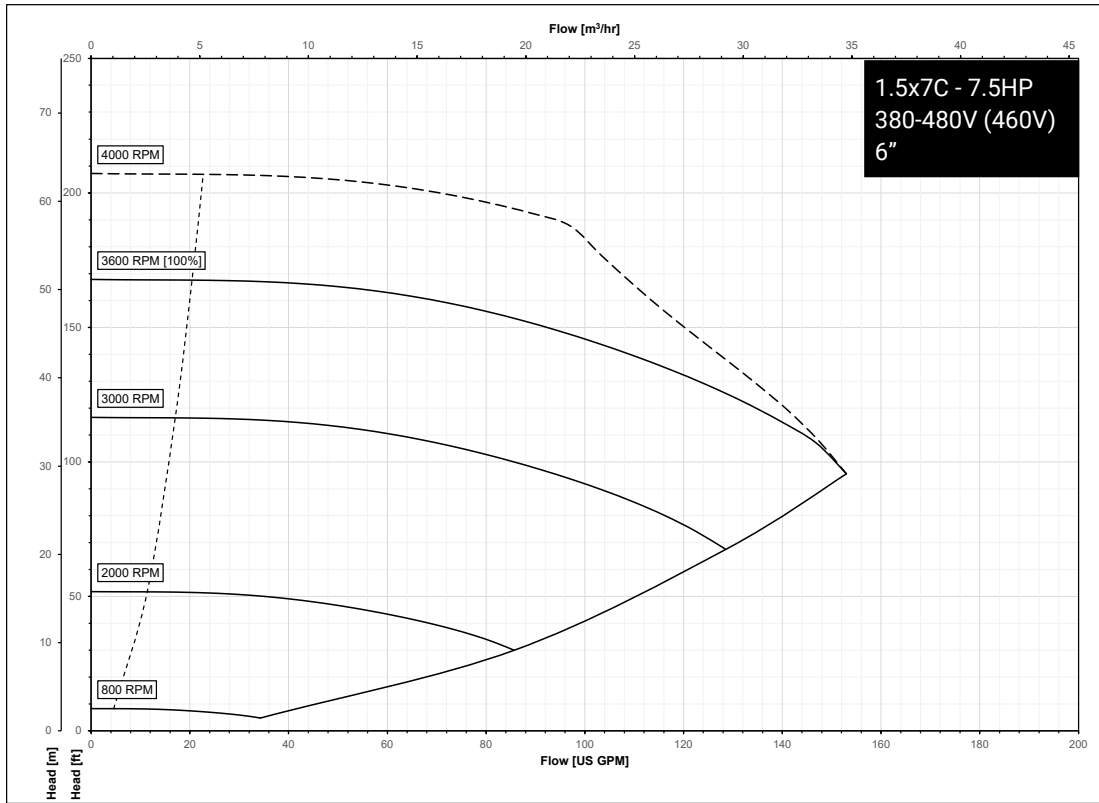

# Series e-80X Performance Curves for High Speed Models - 460V

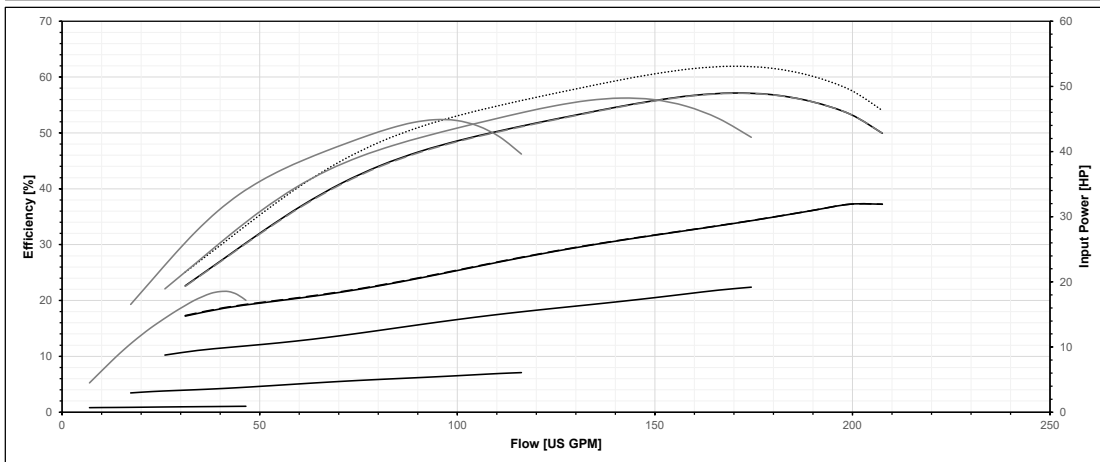
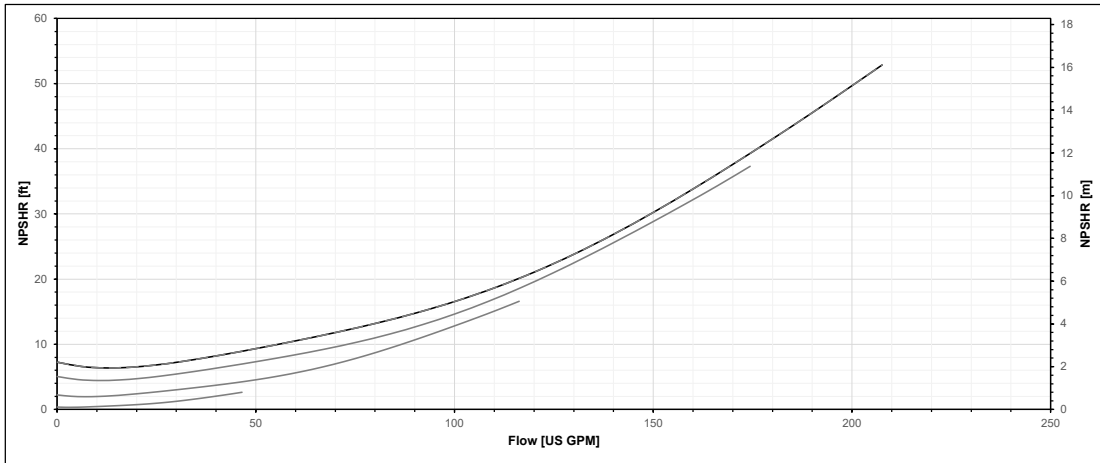
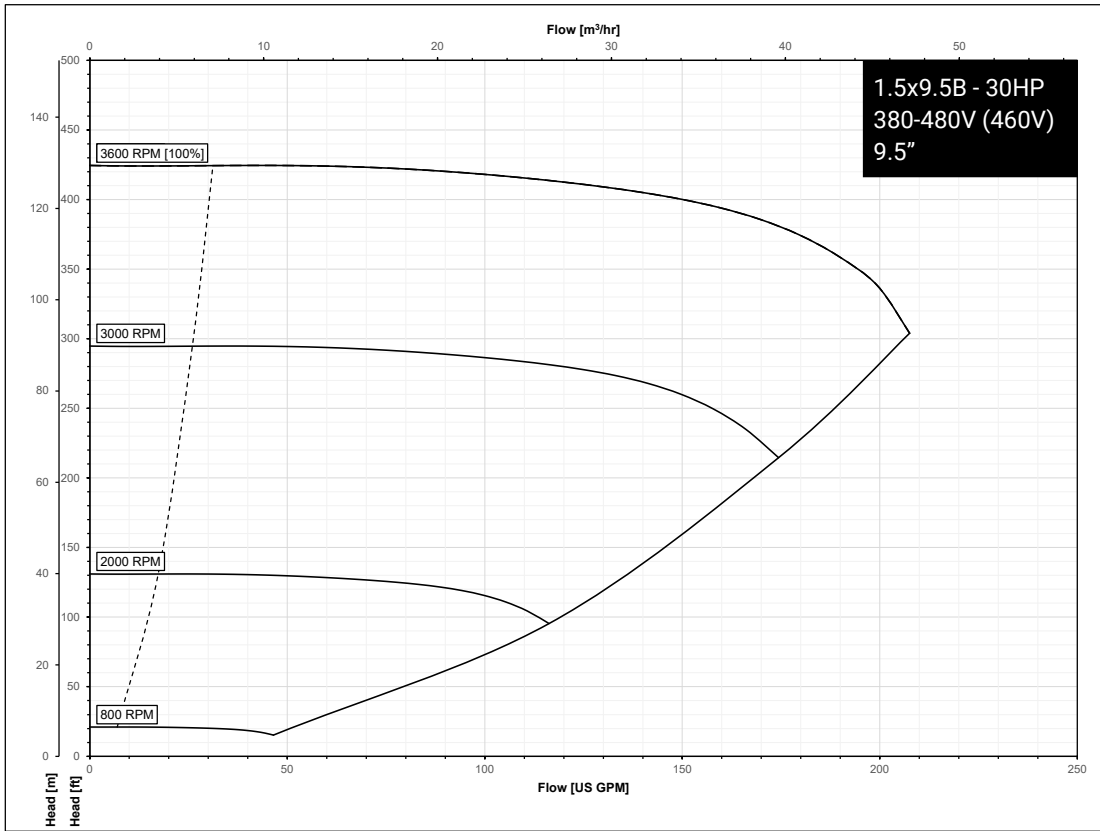

# Series e-80X Performance Curves for High Speed Models - 460V

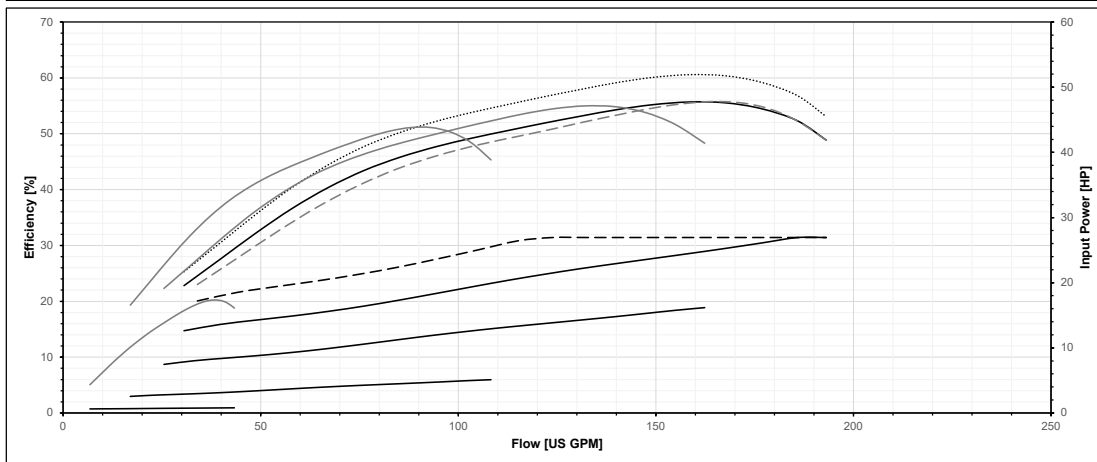
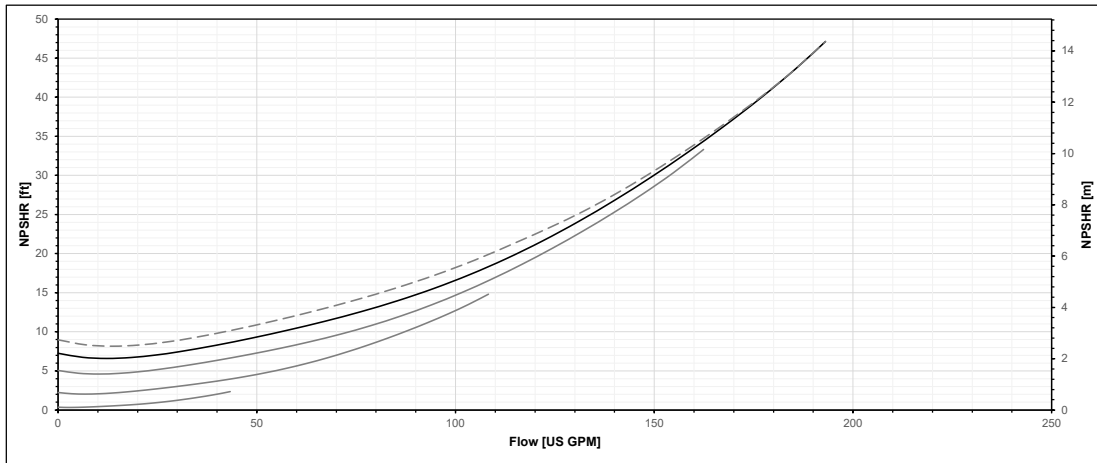
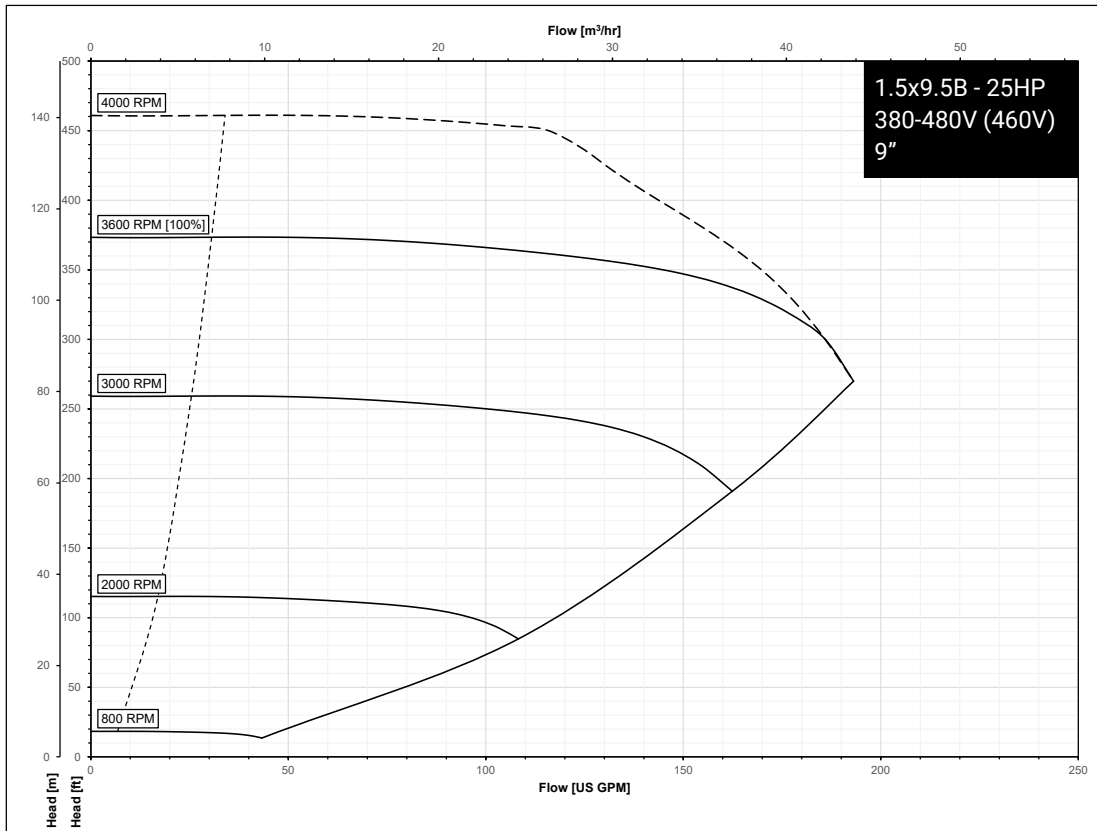

# Series e-80X Performance Curves for High Speed Models - 460V

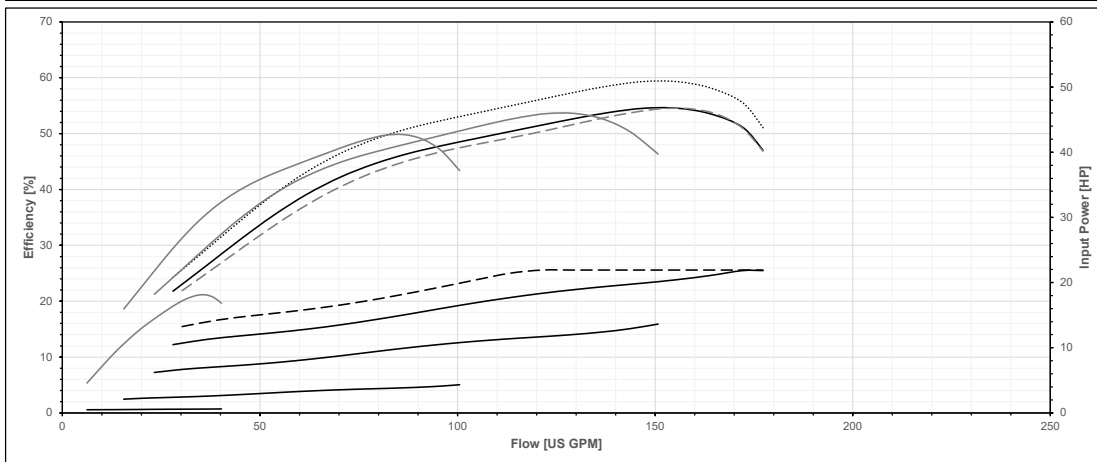
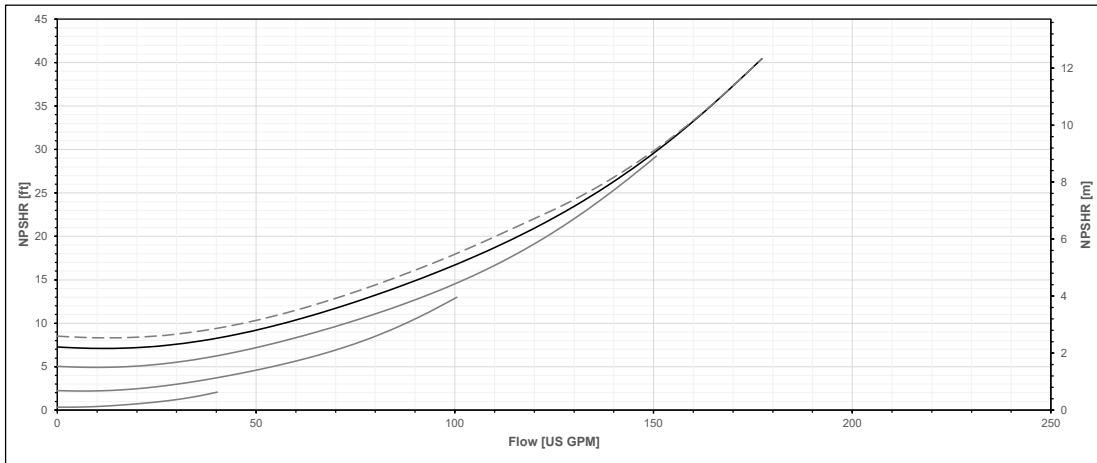
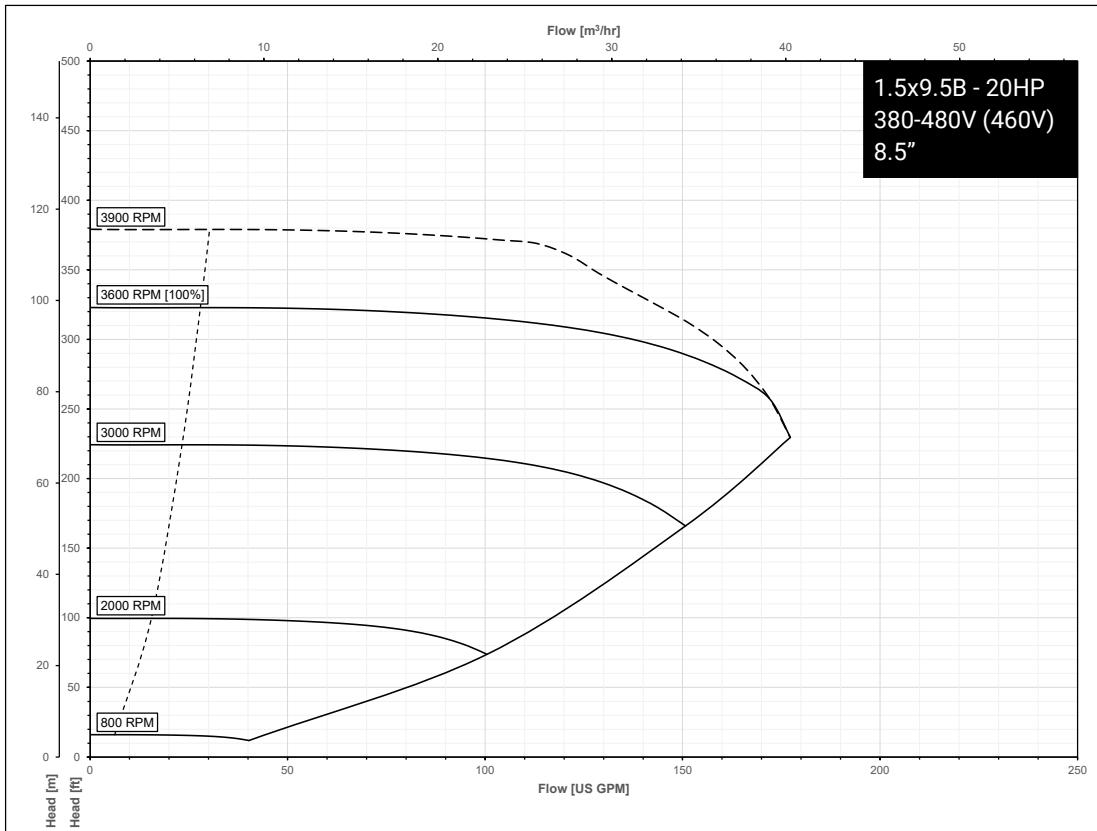

# Series e-80X Performance Curves for High Speed Models - 460V

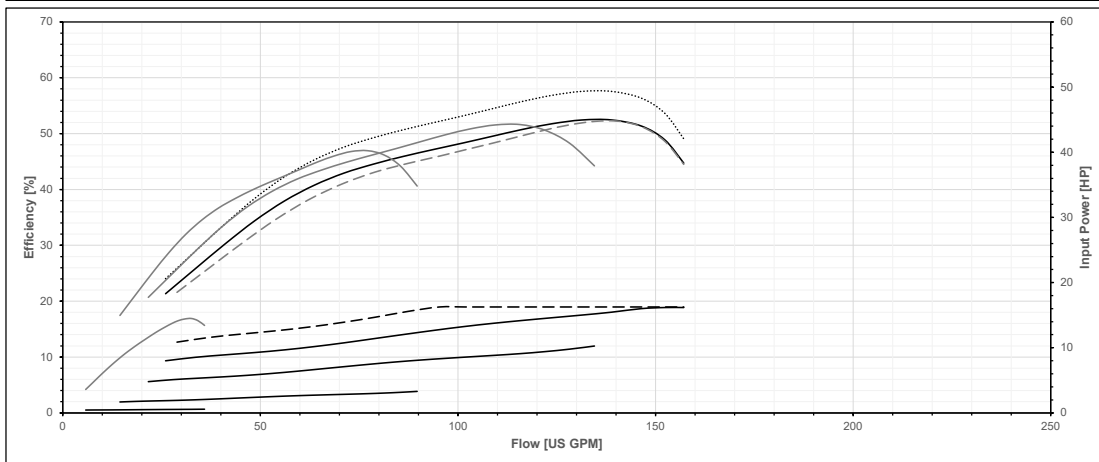
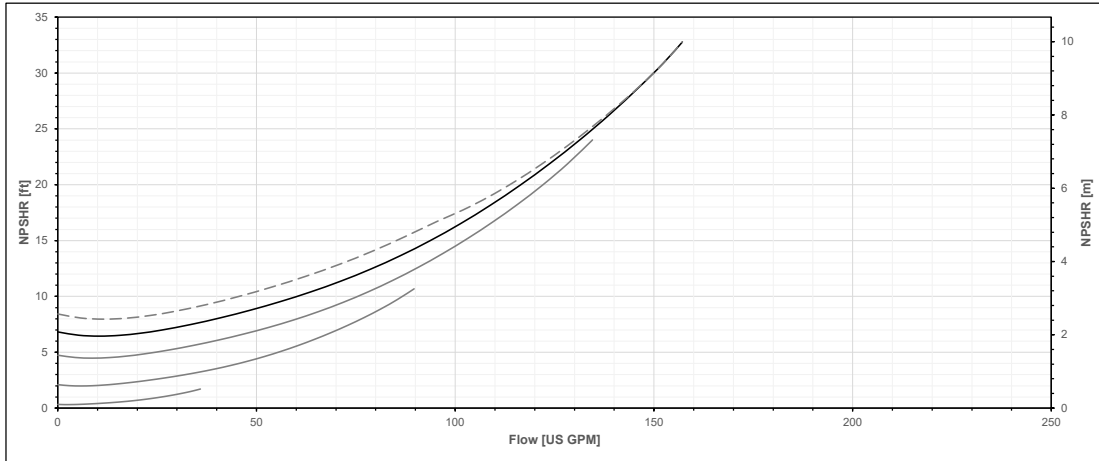
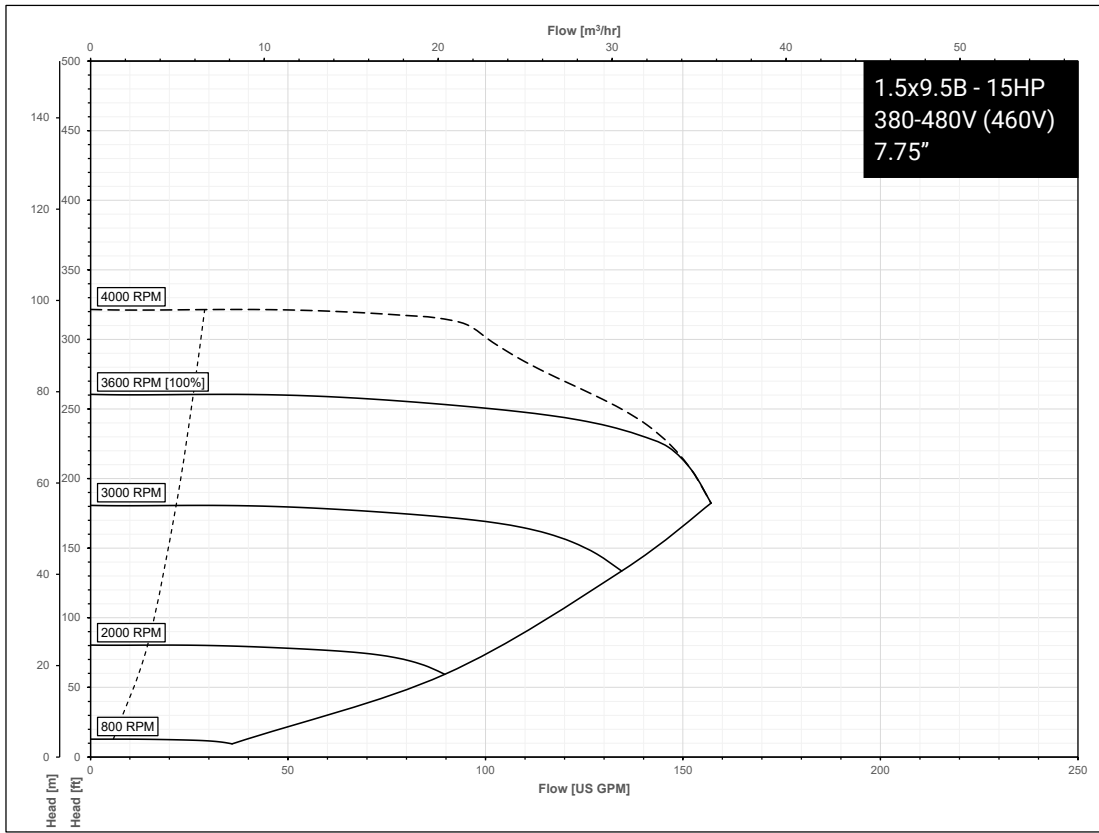

# Series e-80X Performance Curves for High Speed Models - 460V

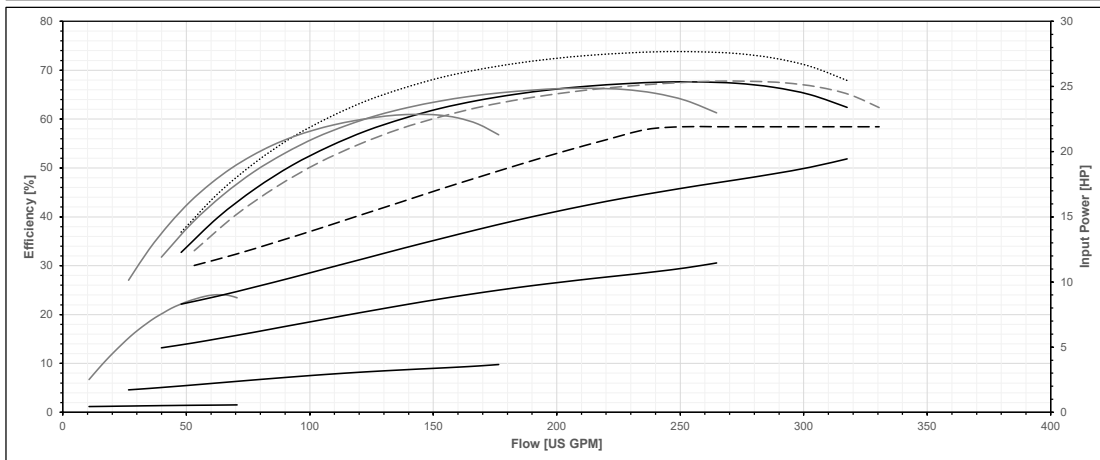
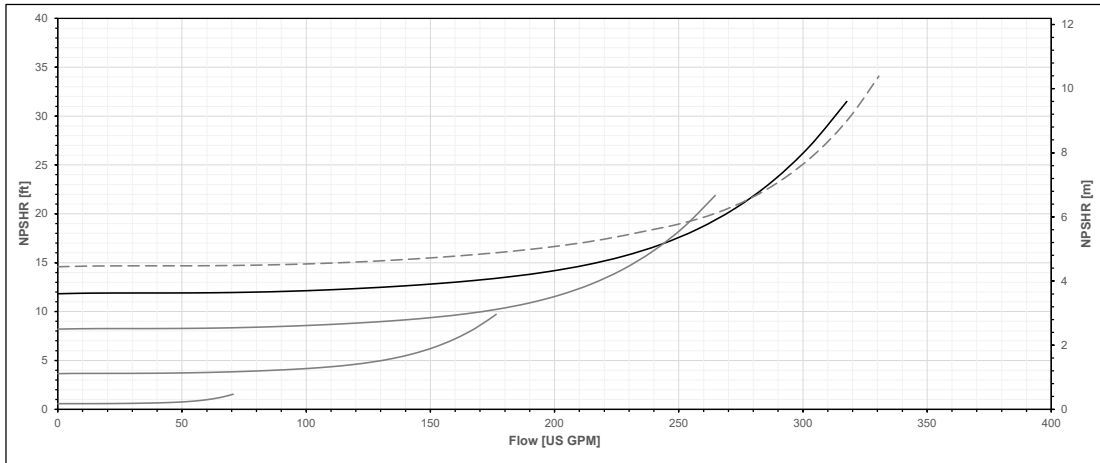
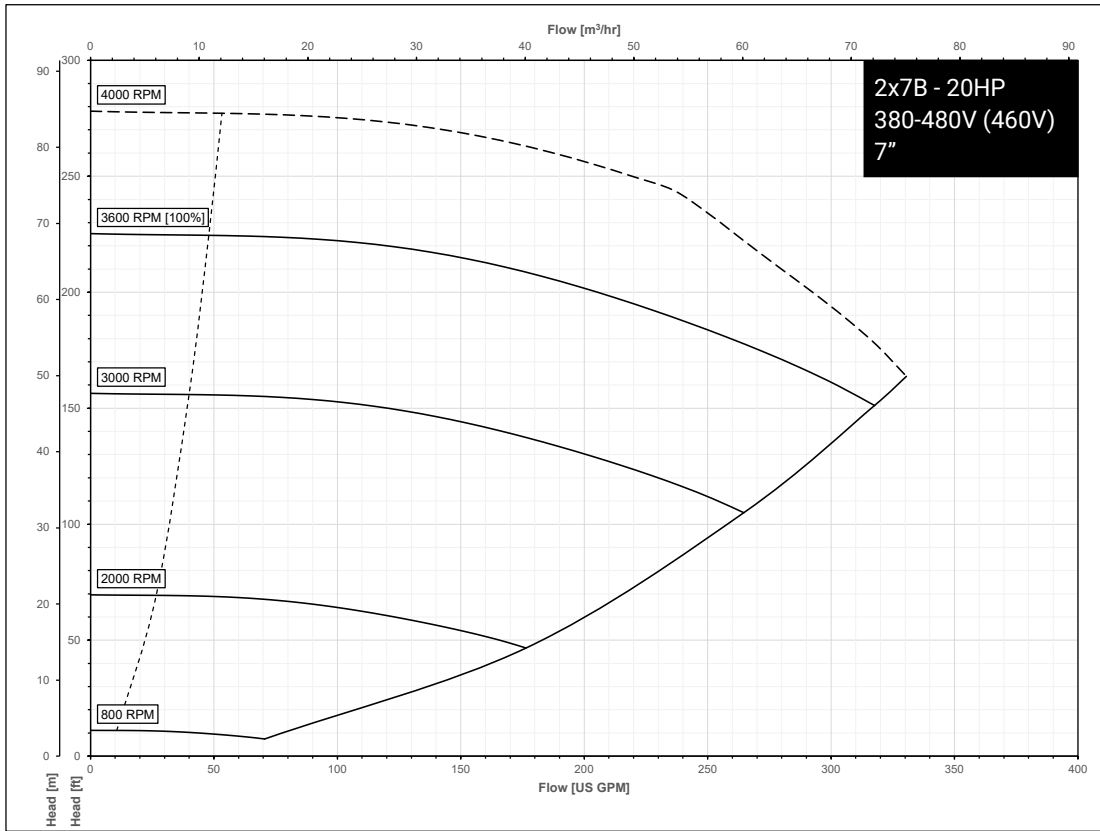

# Series e-80X Performance Curves for High Speed Models - 460V

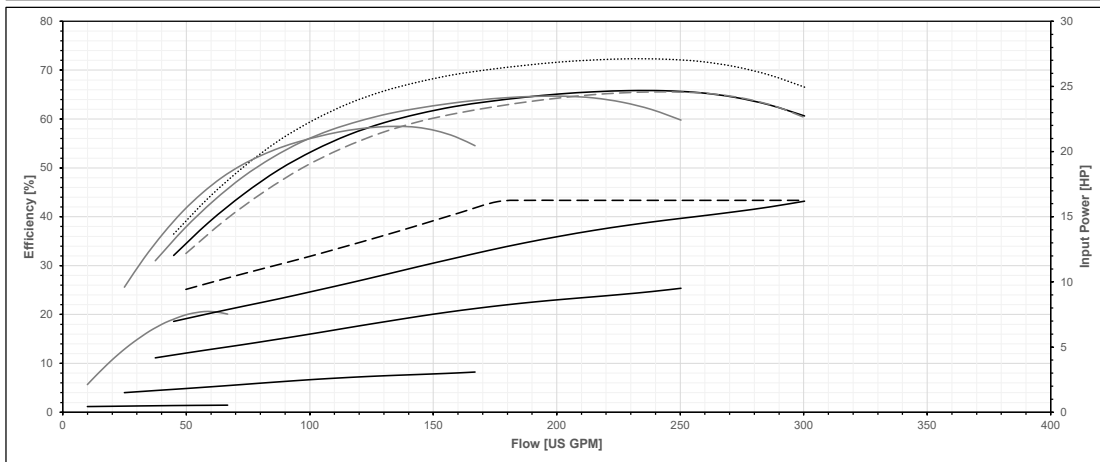
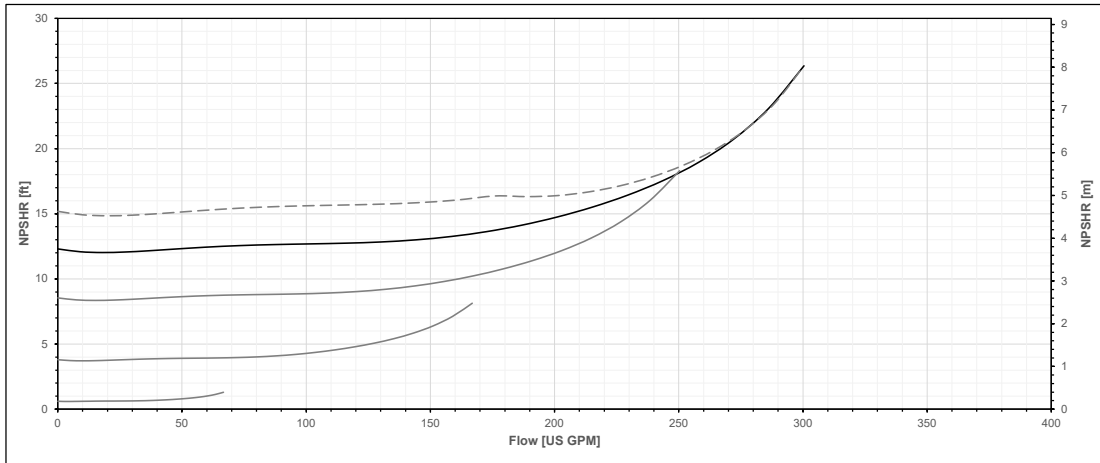
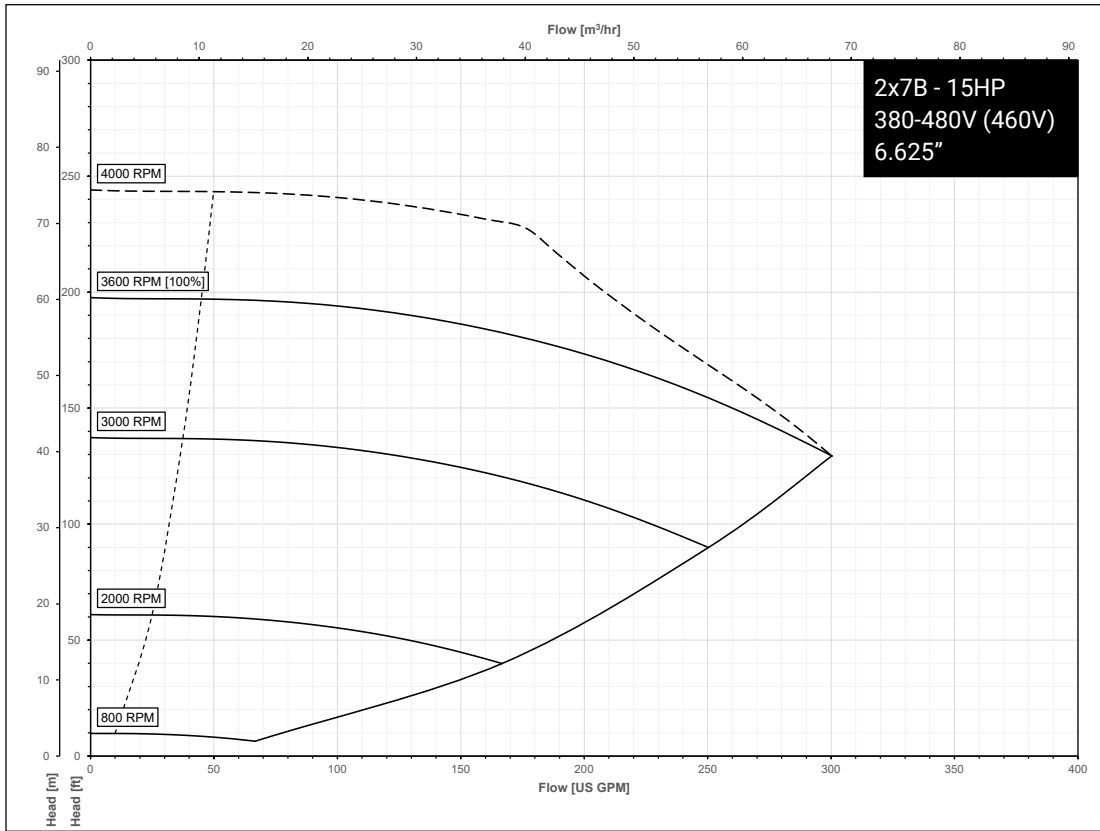

# Series e-80X Performance Curves for High Speed Models - 460V

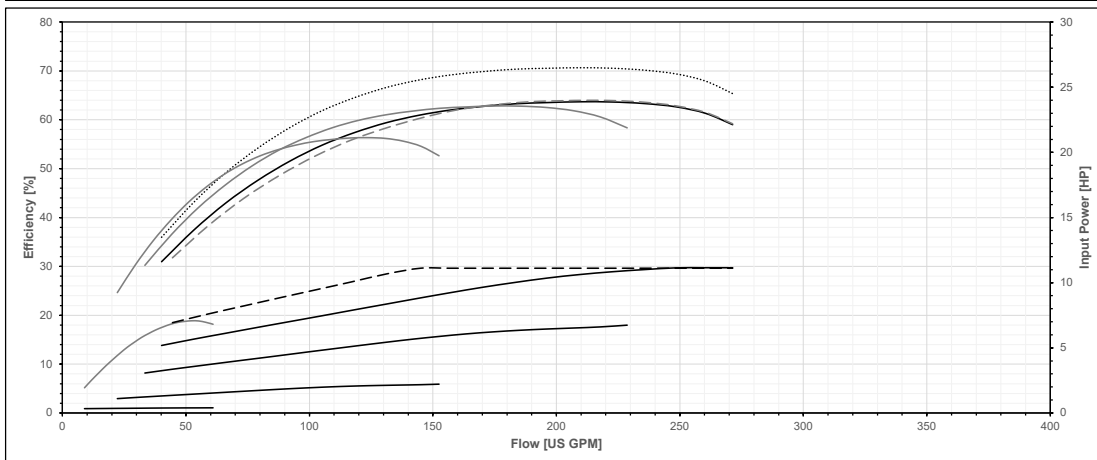
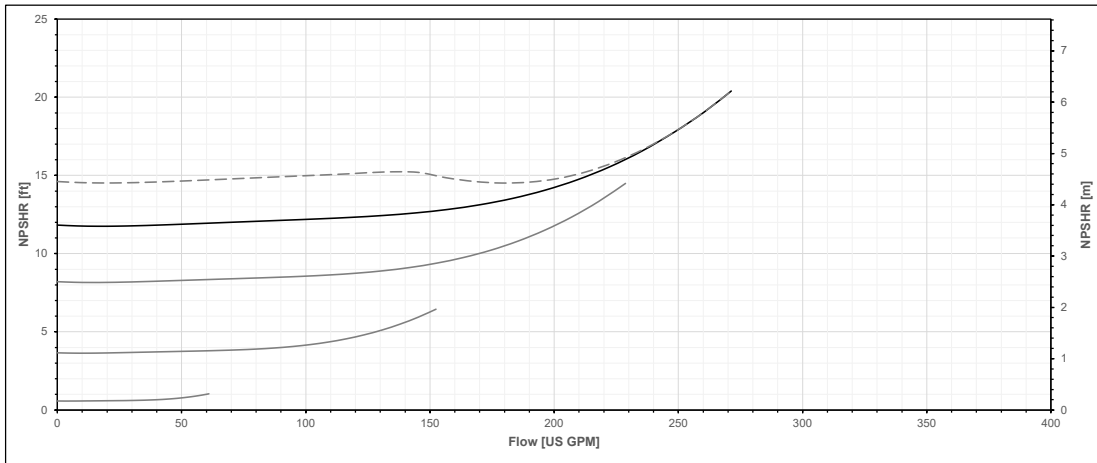
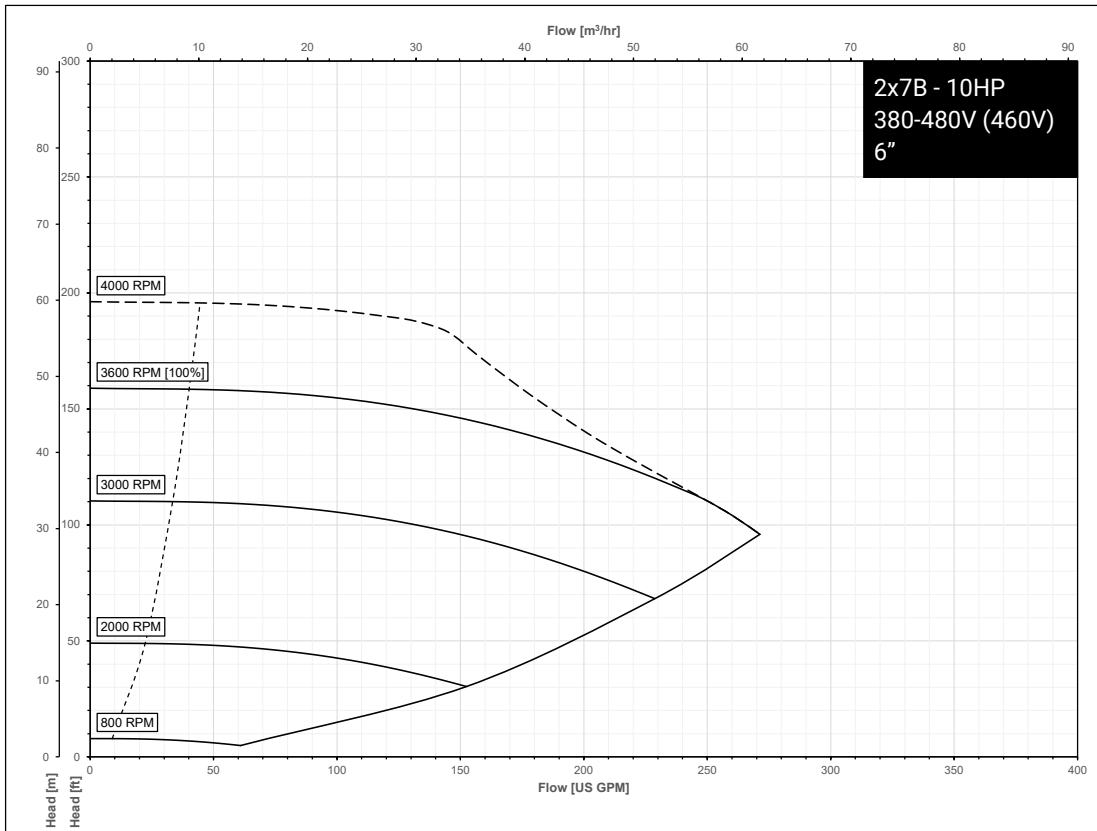

# Series e-80X Performance Curves for High Speed Models - 460V

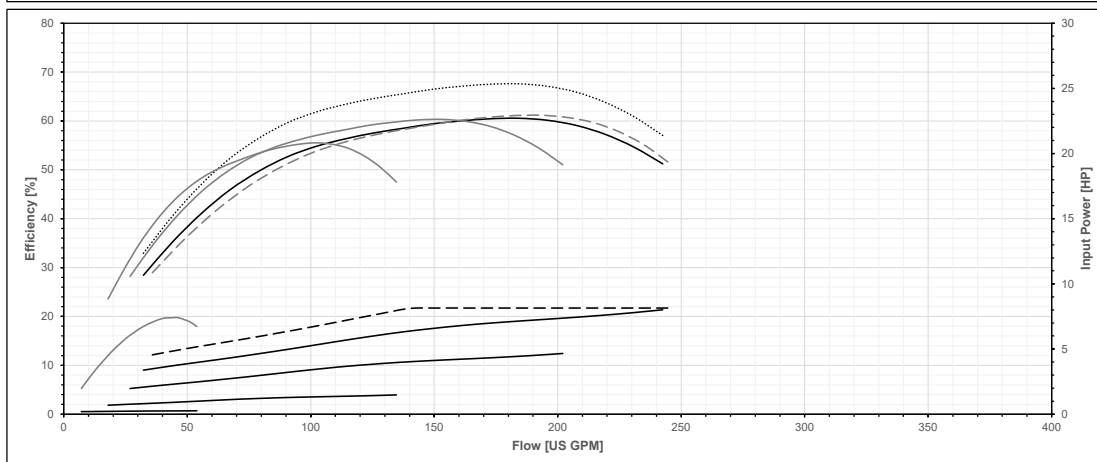
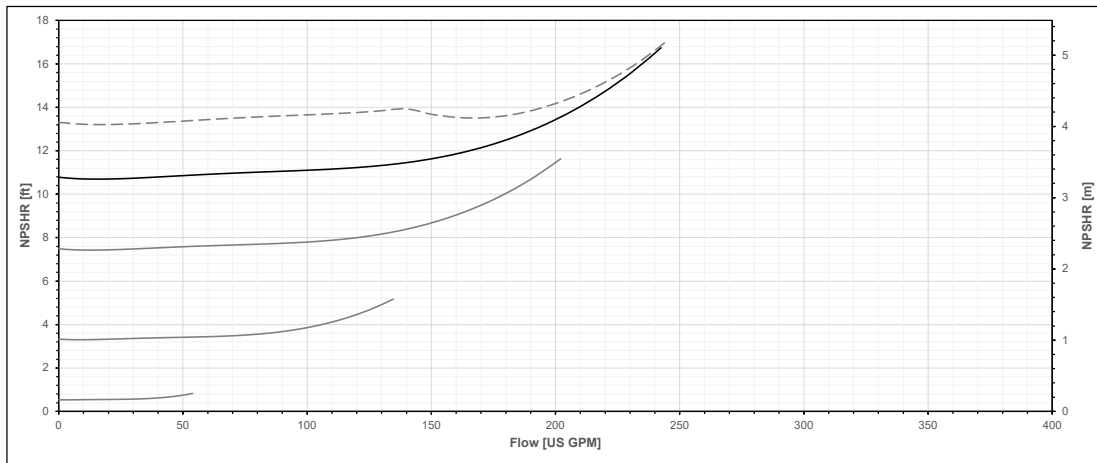
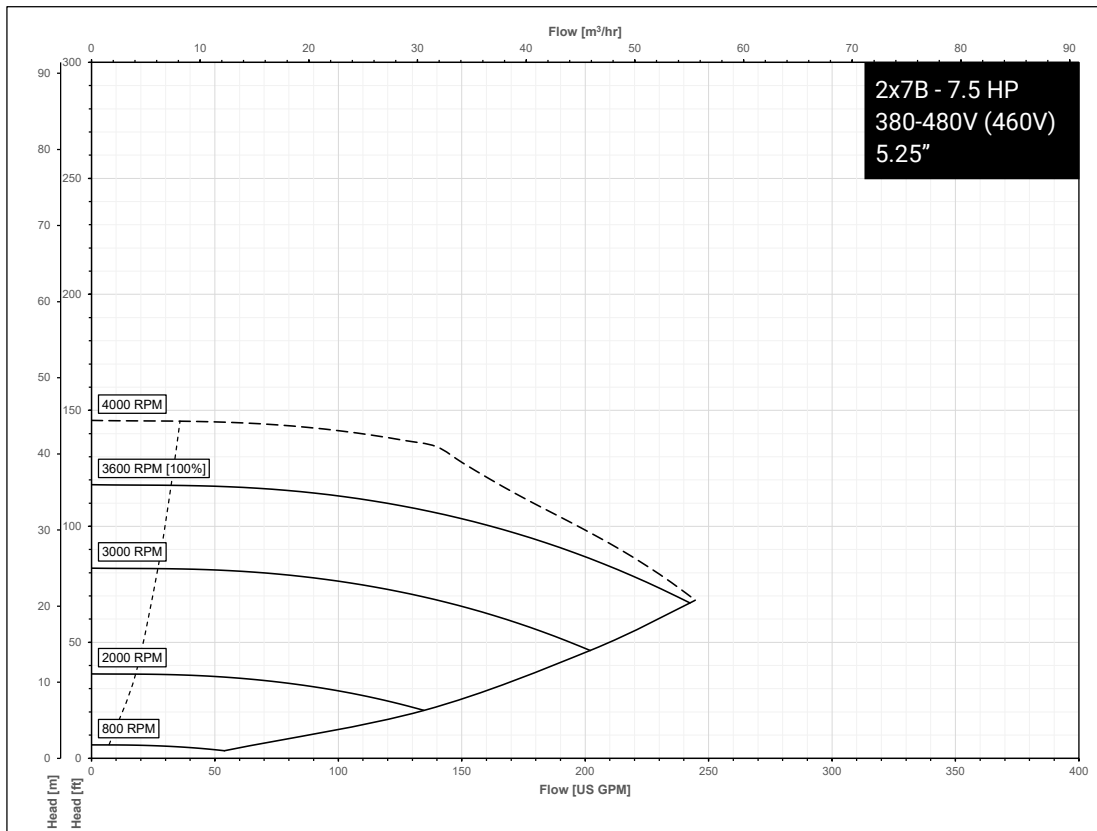

# Series e-80X Performance Curves for High Speed Models - 460V

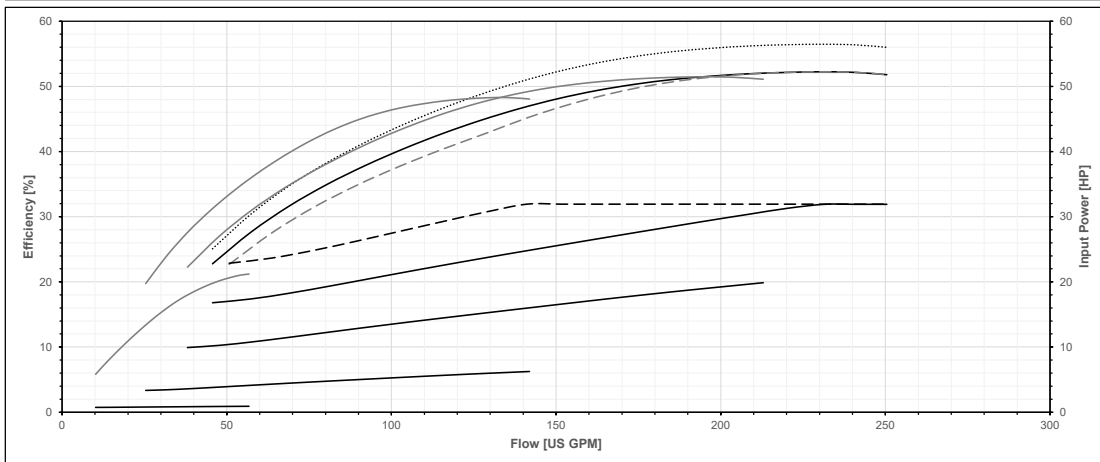
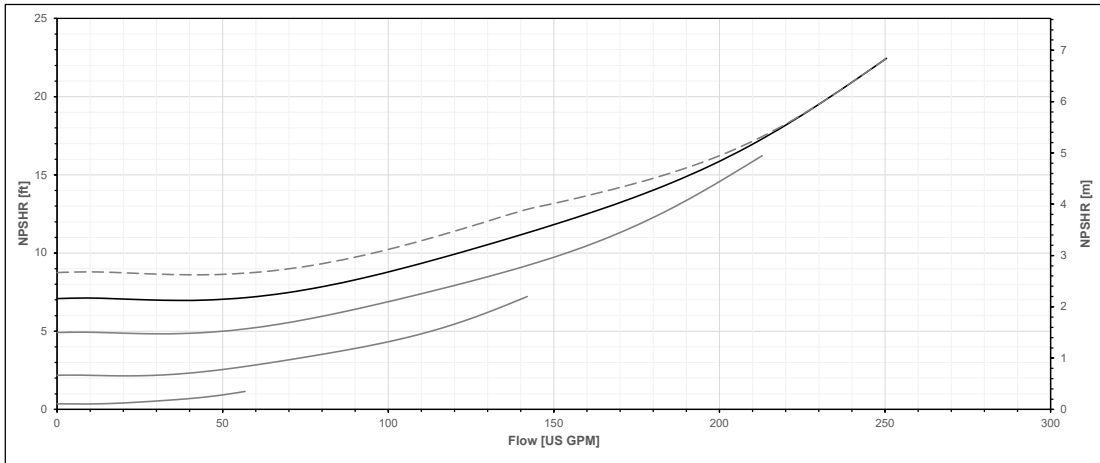
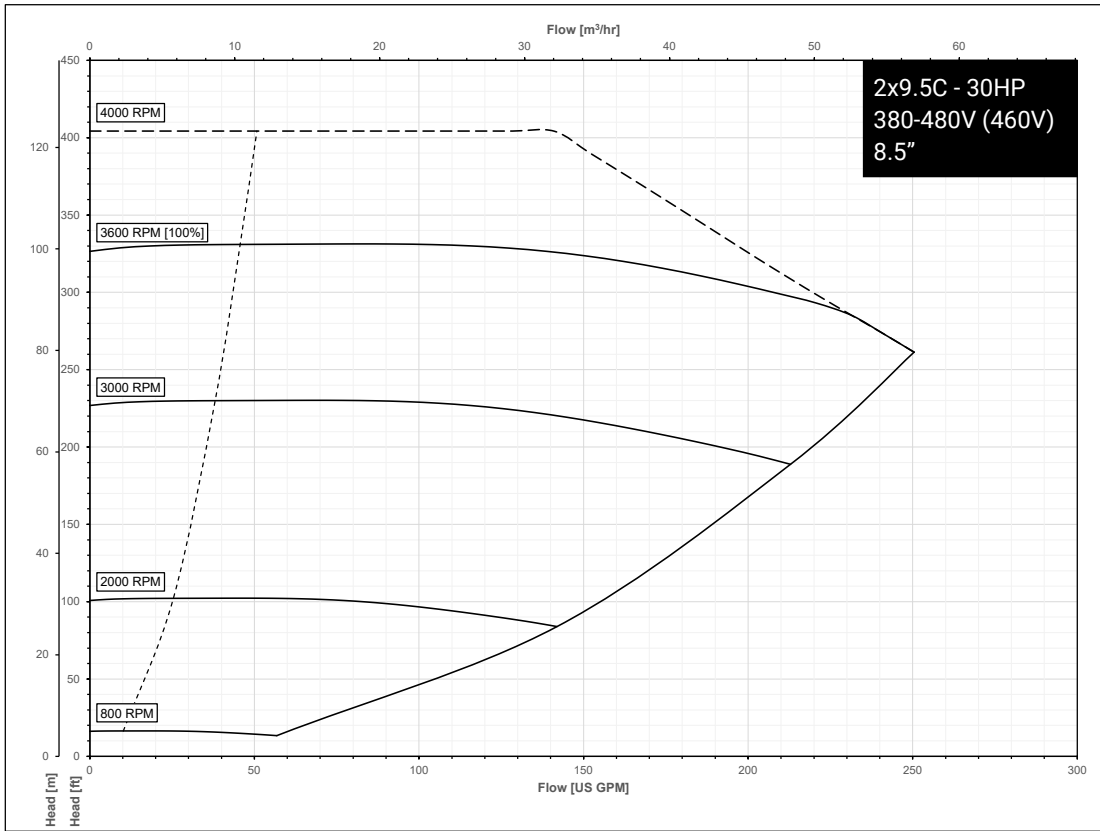

# Series e-80X Performance Curves for High Speed Models - 460V

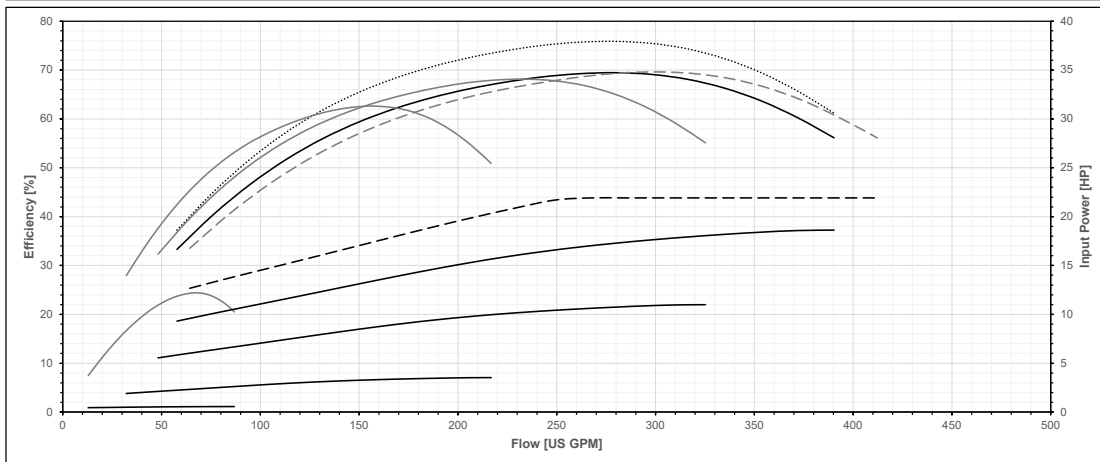
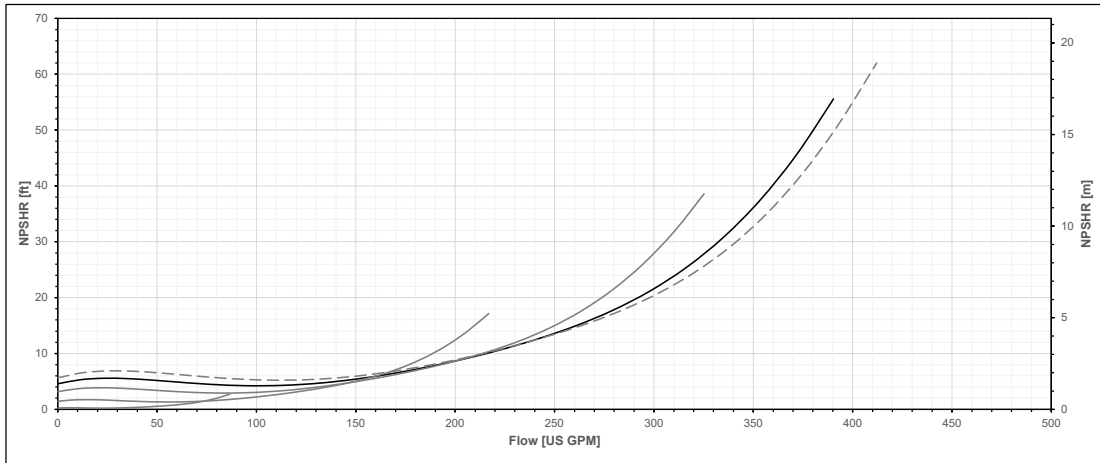
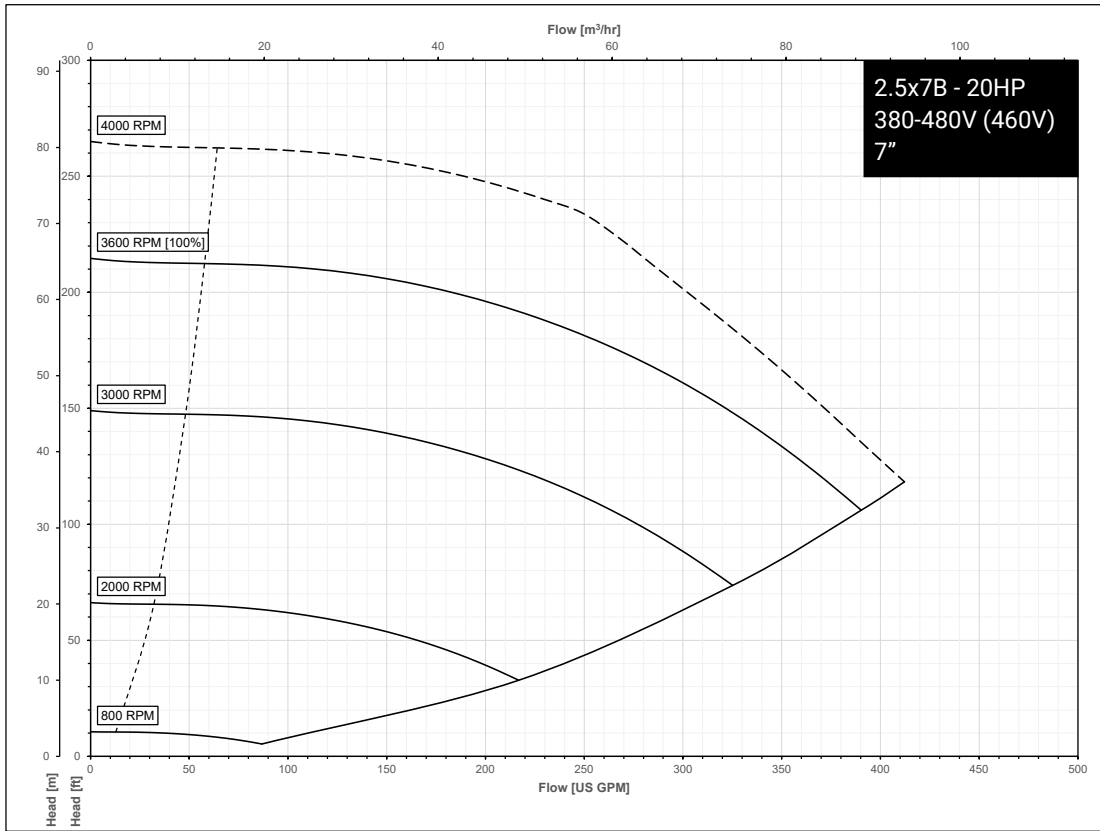

# Series e-80X Performance Curves for High Speed Models - 460V

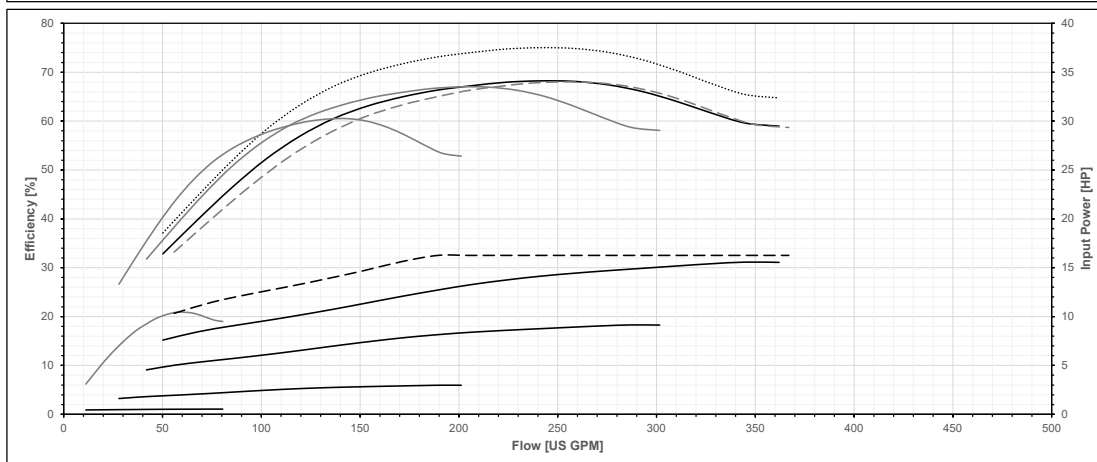
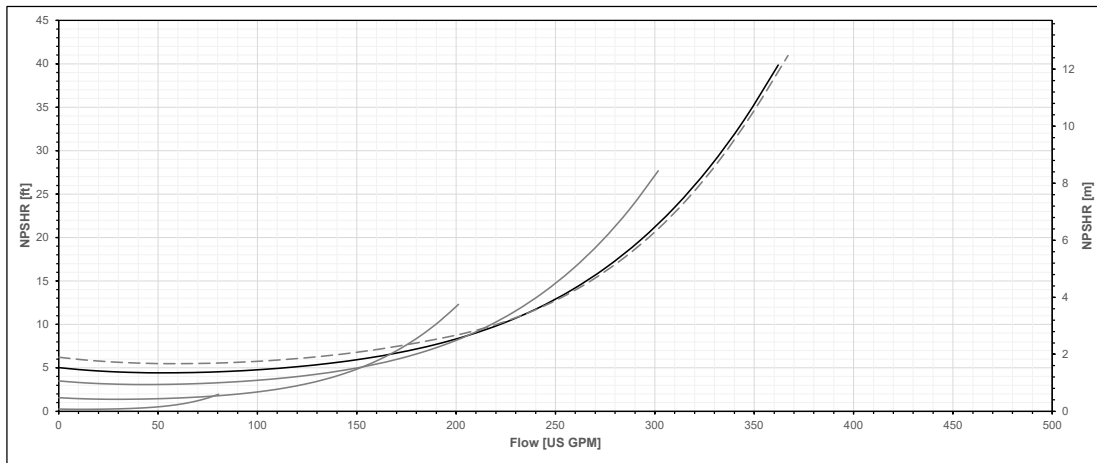
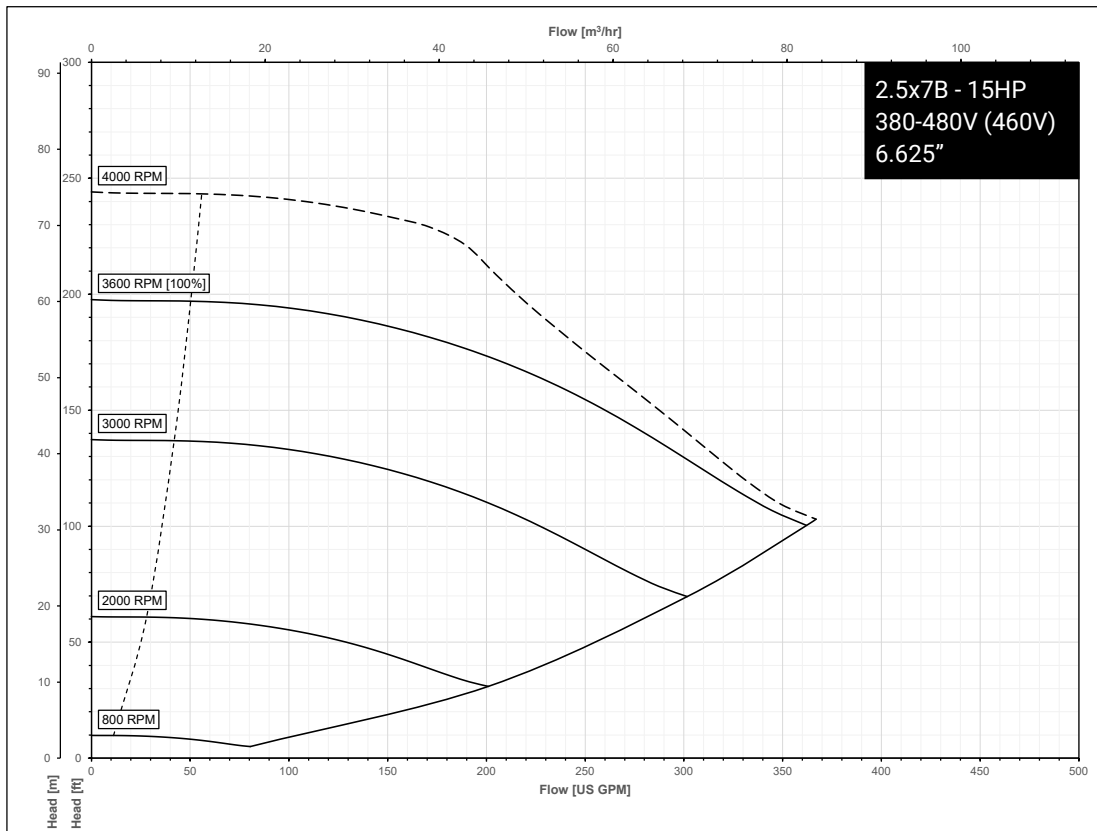

# Series e-80X Performance Curves for High Speed Models - 460V

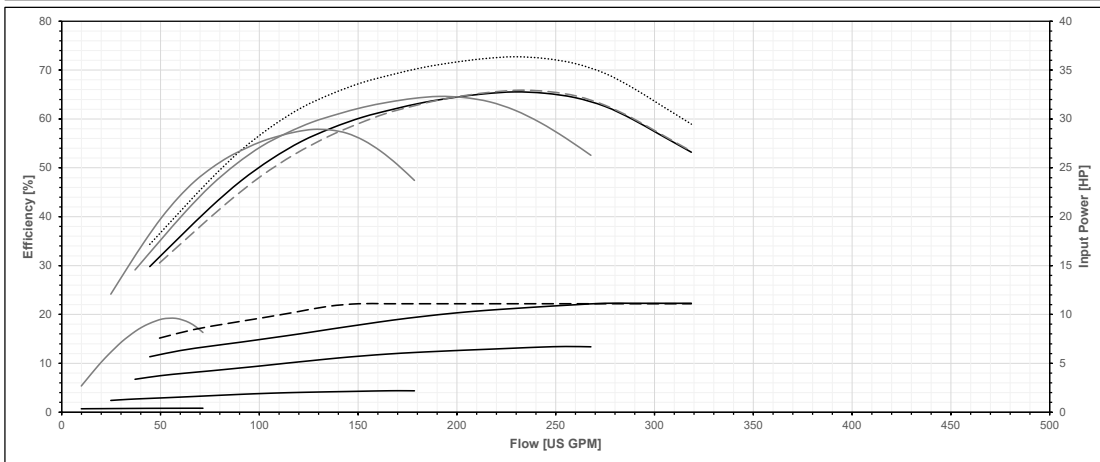
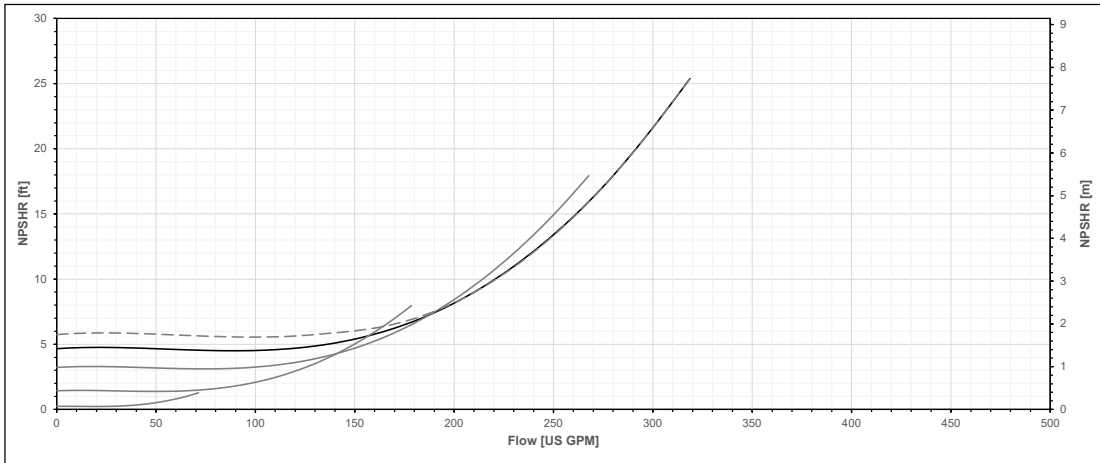
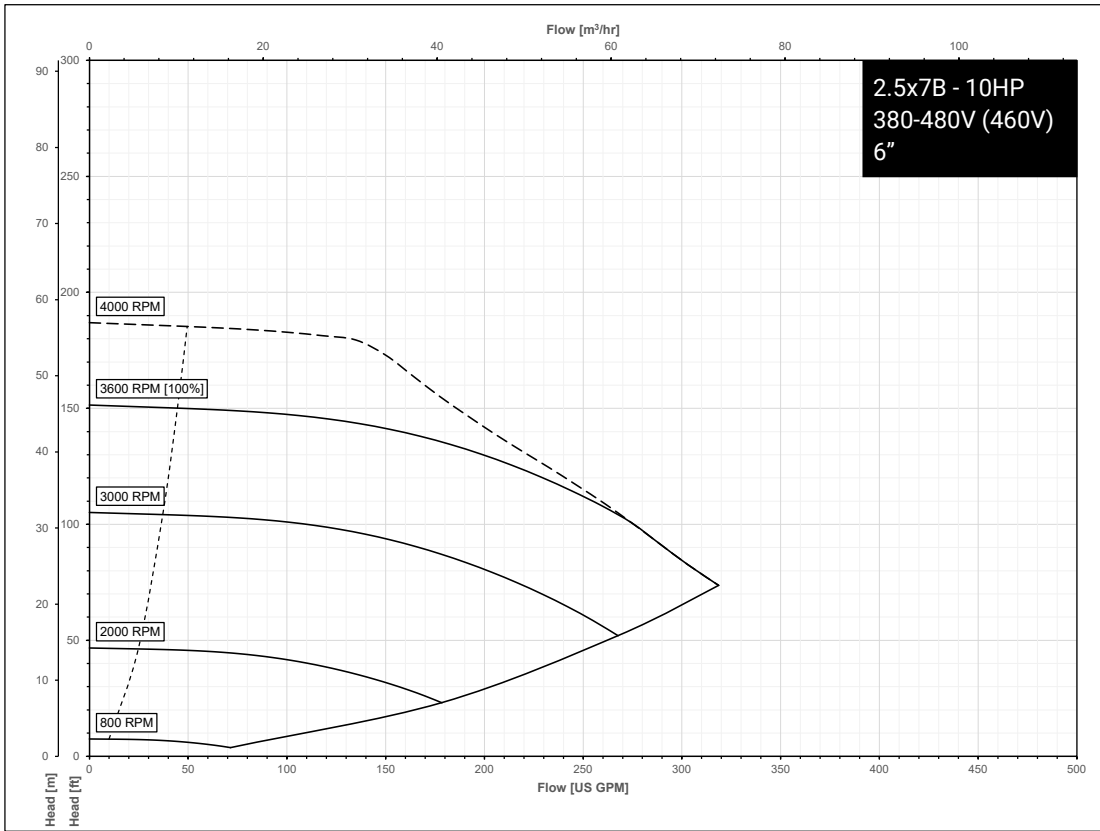

# Series e-80X Performance Curves for High Speed Models - 460V

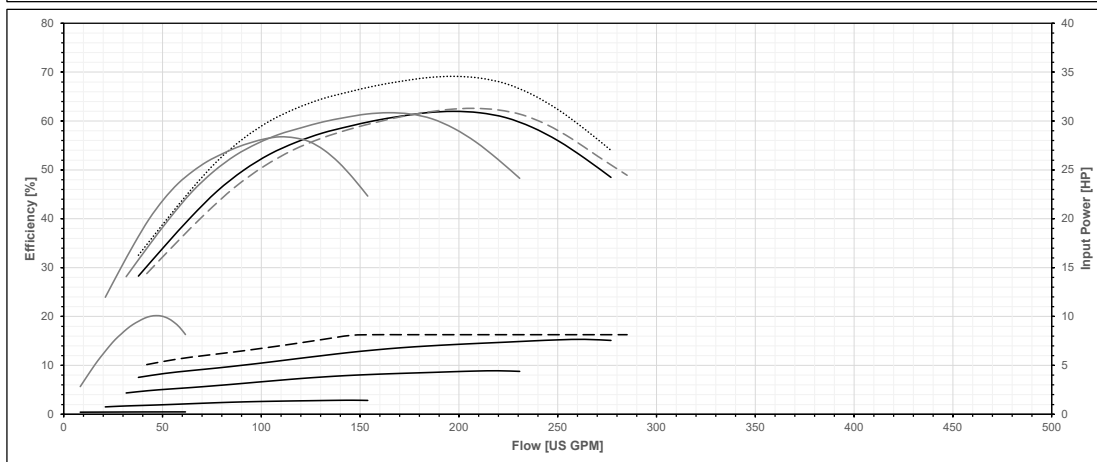
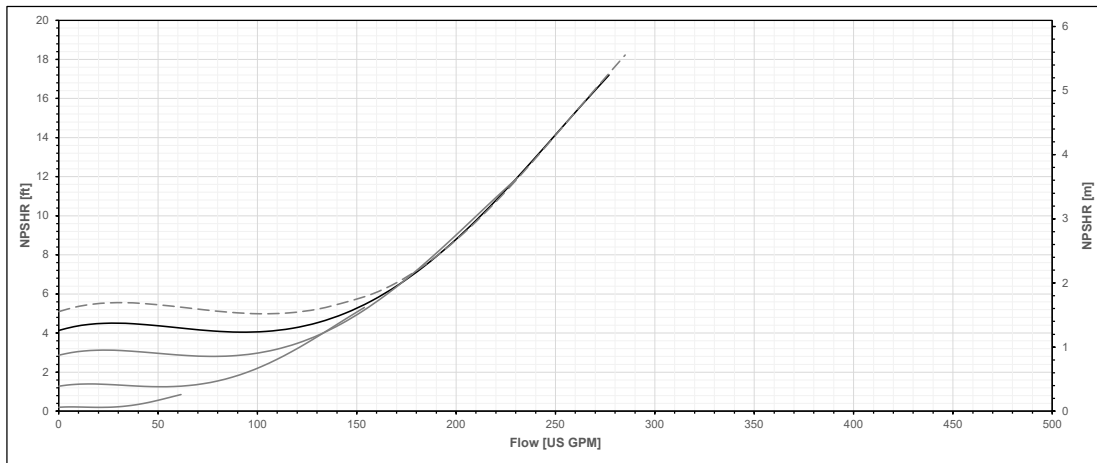
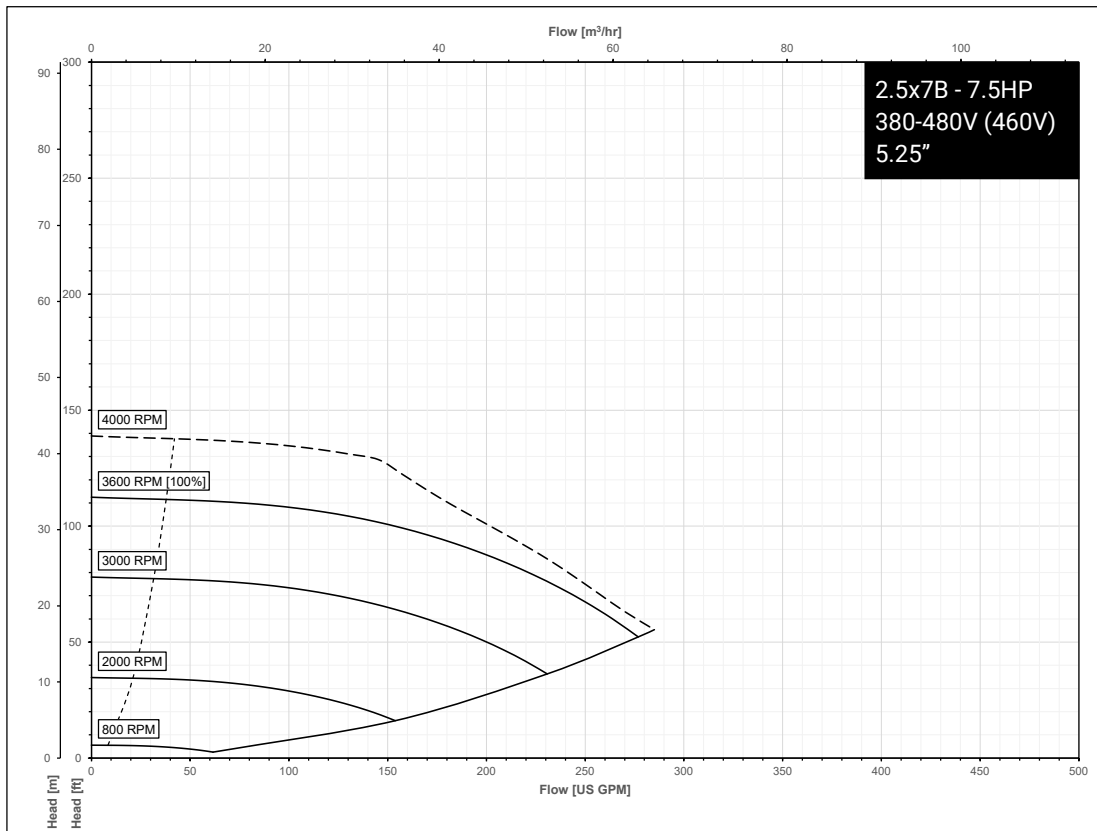

# Series e-80X Performance Curves for High Speed Models - 460V

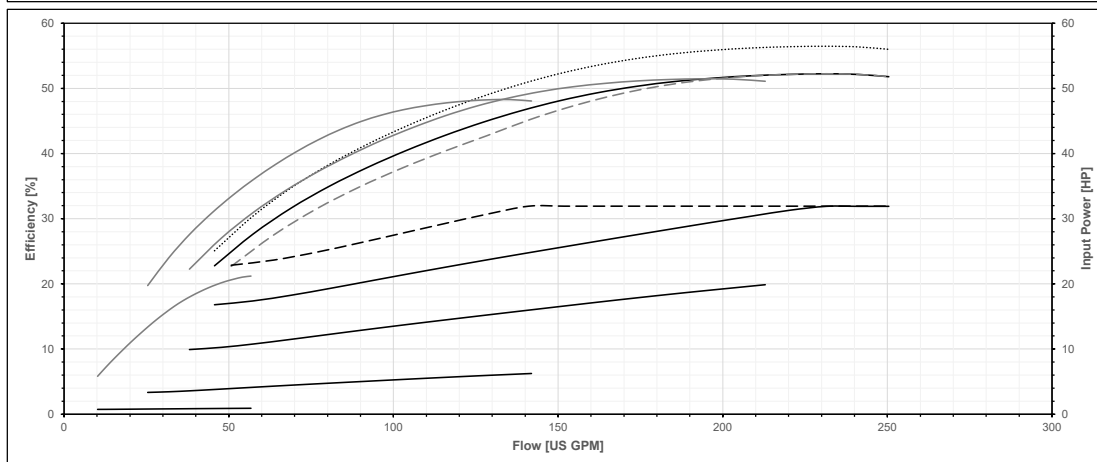
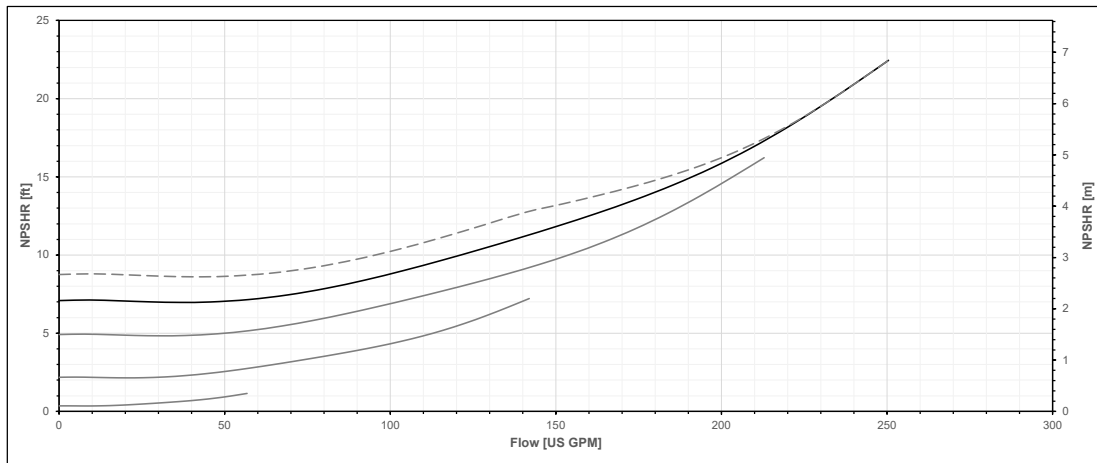
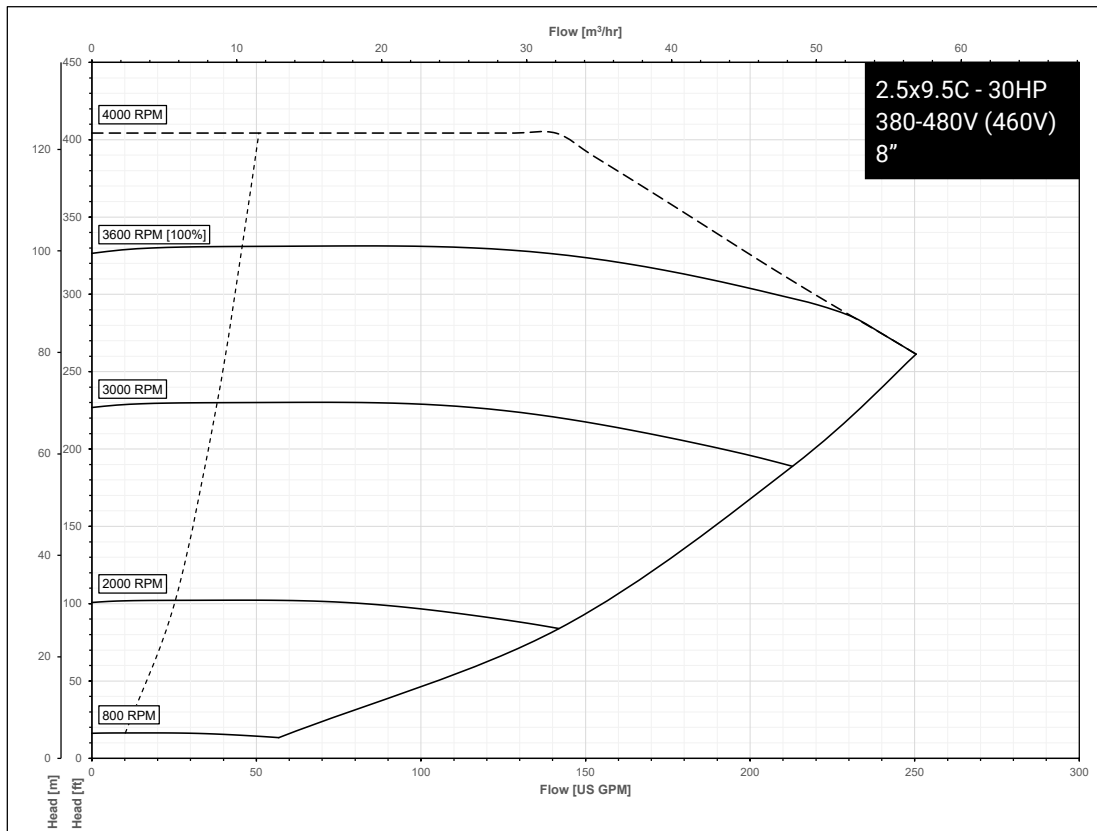

# Series e-80X Performance Curves for High Speed Models - 460V

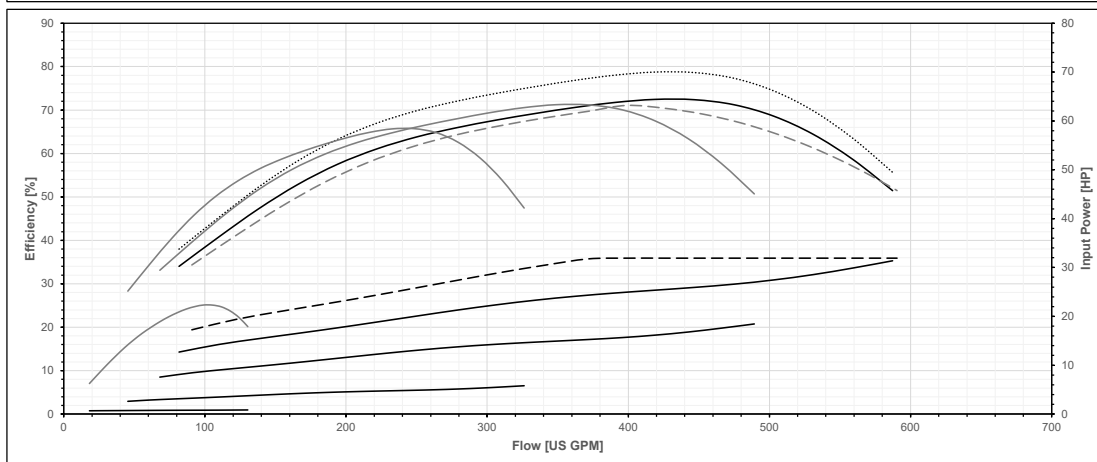
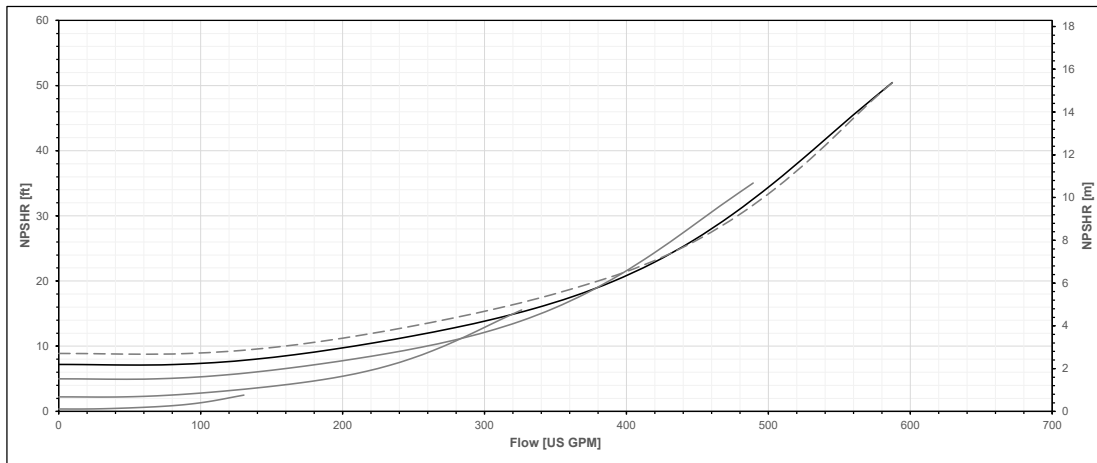
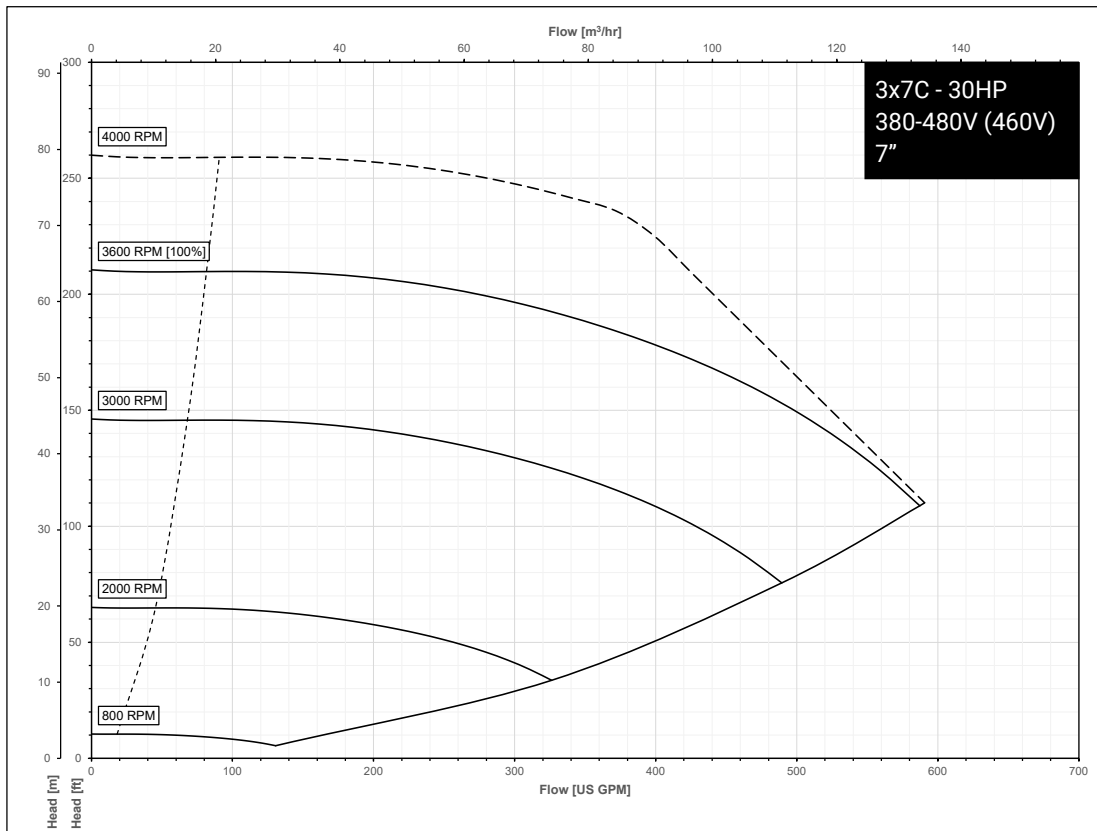

# Series e-80X Performance Curves for High Speed Models - 460V

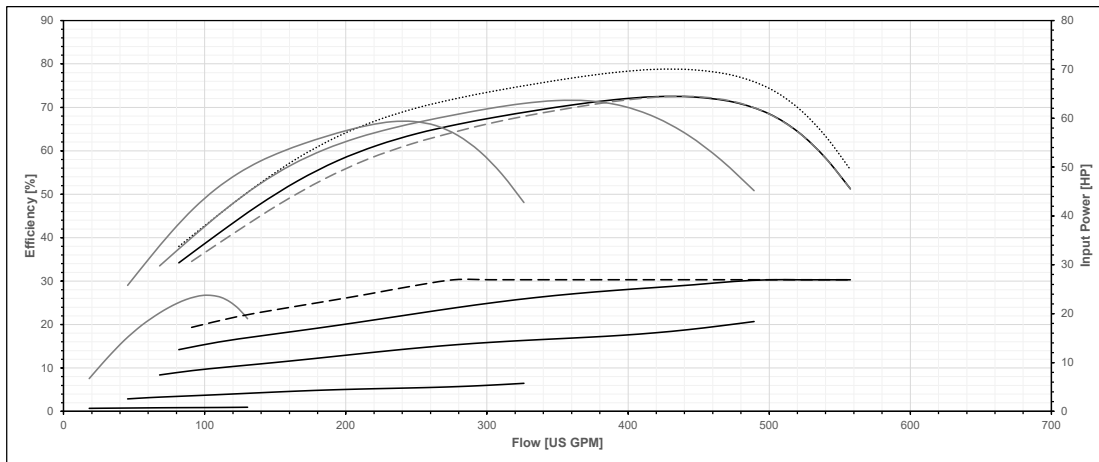
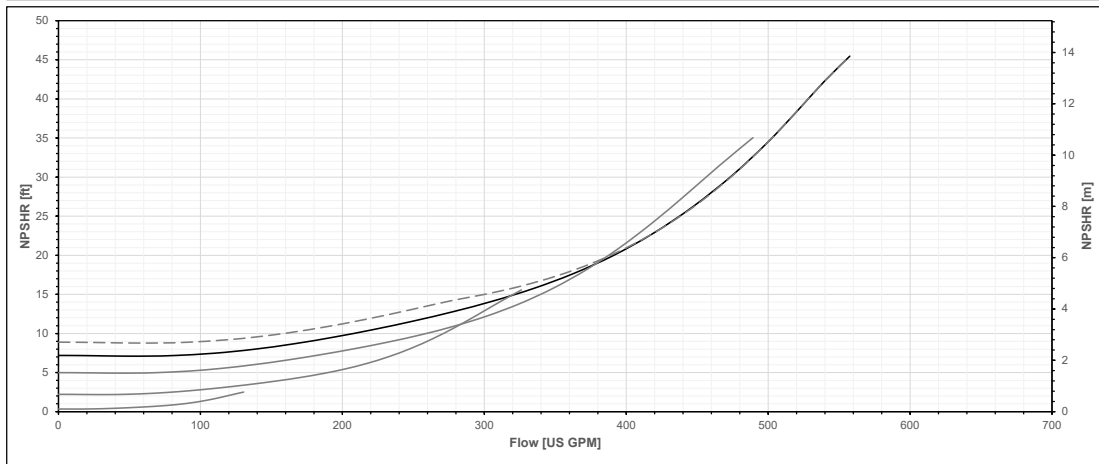
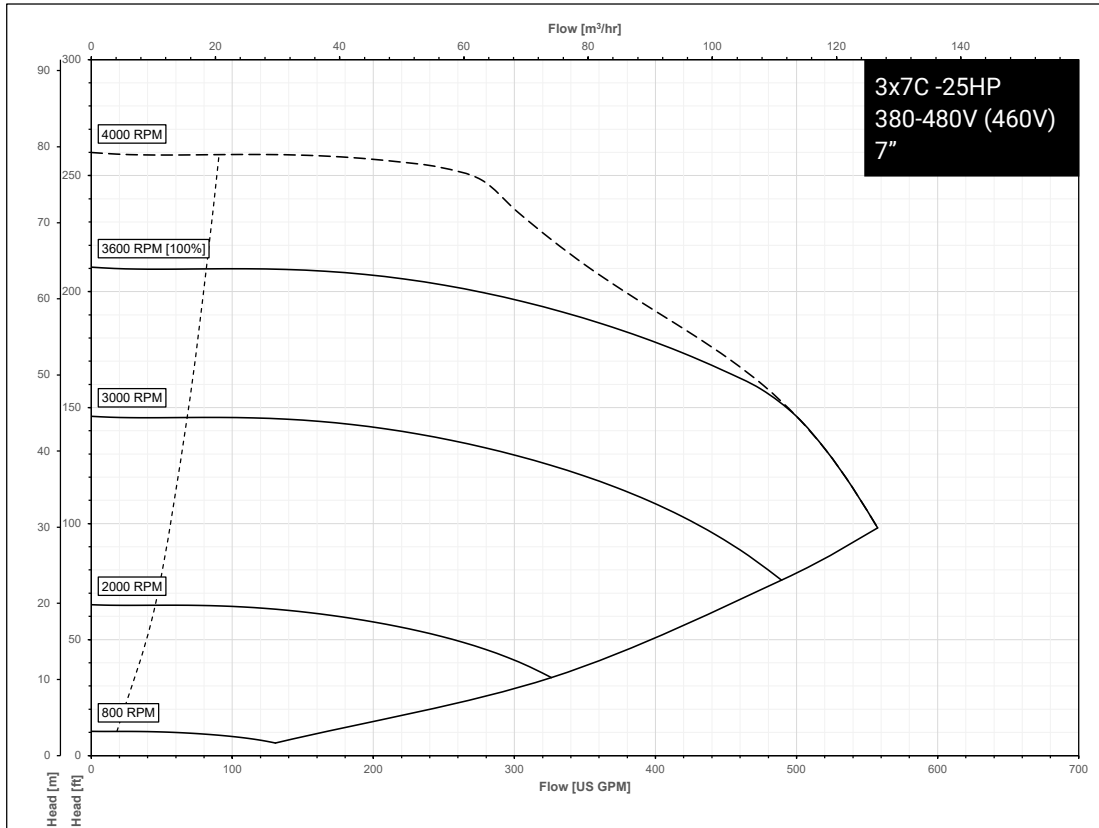

# Series e-80X Performance Curves for High Speed Models - 460V

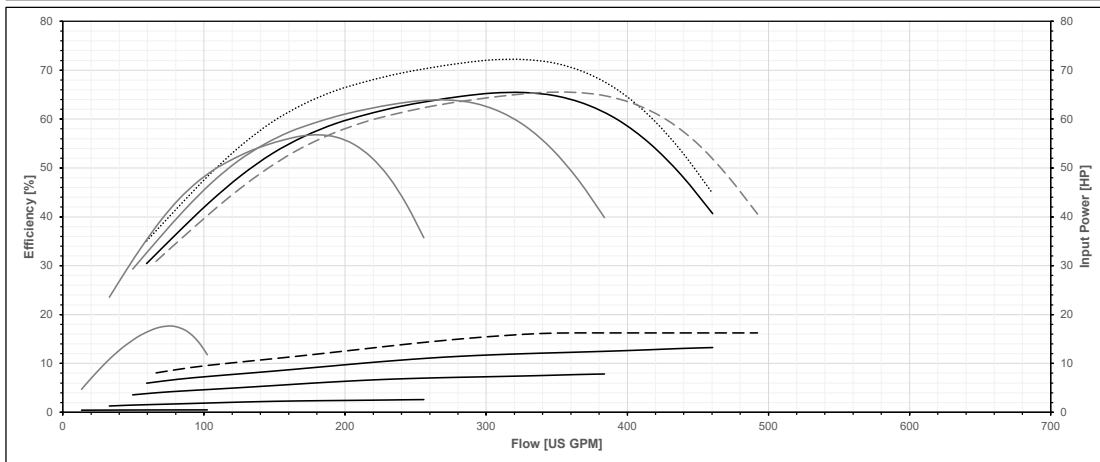
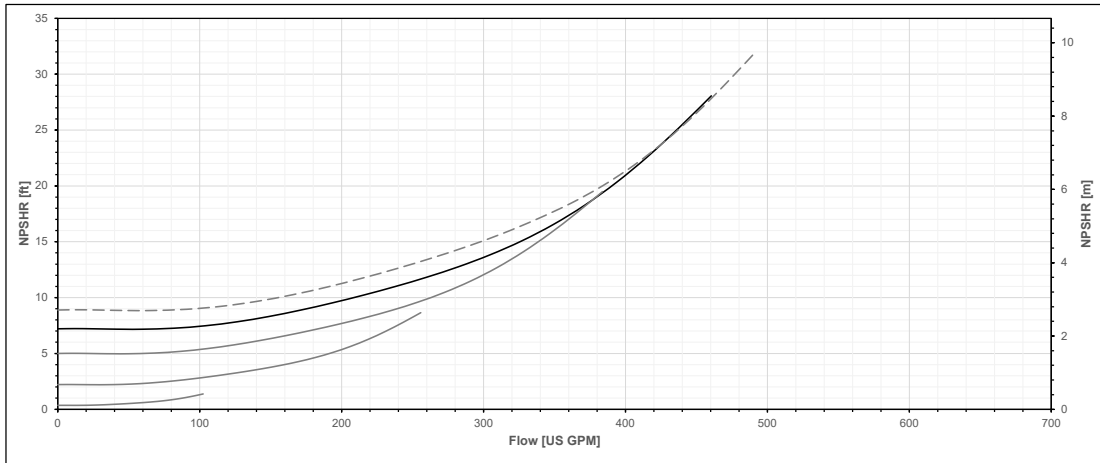
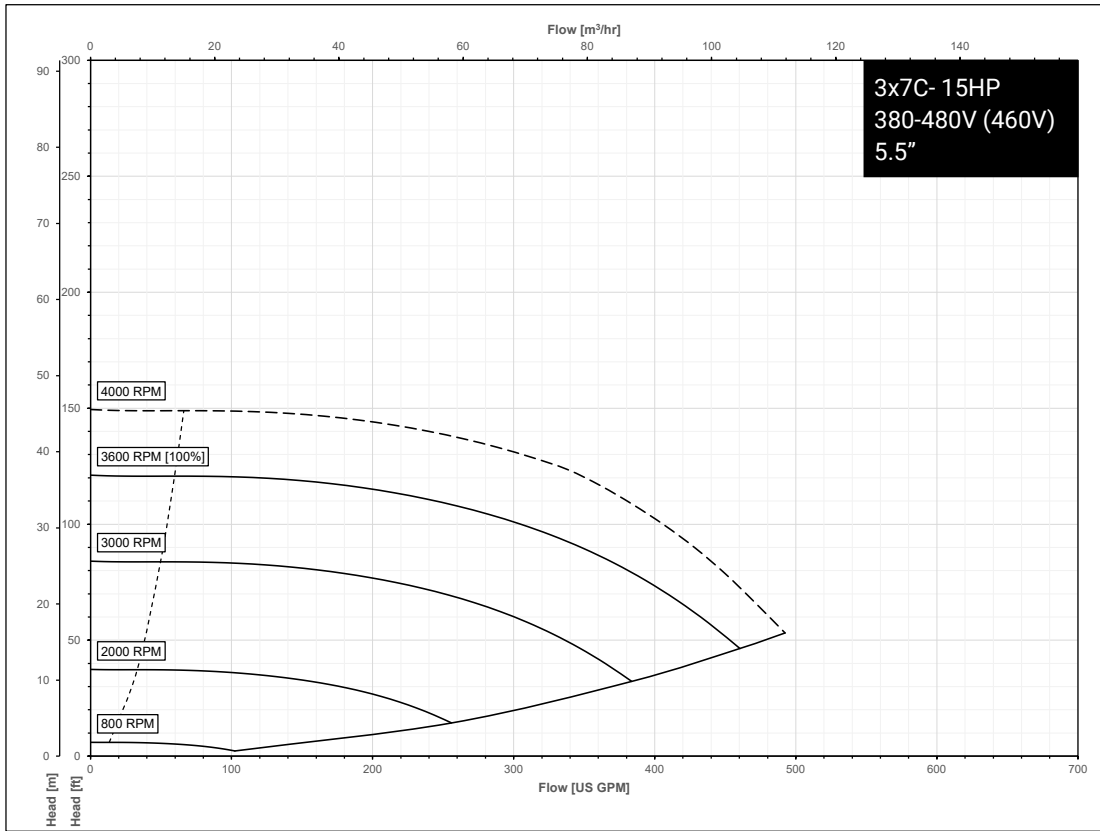

# Series e-80X Performance Curves for High Speed Models - 460V

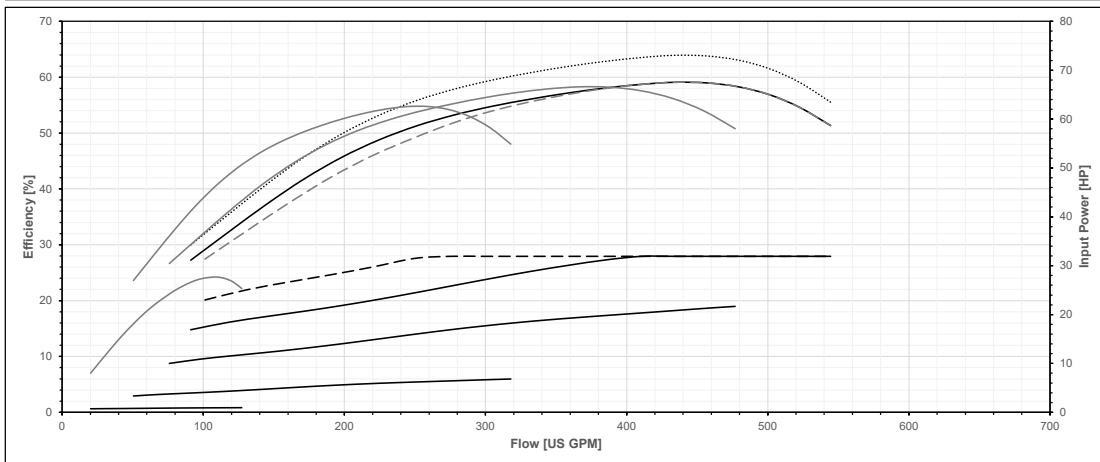
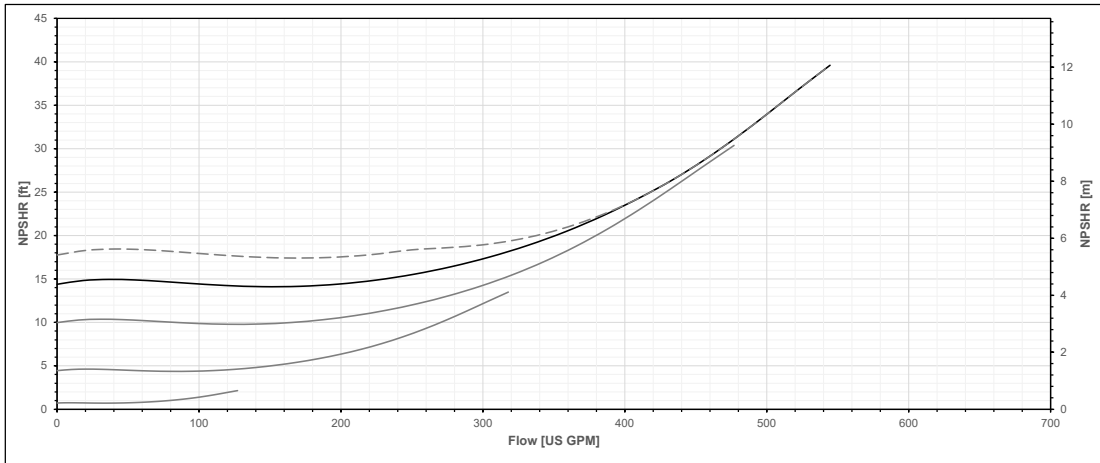
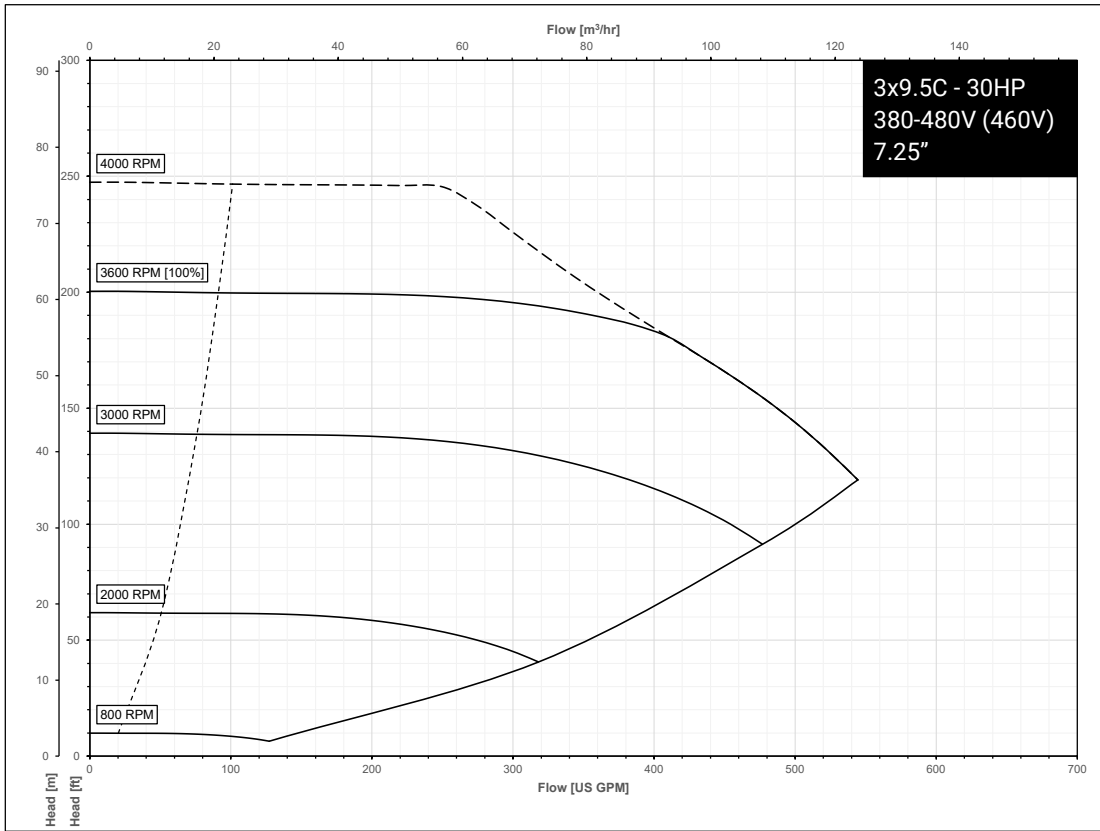

# Series e-80X Performance Curves for High Speed Models - 460V

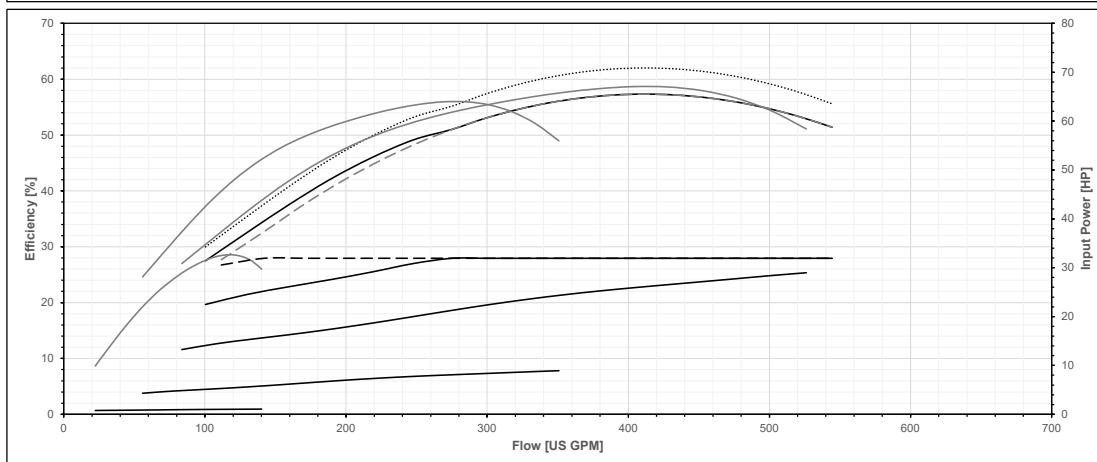
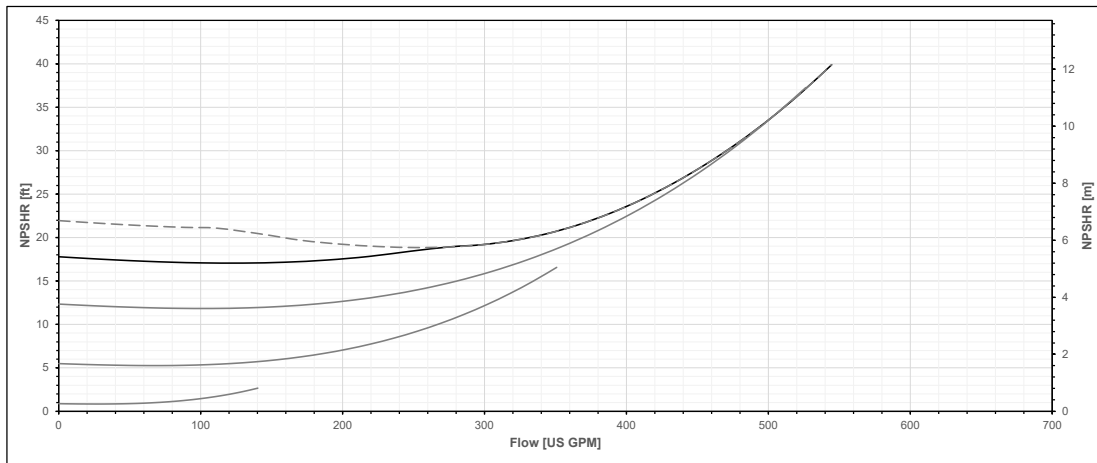
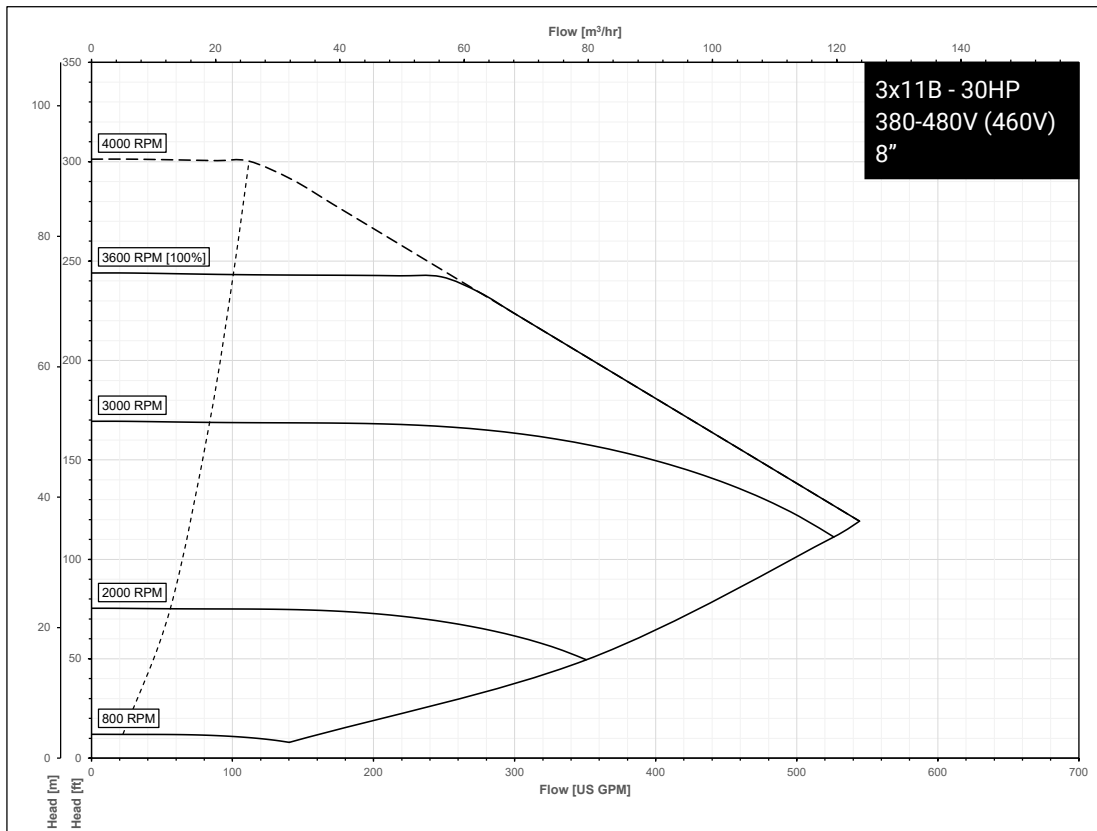

# Series e-80X Performance Curves for High Speed Models - 460V

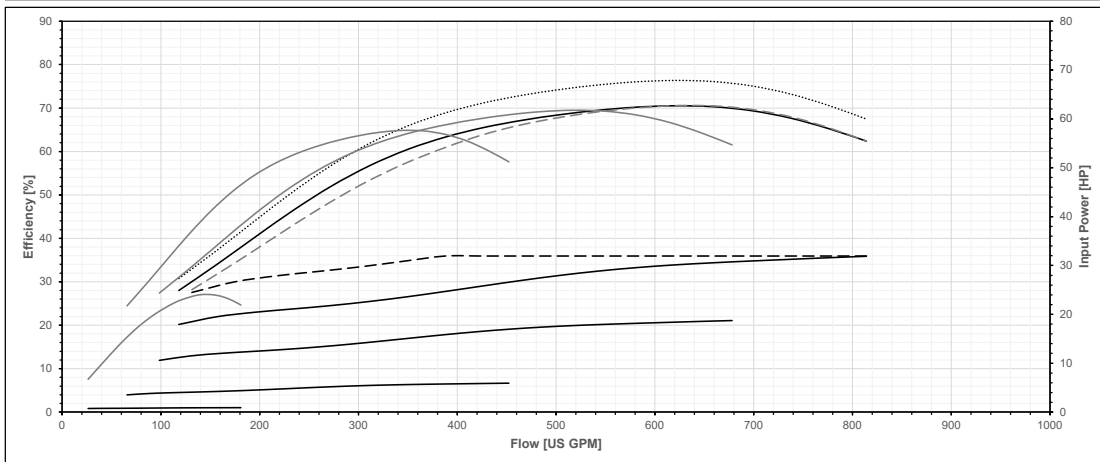
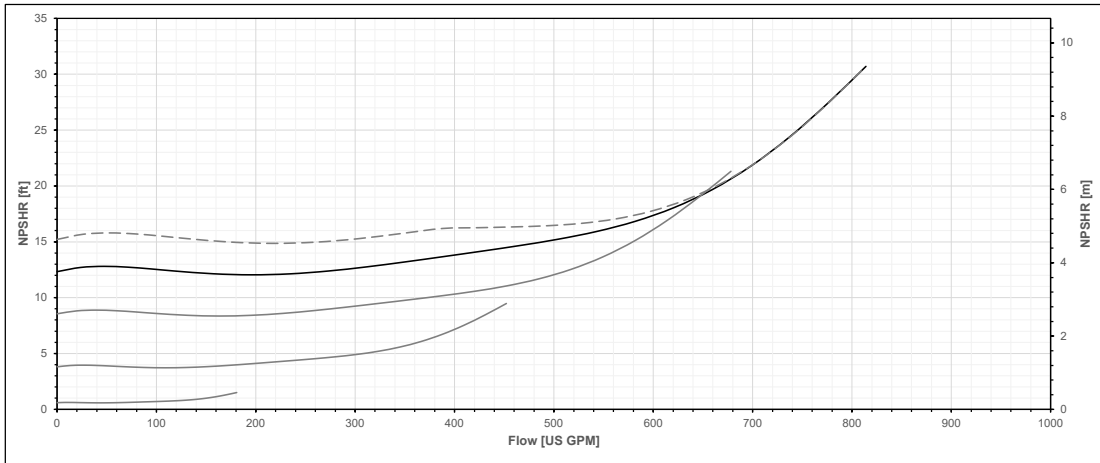
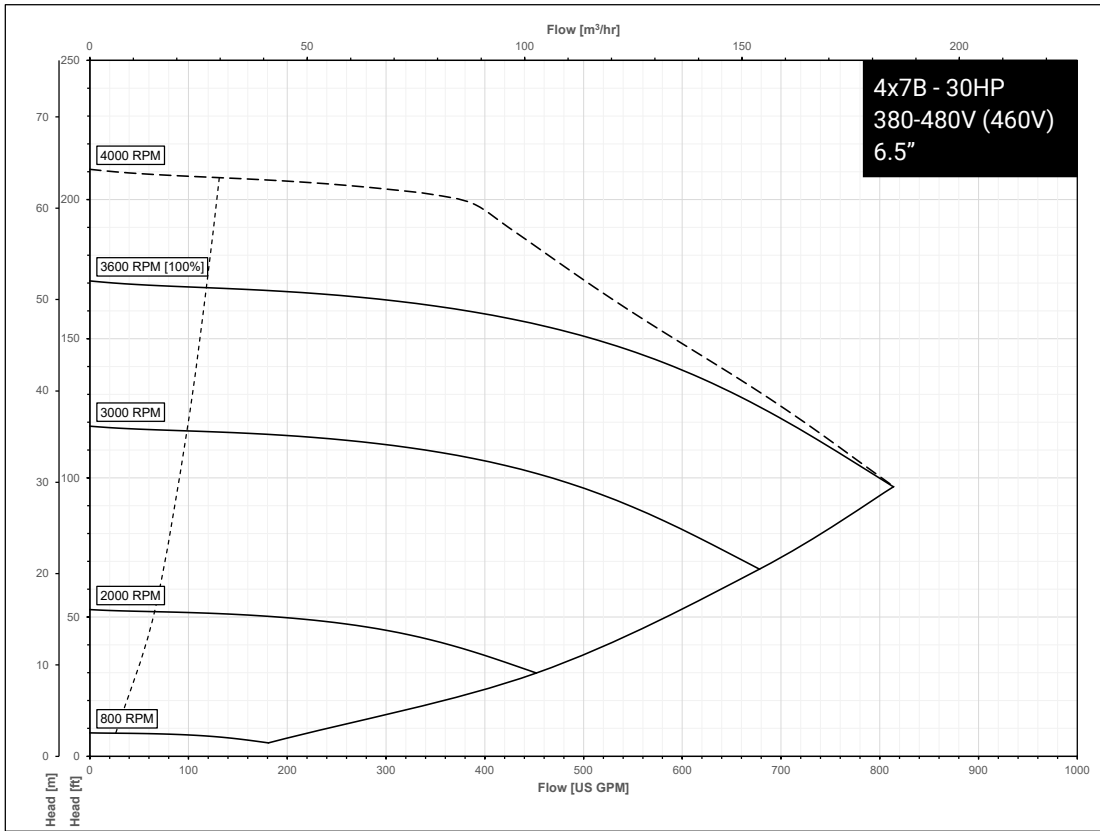

# Series e-80X Performance Curves for High Speed Models - 460V

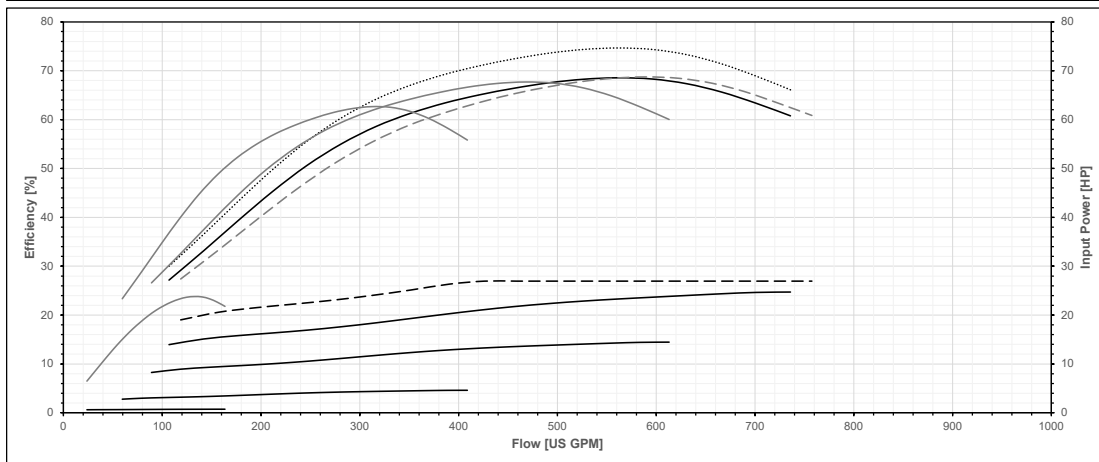
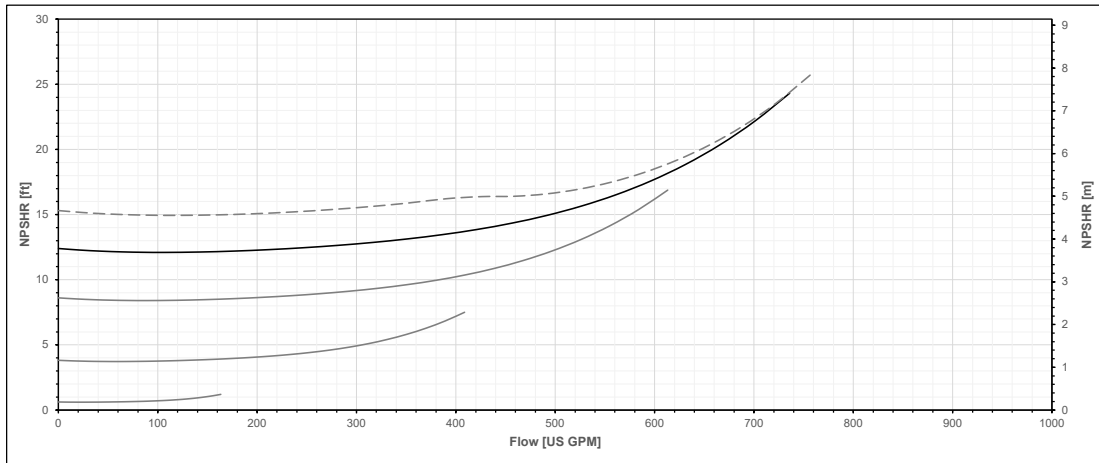
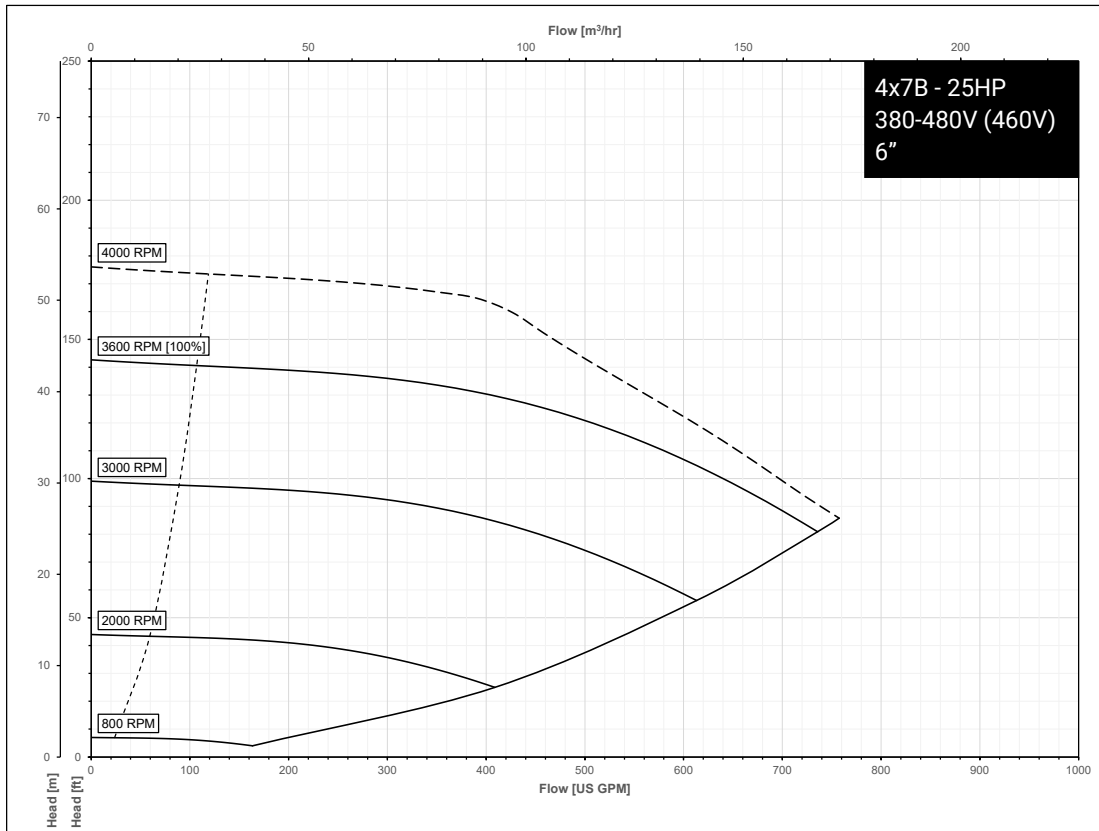

# Series e-80X Performance Curves for High Speed Models - 460V

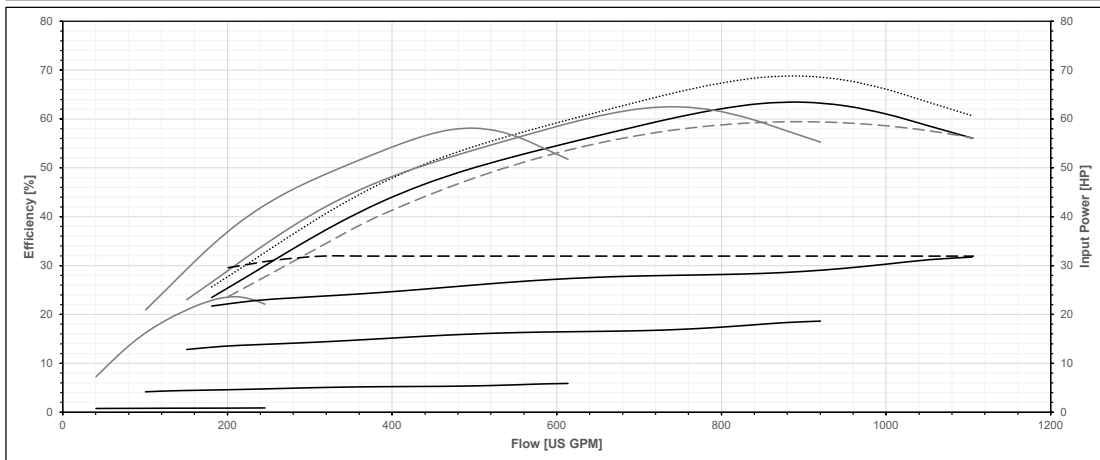
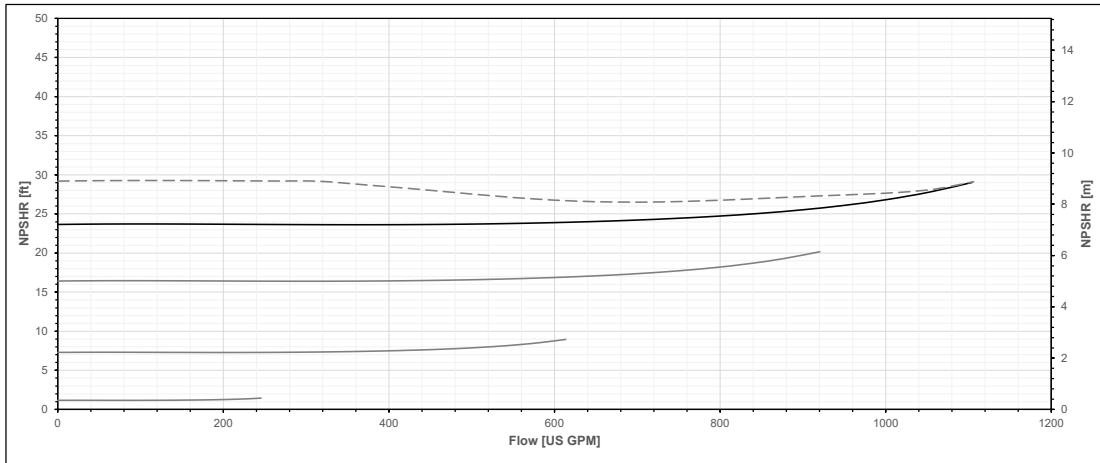
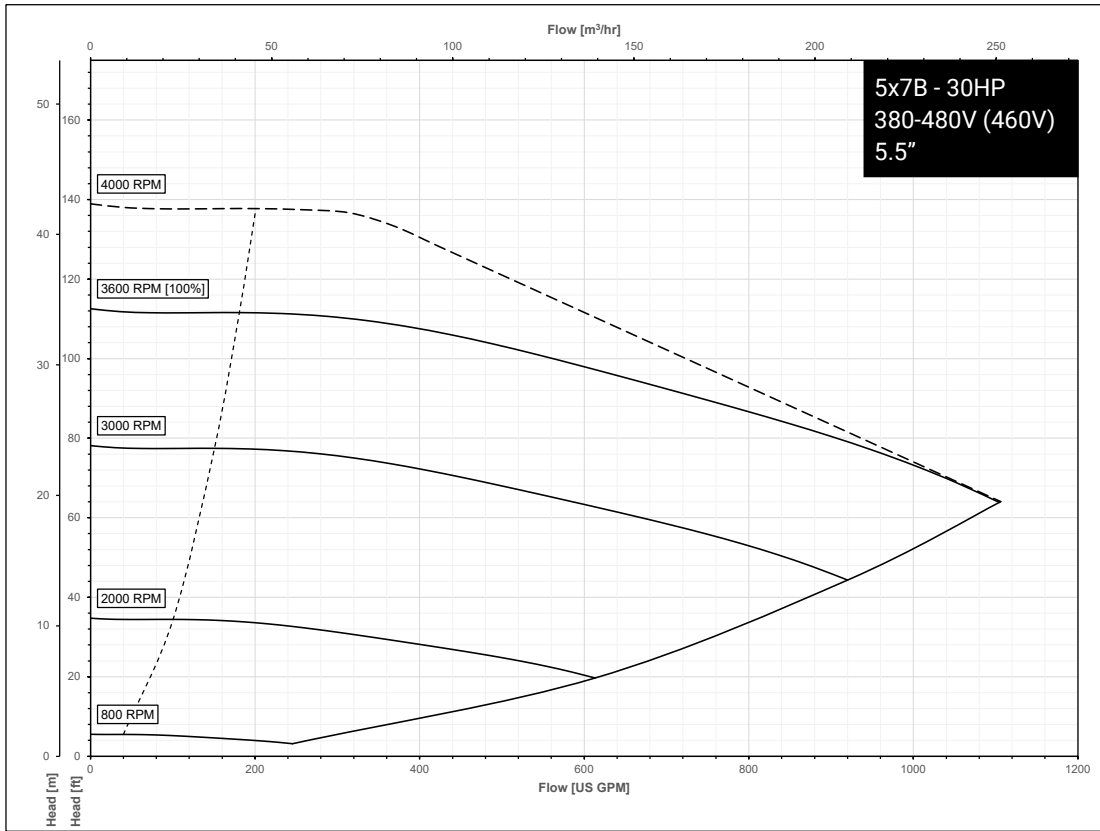

# Series e-80X Performance Curves for High Speed Models - 460V

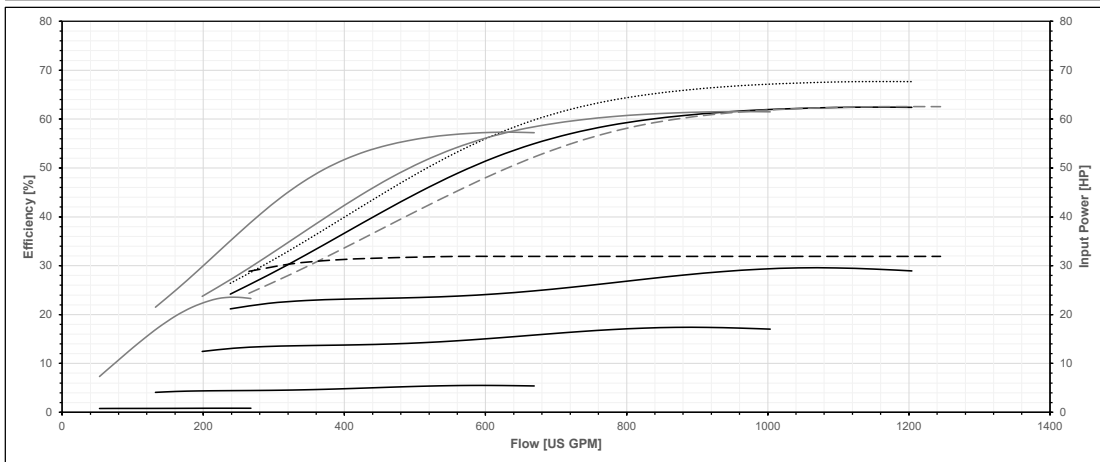
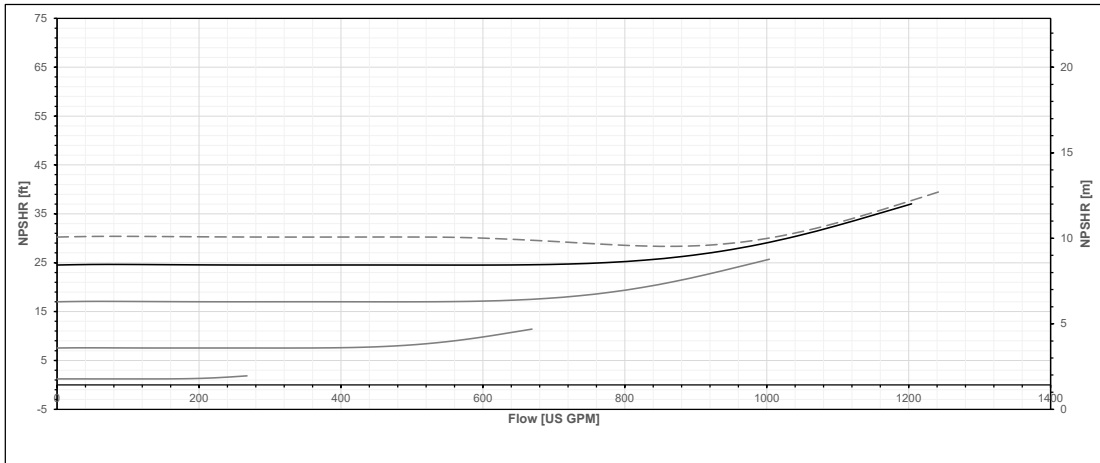
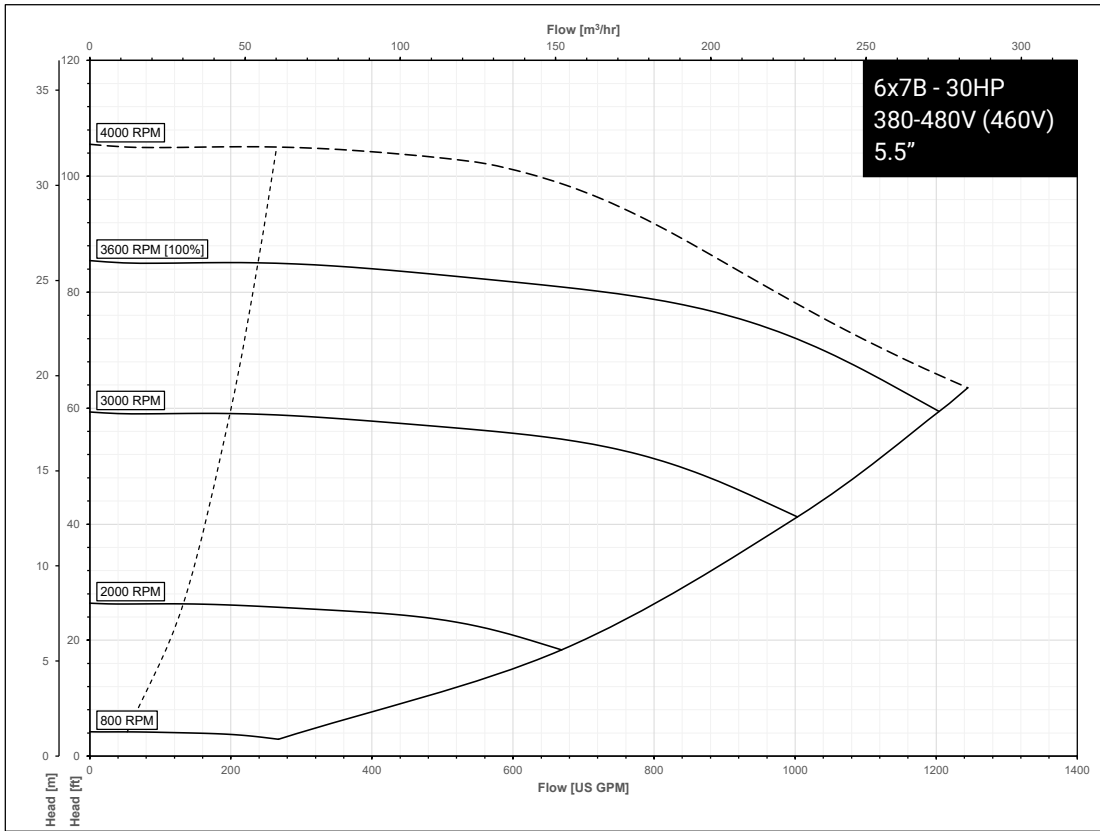

# Series e-80X Performance Curves for High Speed Models - 230V

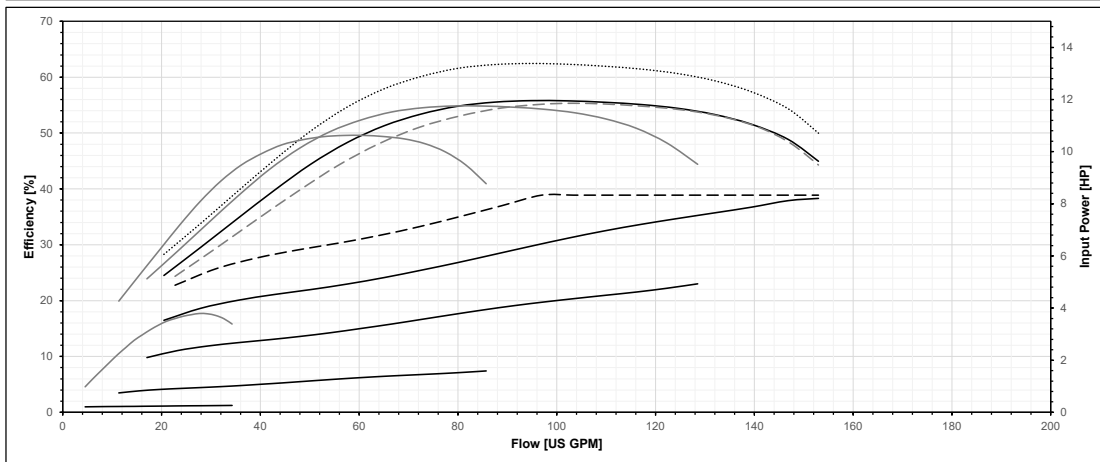
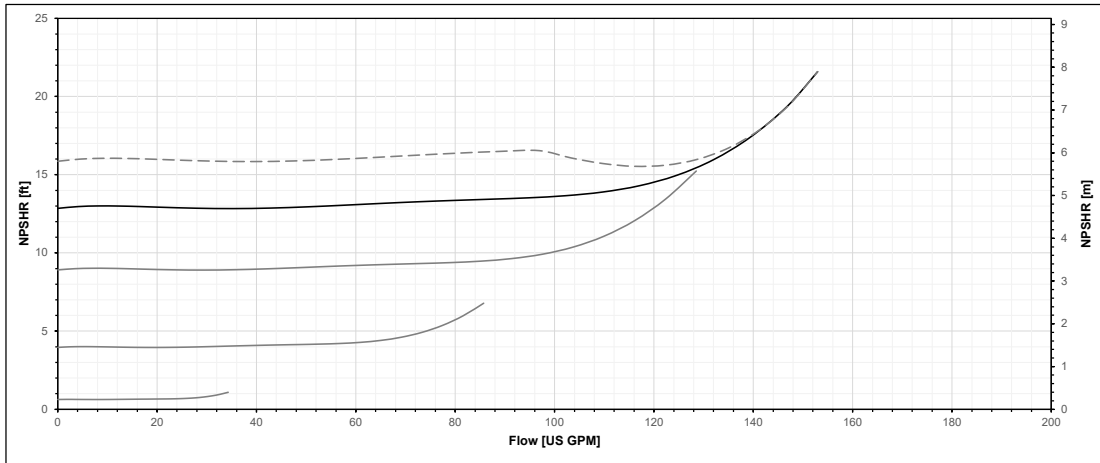
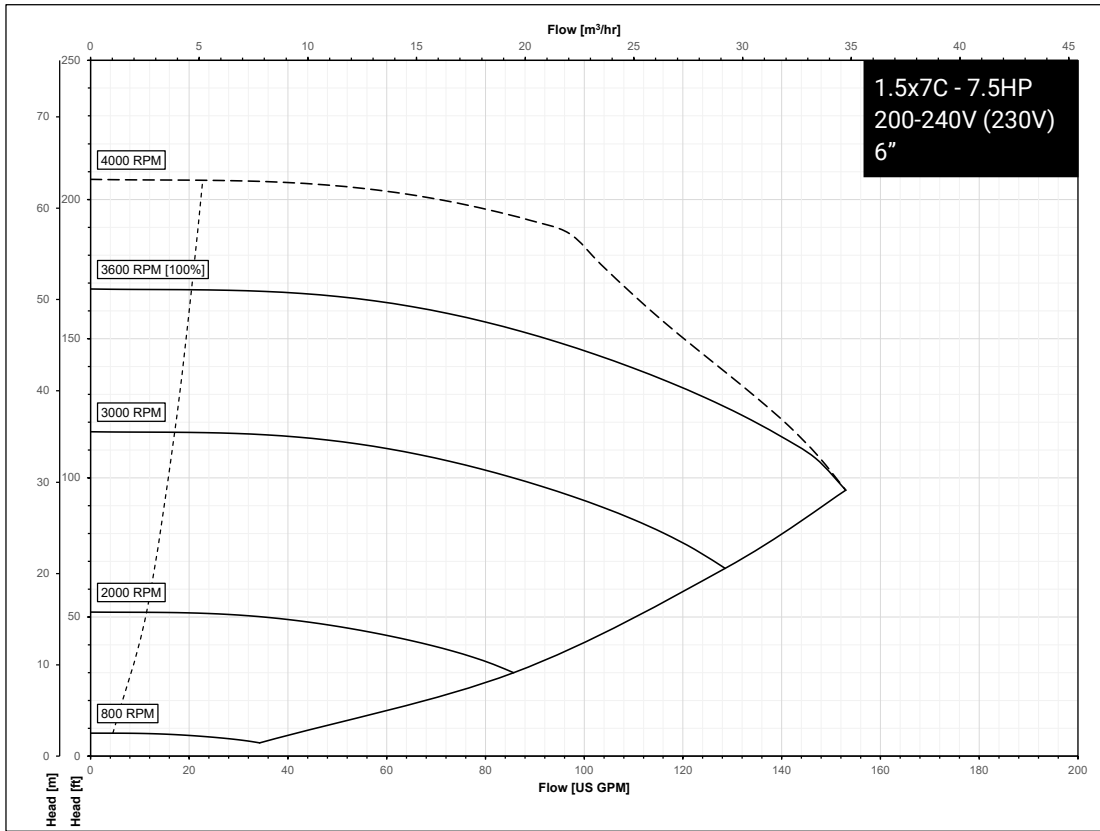

# Series e-80X Performance Curves for High Speed Models - 230V

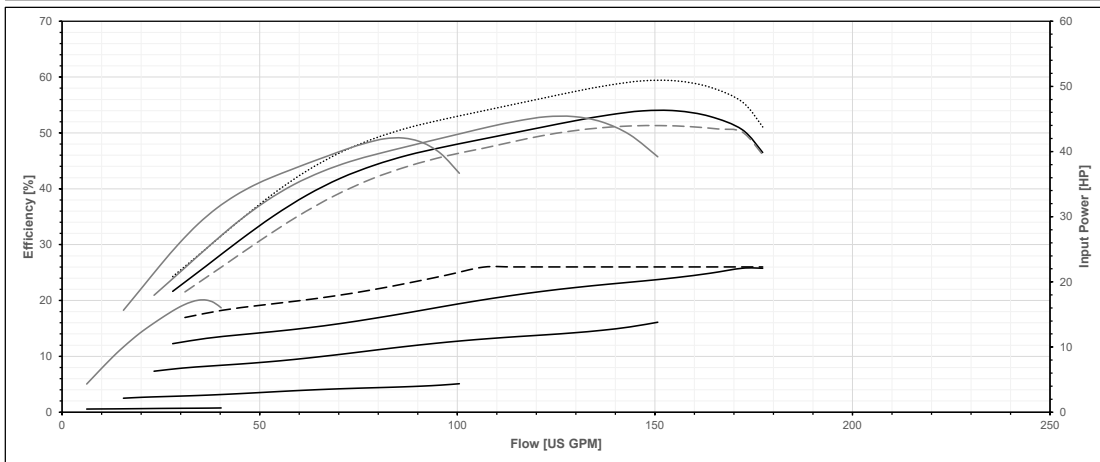
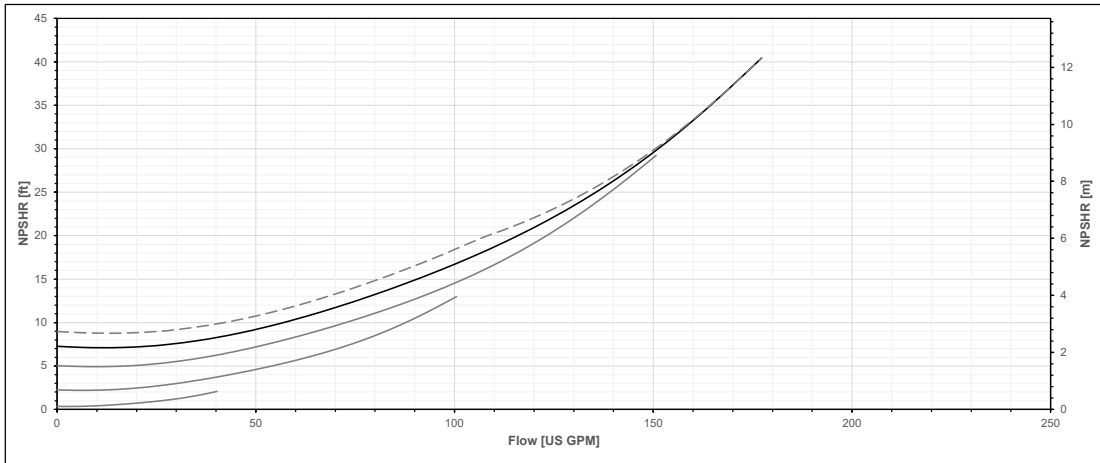
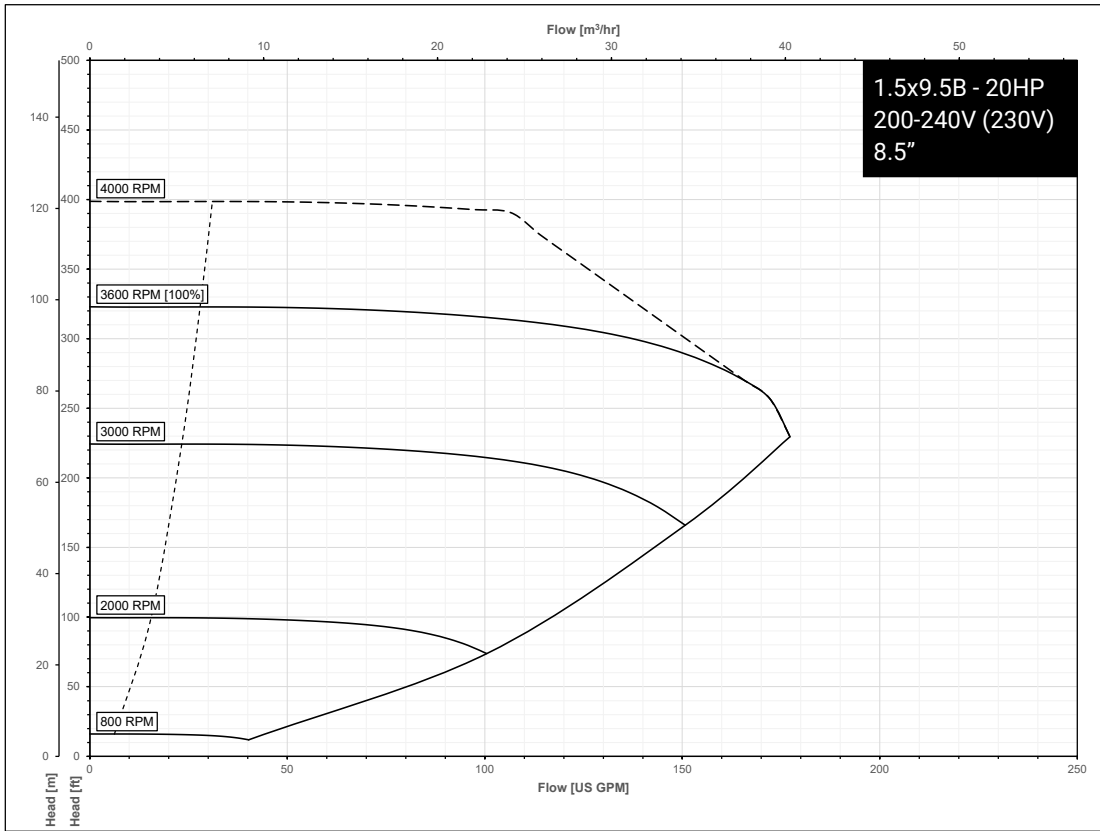

# Series e-80X Performance Curves for High Speed Models - 230V

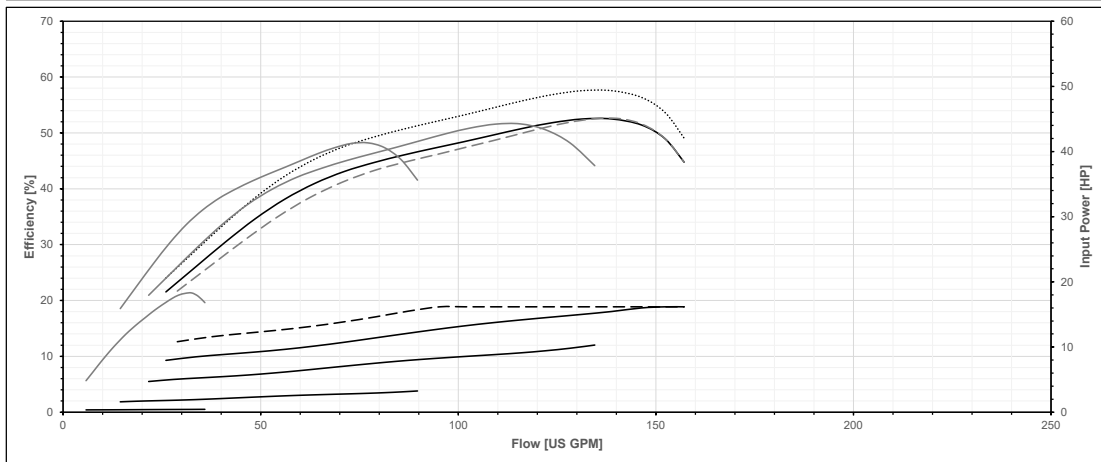
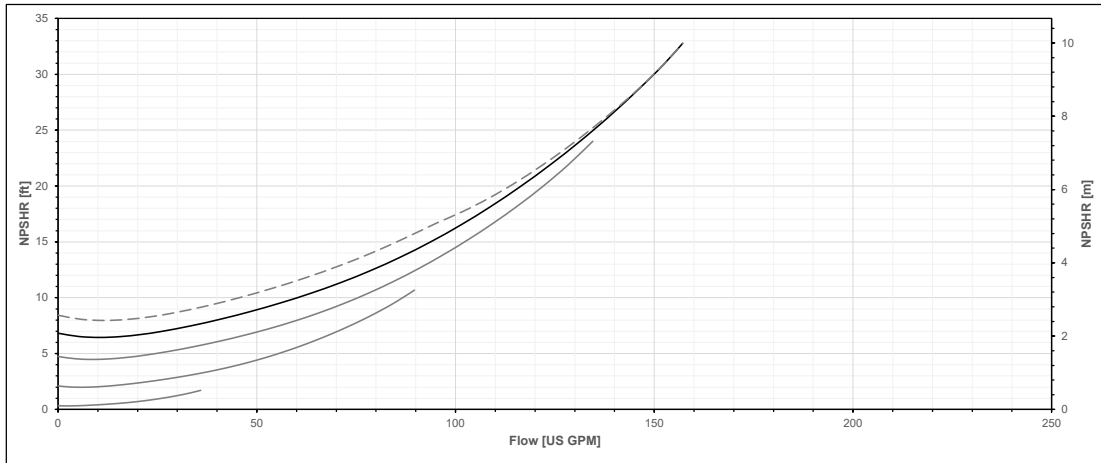
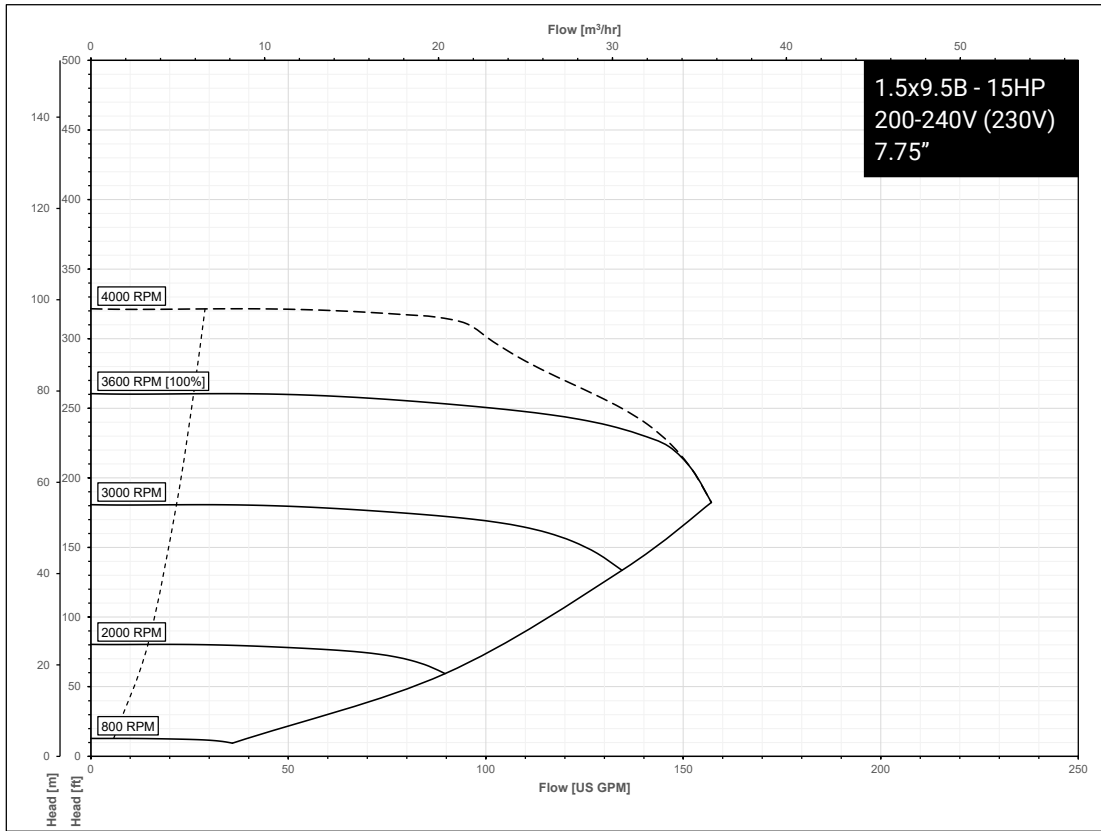

# Series e-80X Performance Curves for High Speed Models - 230V

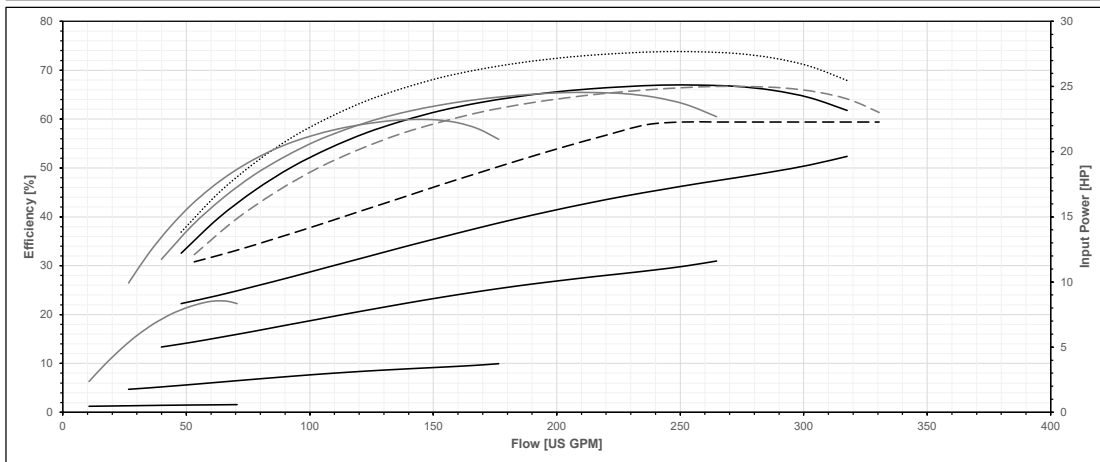
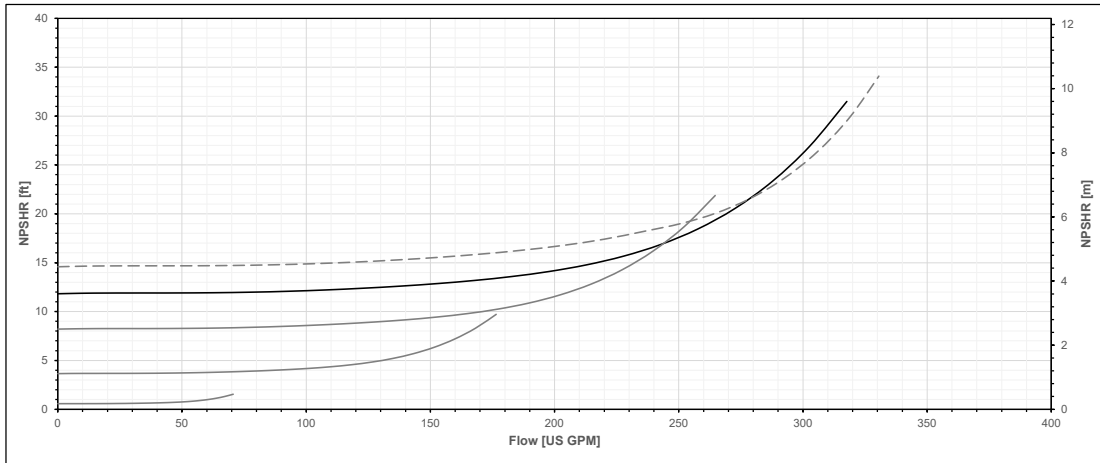
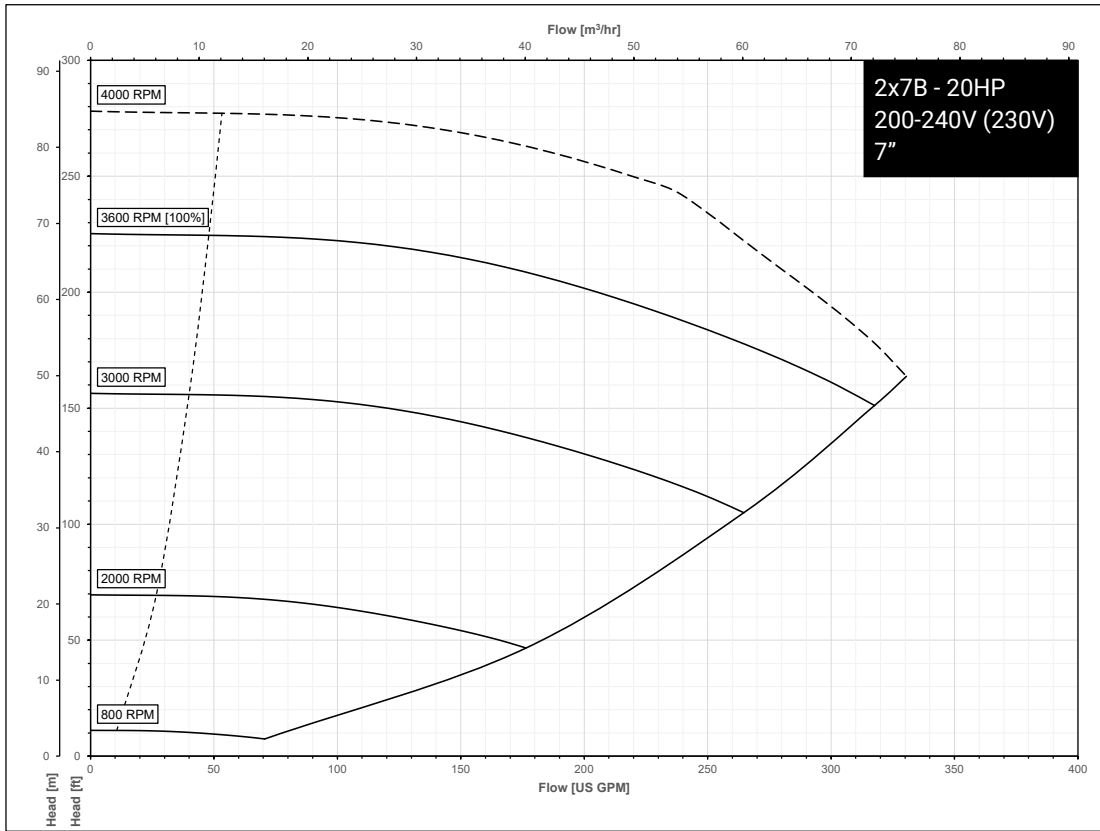

# Series e-80X Performance Curves for High Speed Models - 230V

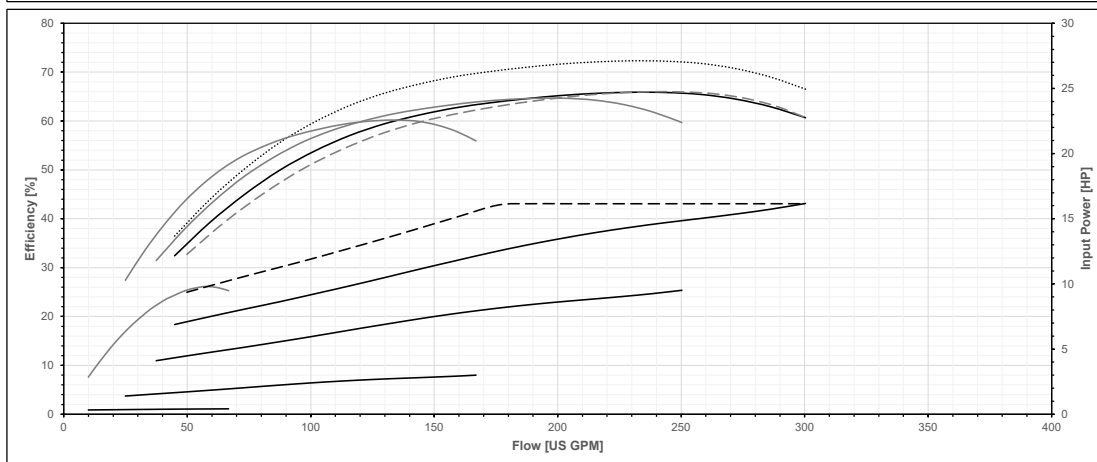
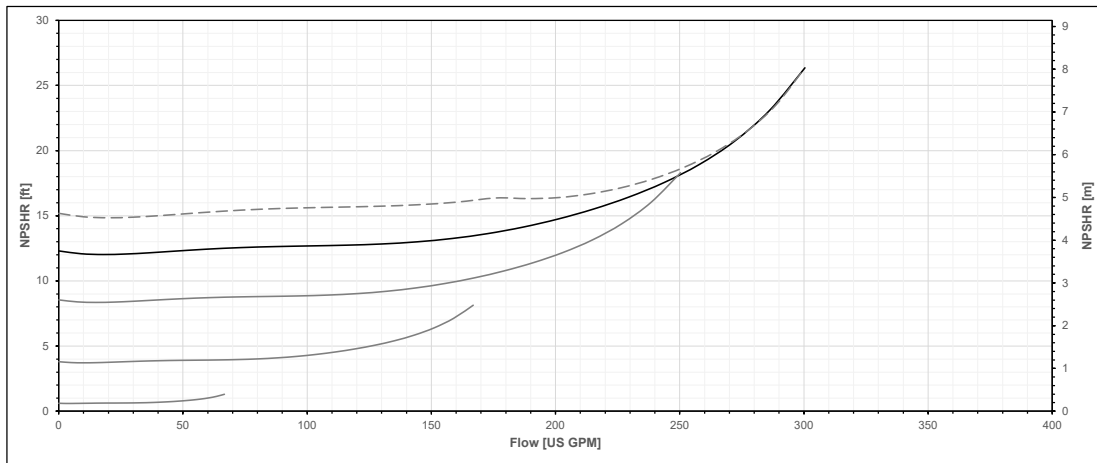
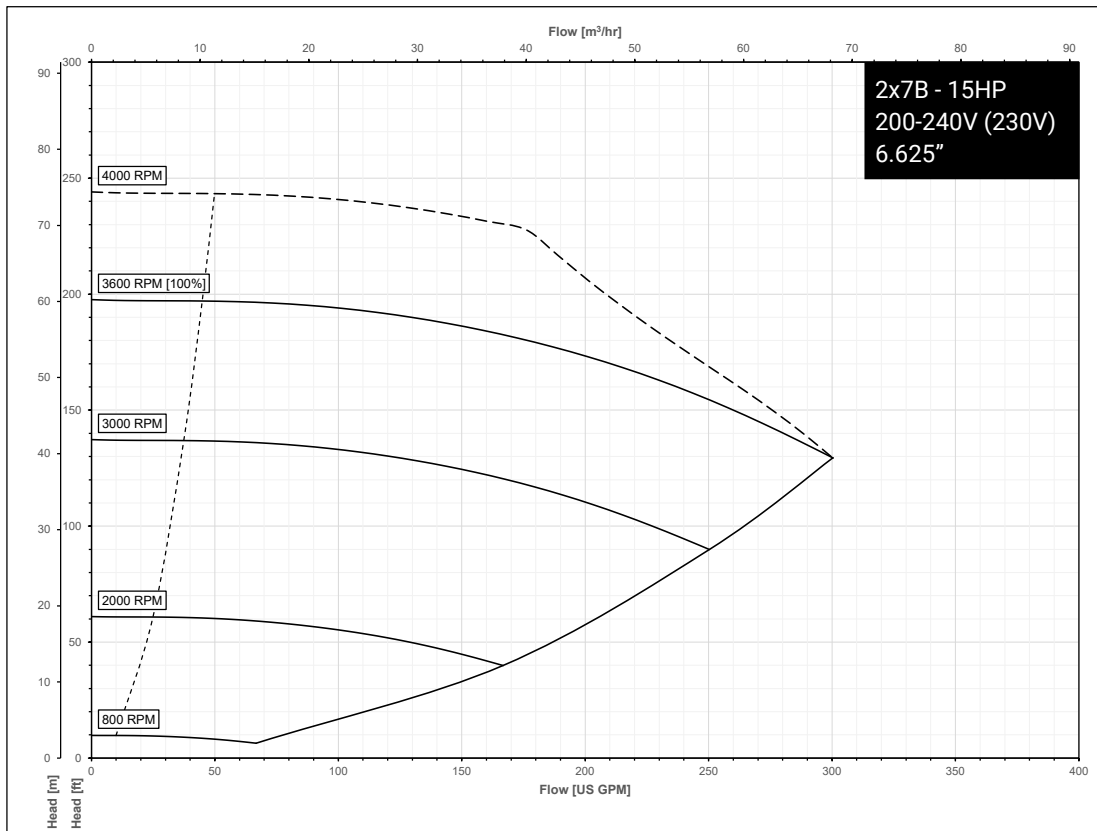

# Series e-80X Performance Curves for High Speed Models - 230V

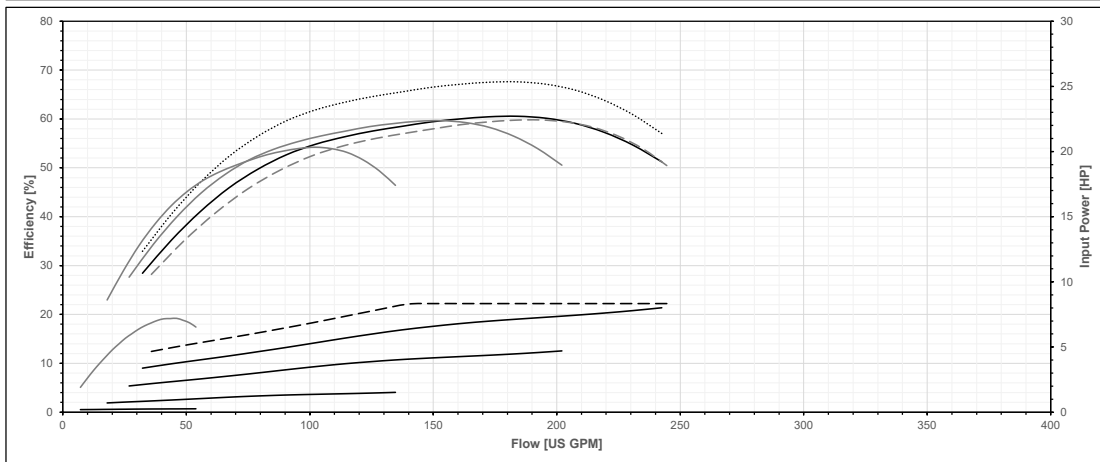
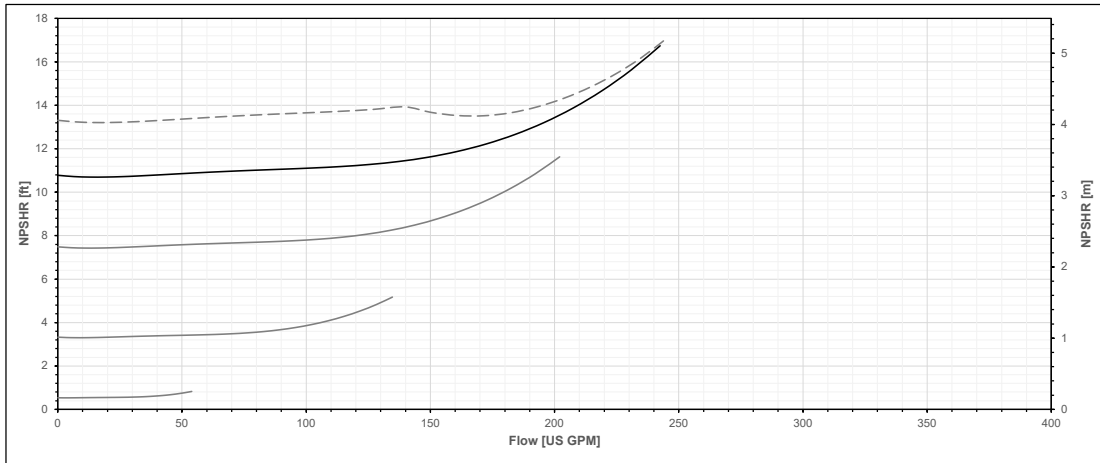
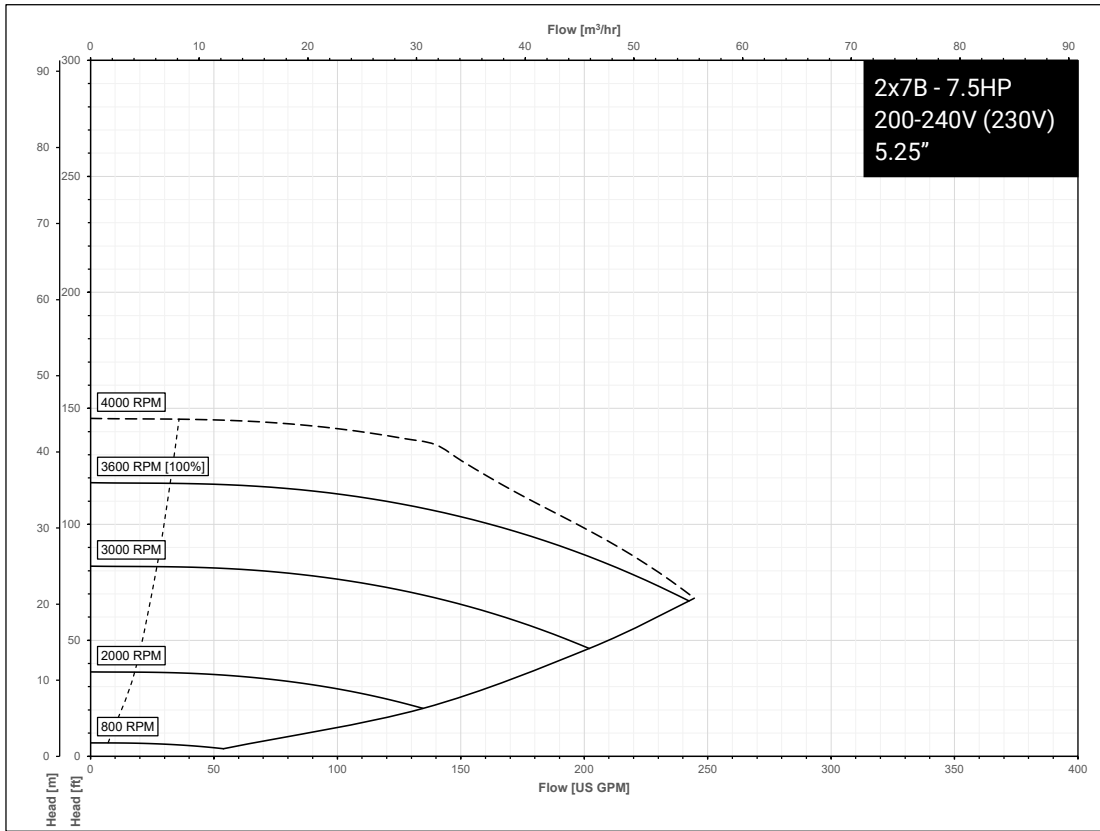

# Series e-80X Performance Curves for High Speed Models - 230V

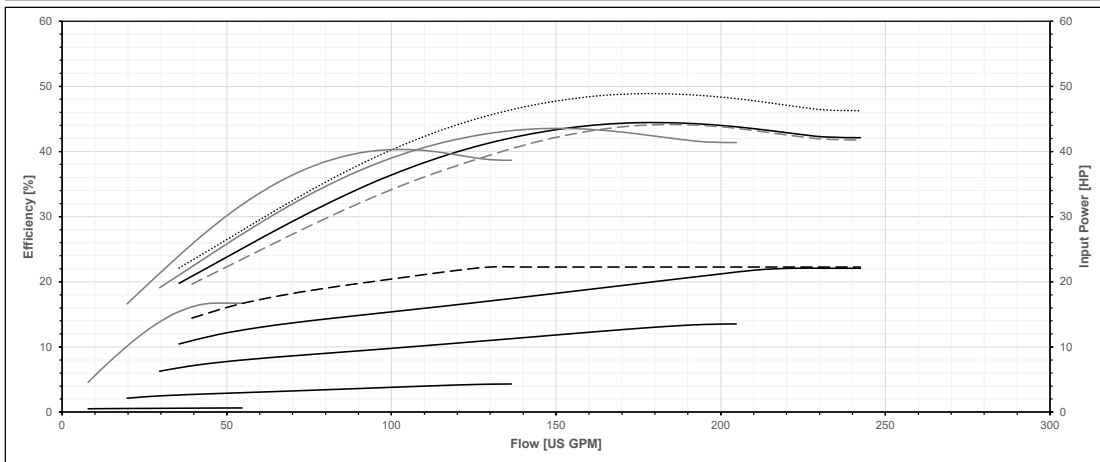
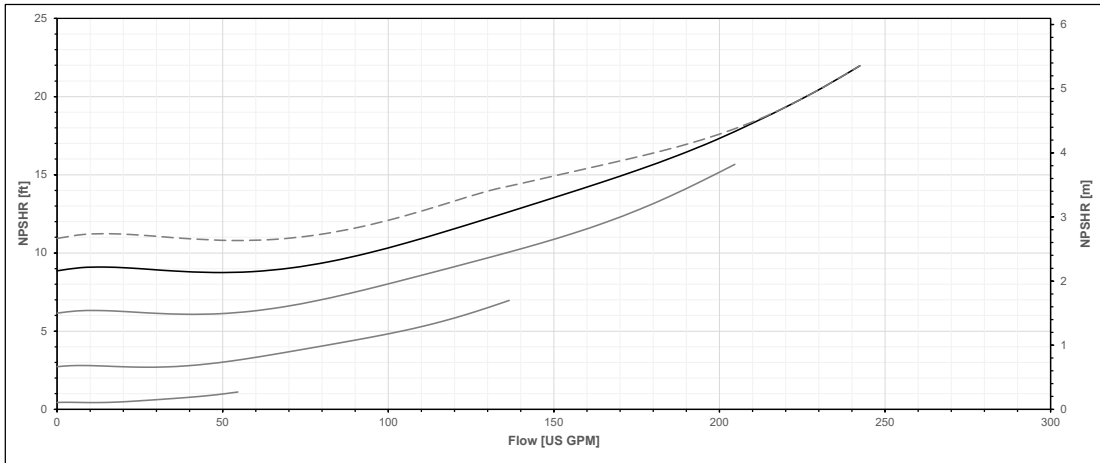
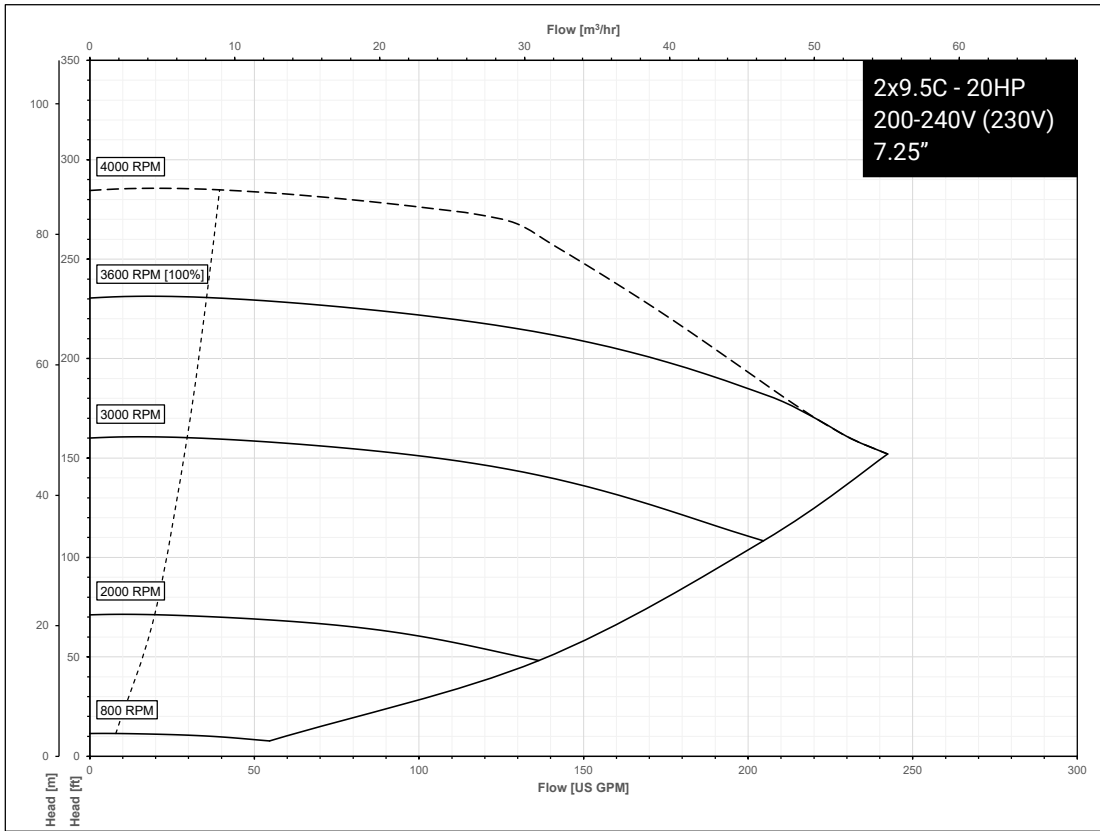

# Series e-80X Performance Curves for High Speed Models - 230V

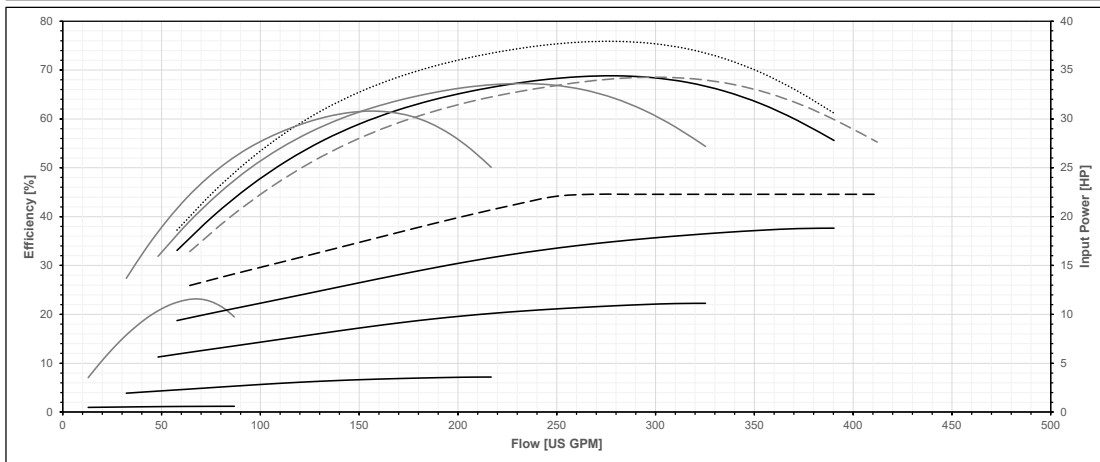
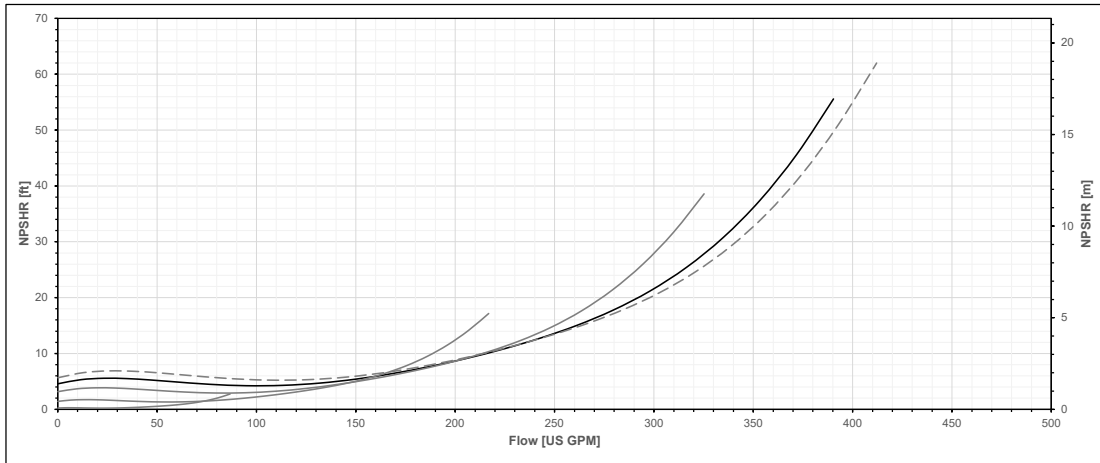
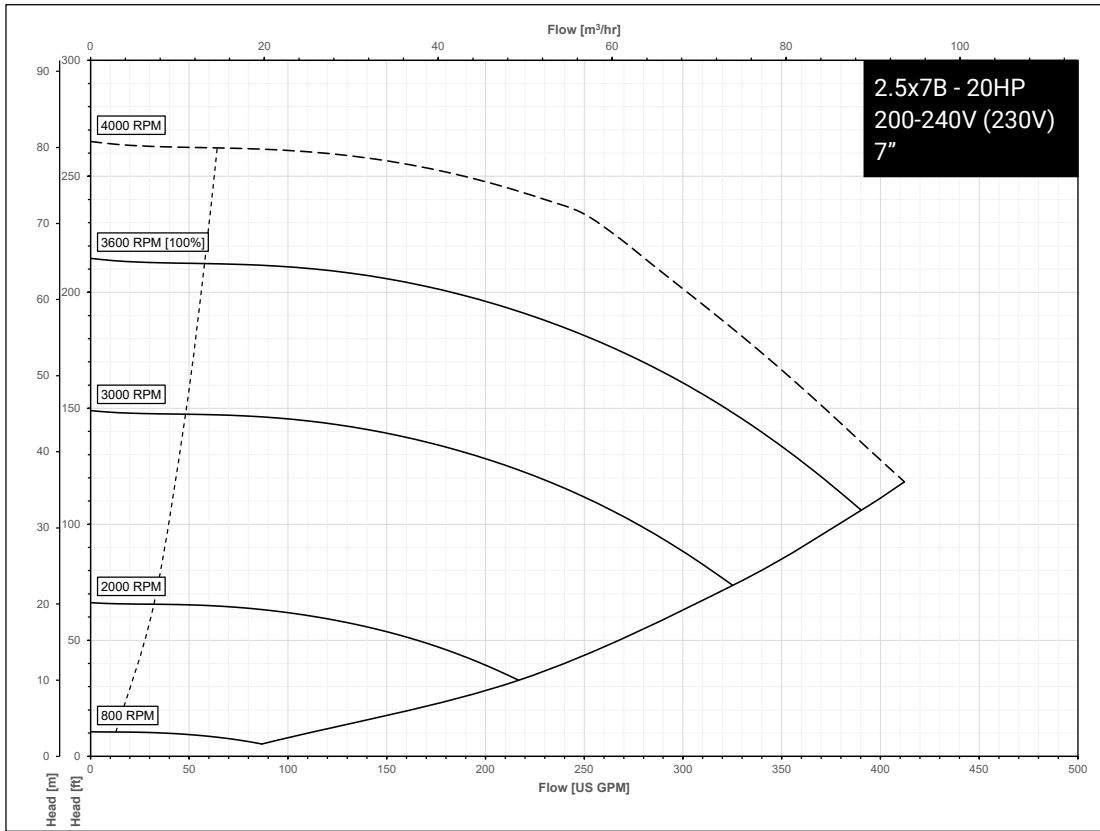

# Series e-80X Performance Curves for High Speed Models - 230V

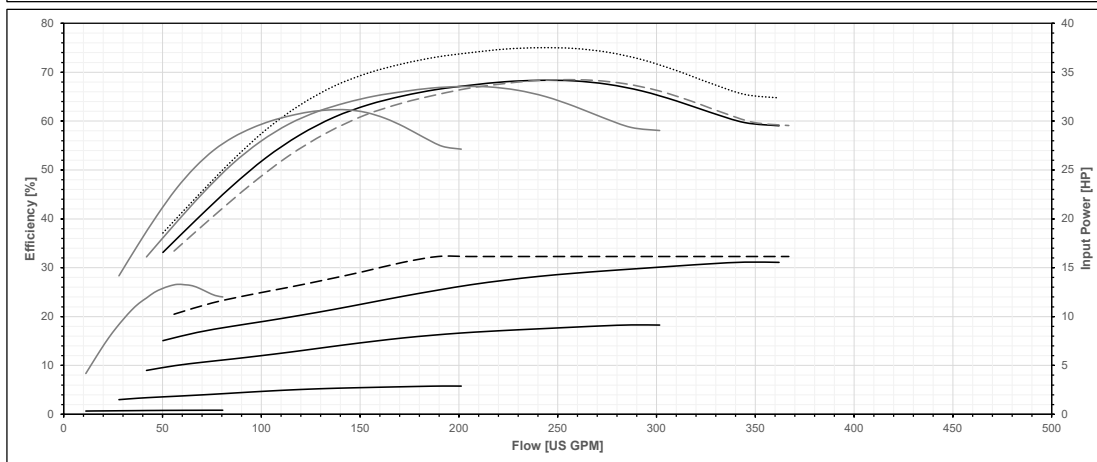
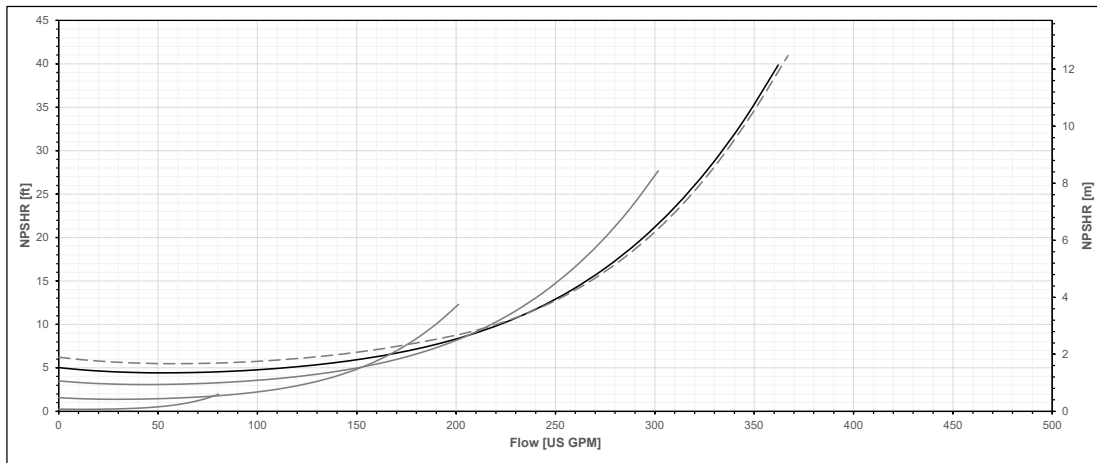
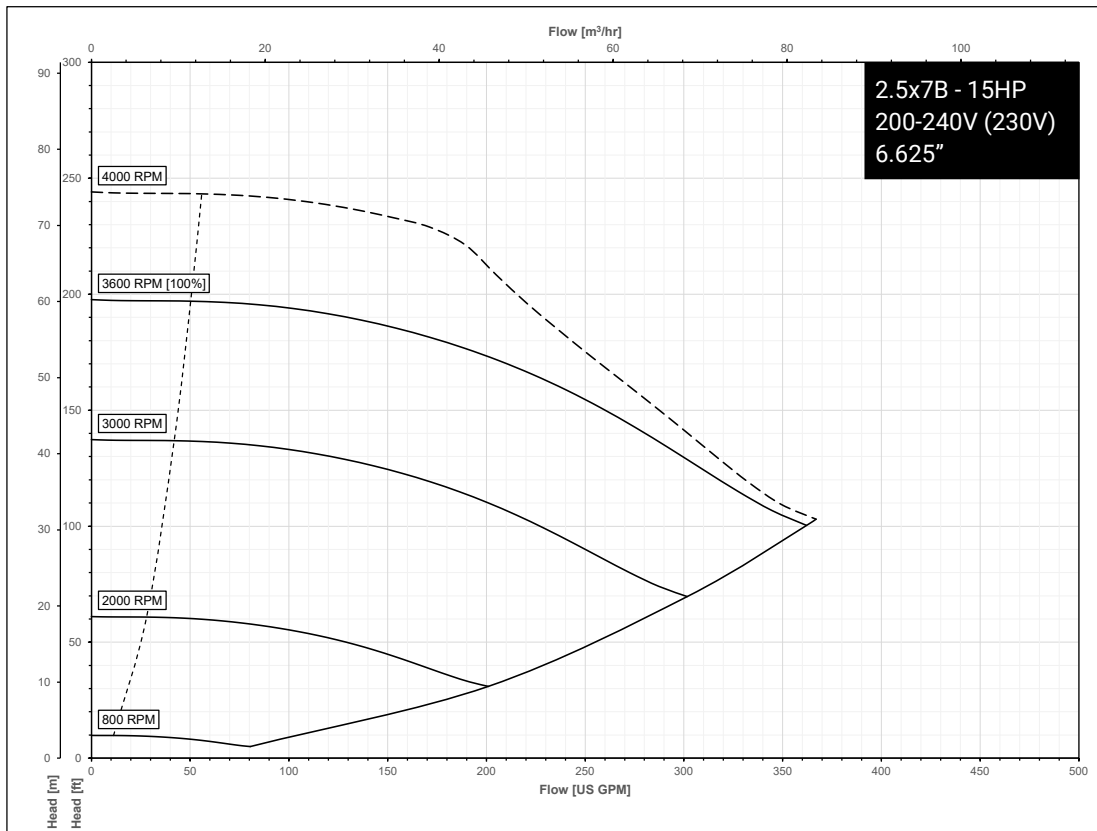

# Series e-80X Performance Curves for High Speed Models - 230V

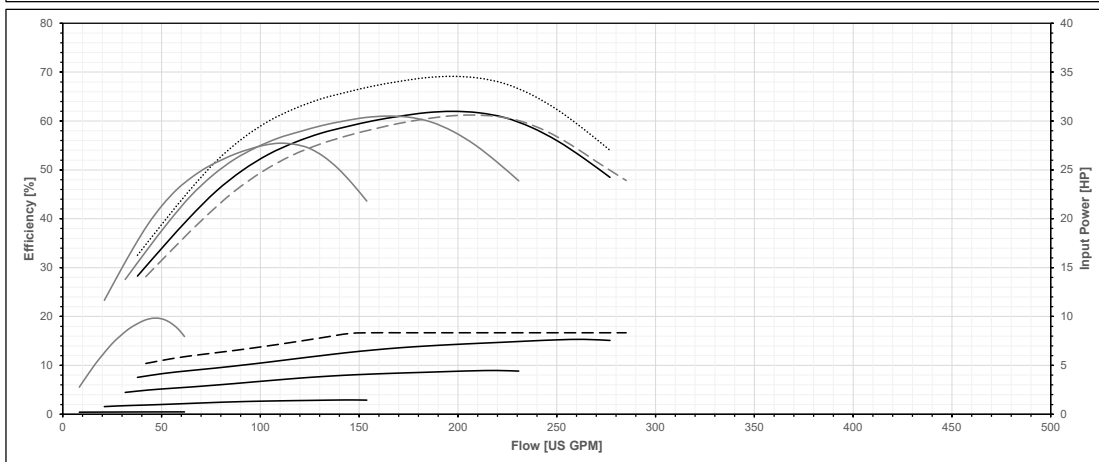
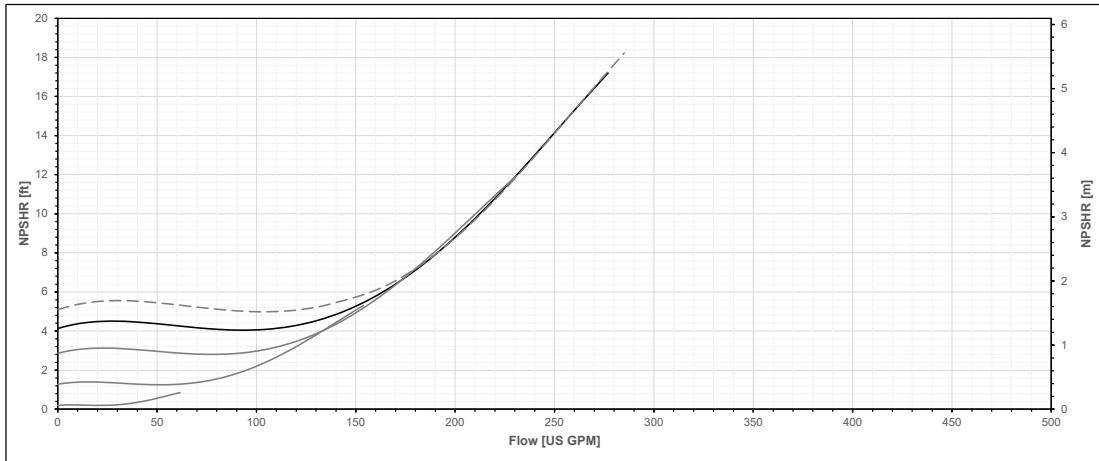
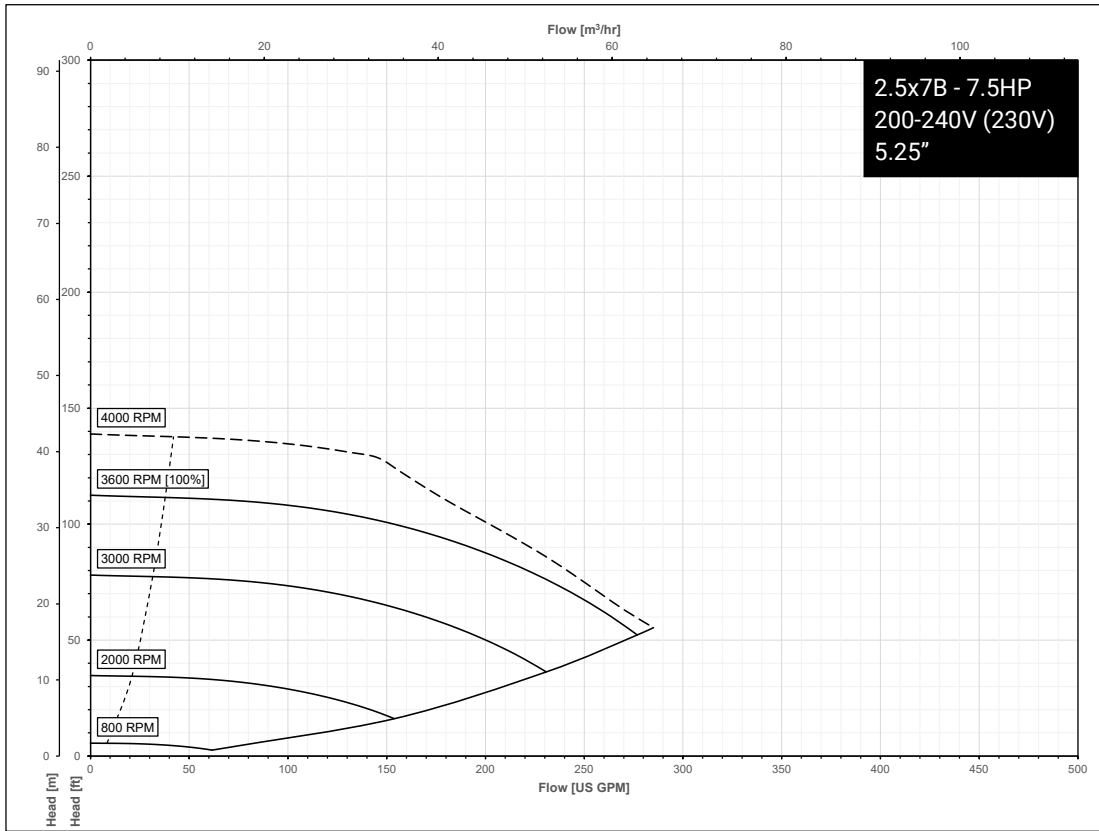

# Series e-80X Performance Curves for High Speed Models - 230V

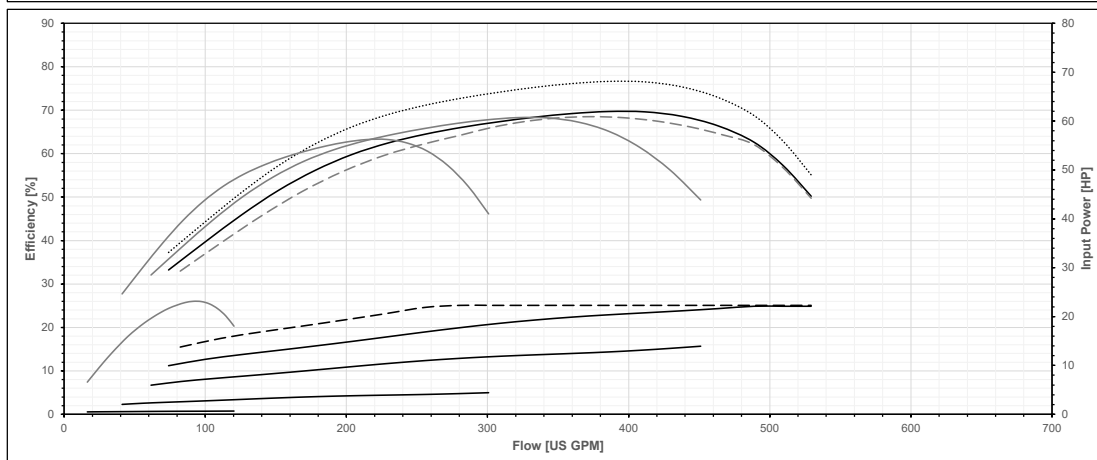
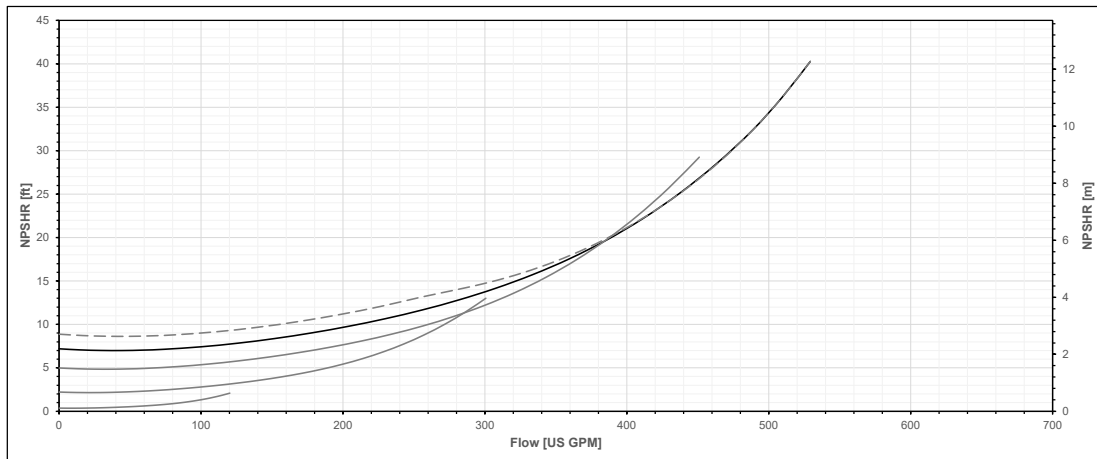
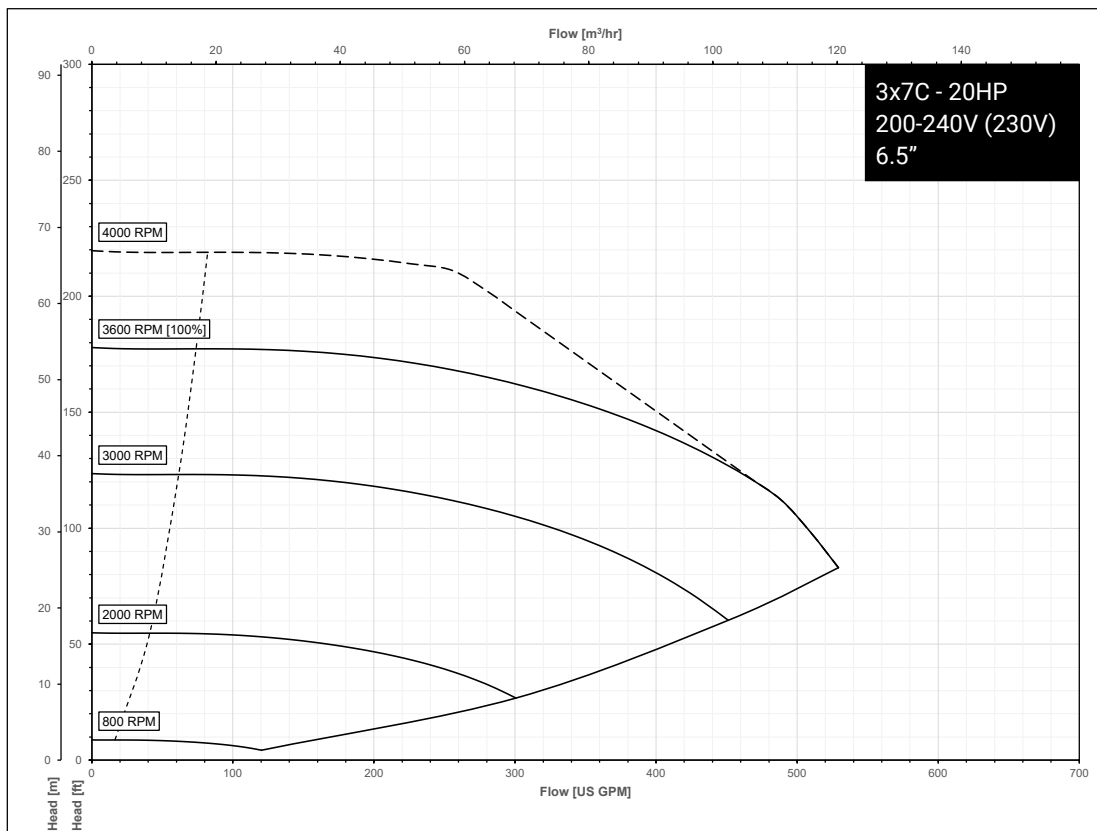

# Series e-80X Performance Curves for High Speed Models - 460V

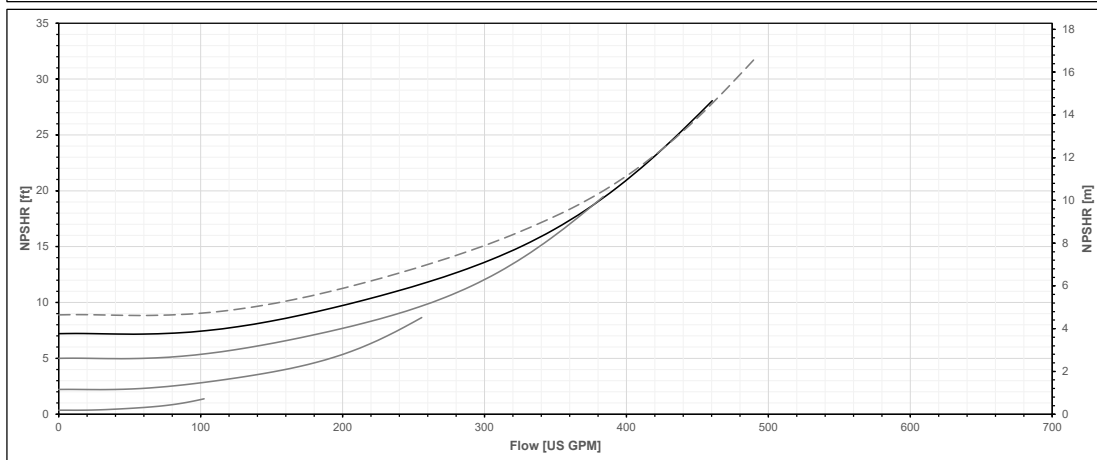
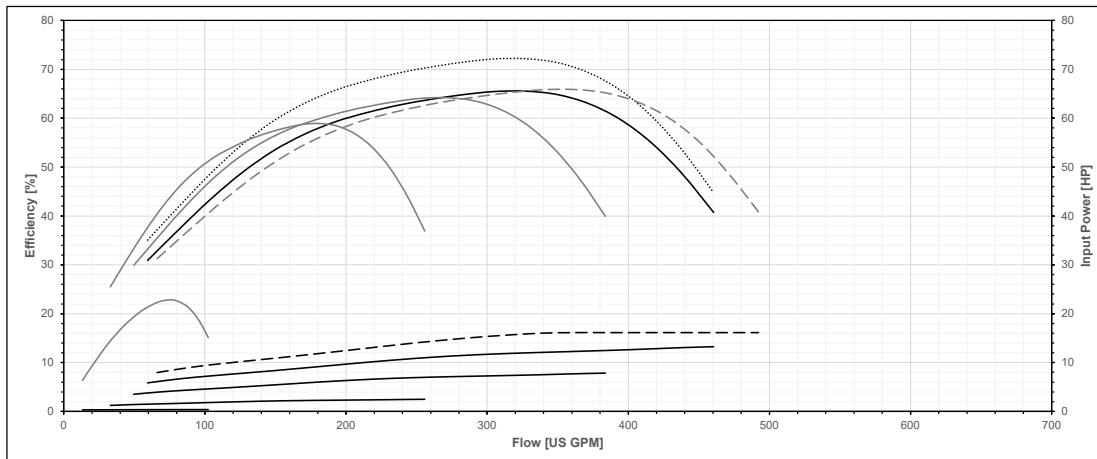
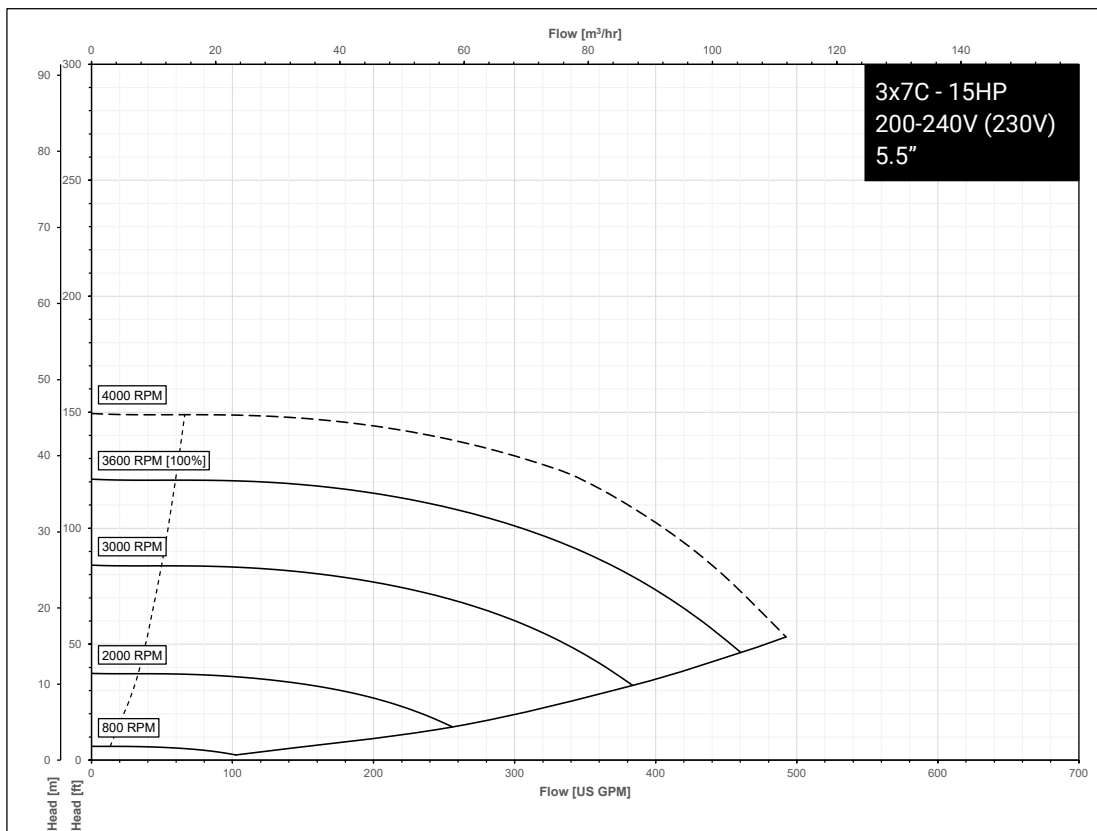

# Series e-80X Performance Curves for High Speed Models - 230V

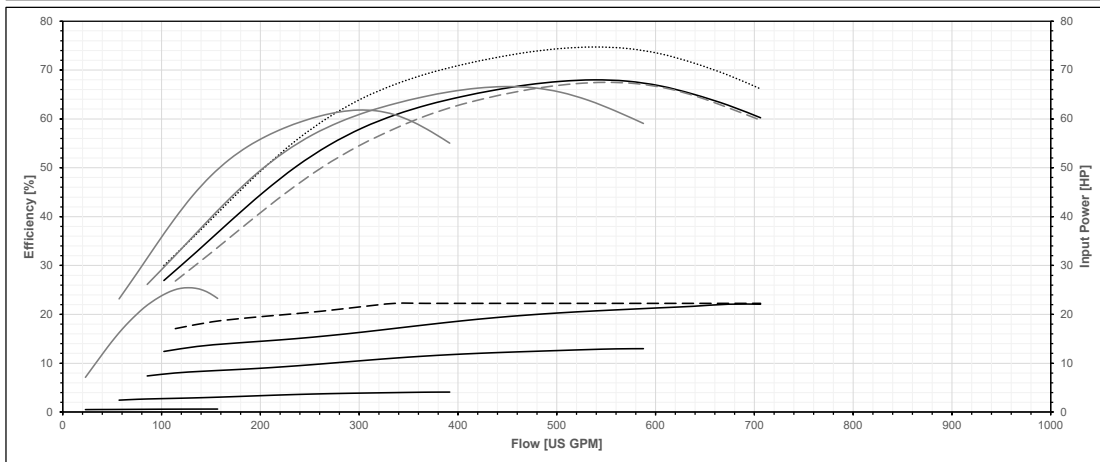
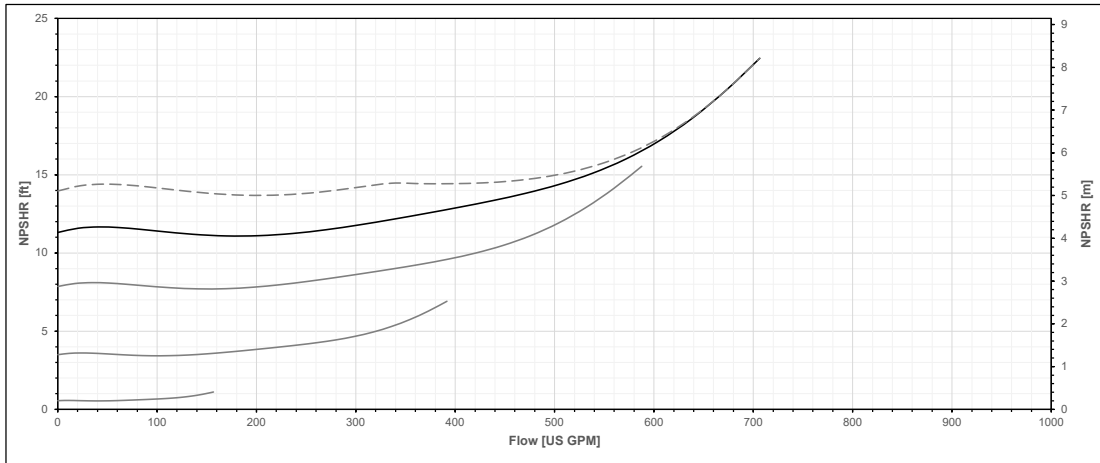
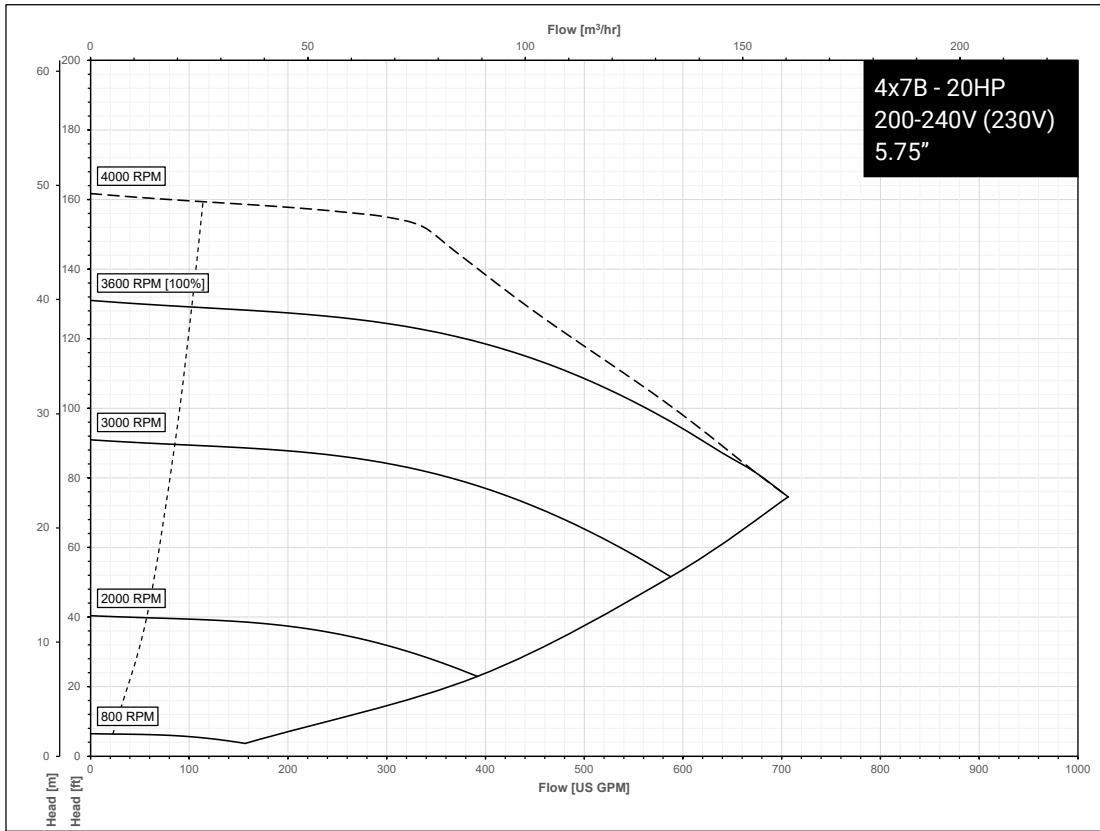

# Series e-80X Performance Curves for High Speed Models - 230V

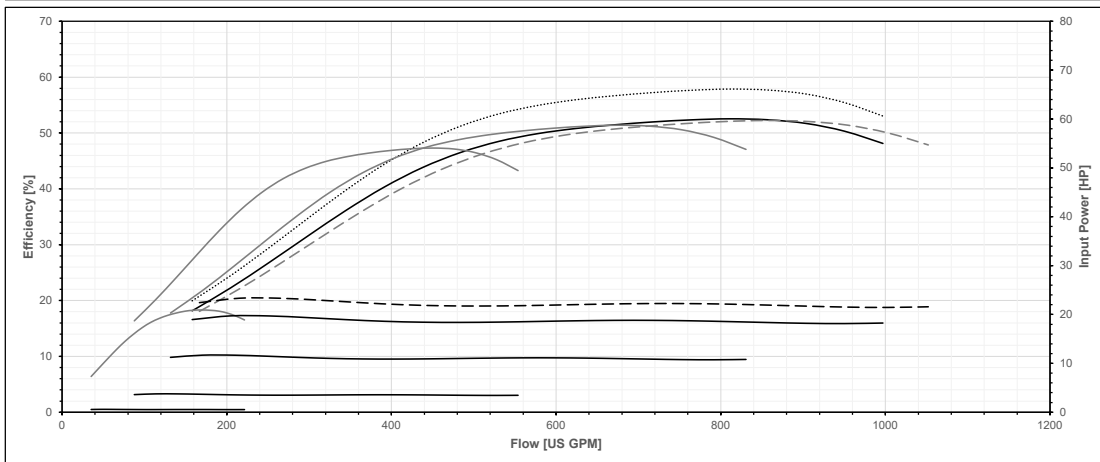
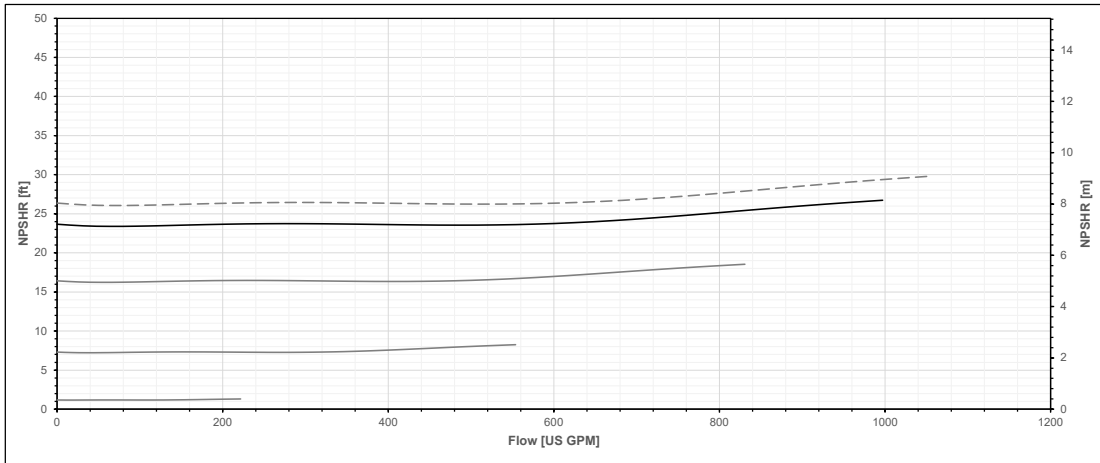
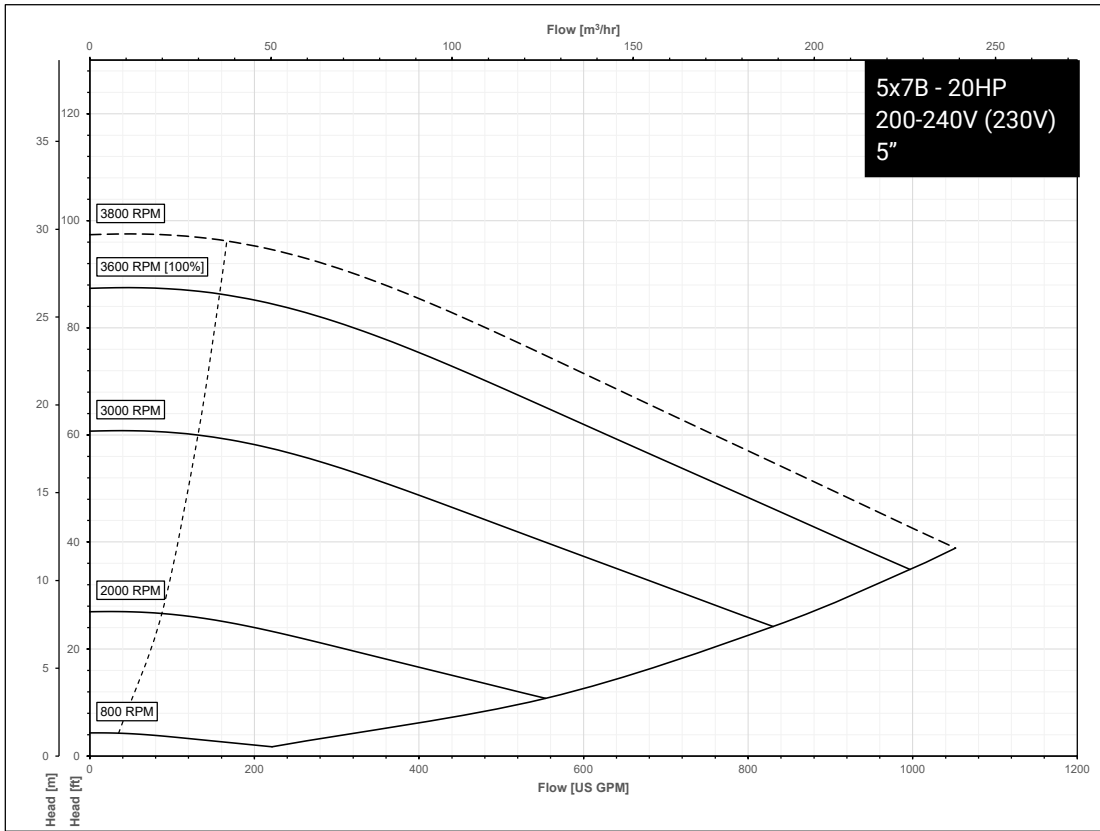

# SERIES e-80X Performance Curves for Low Speed Models

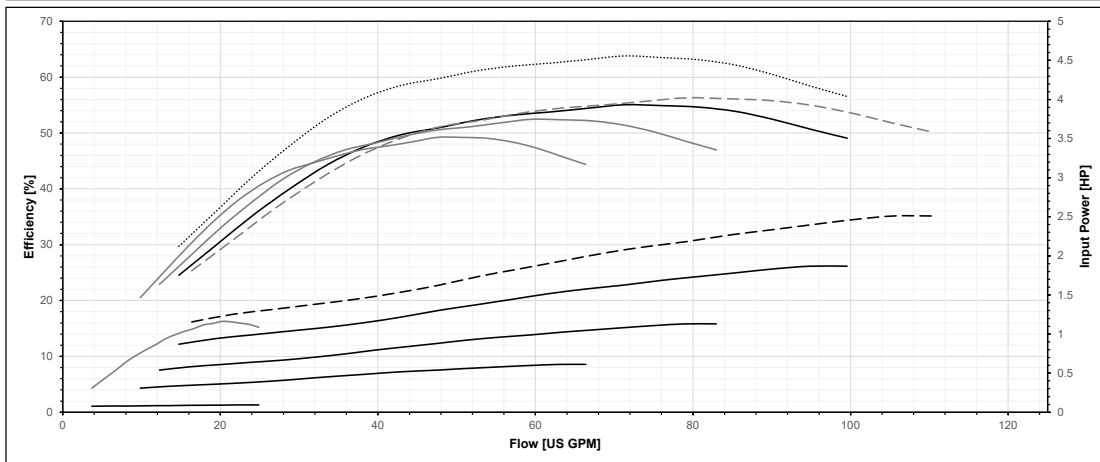
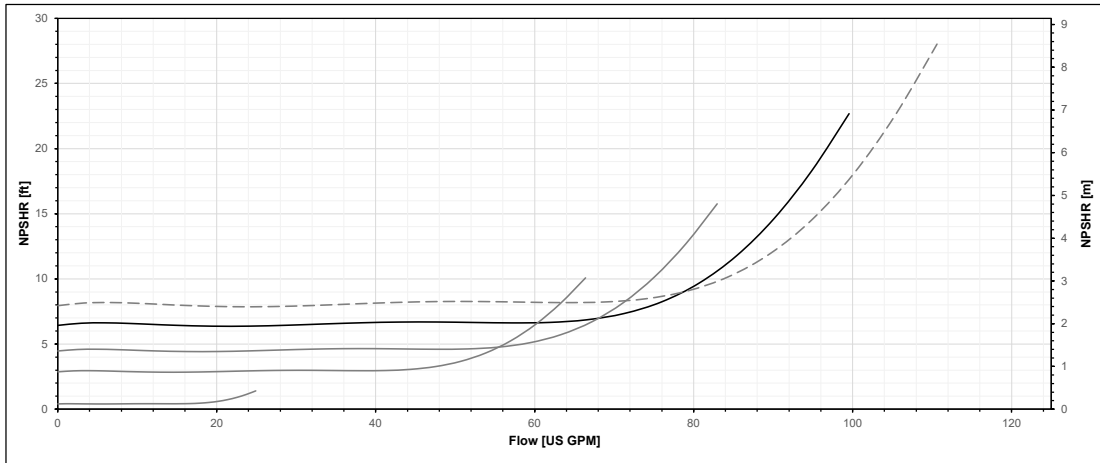
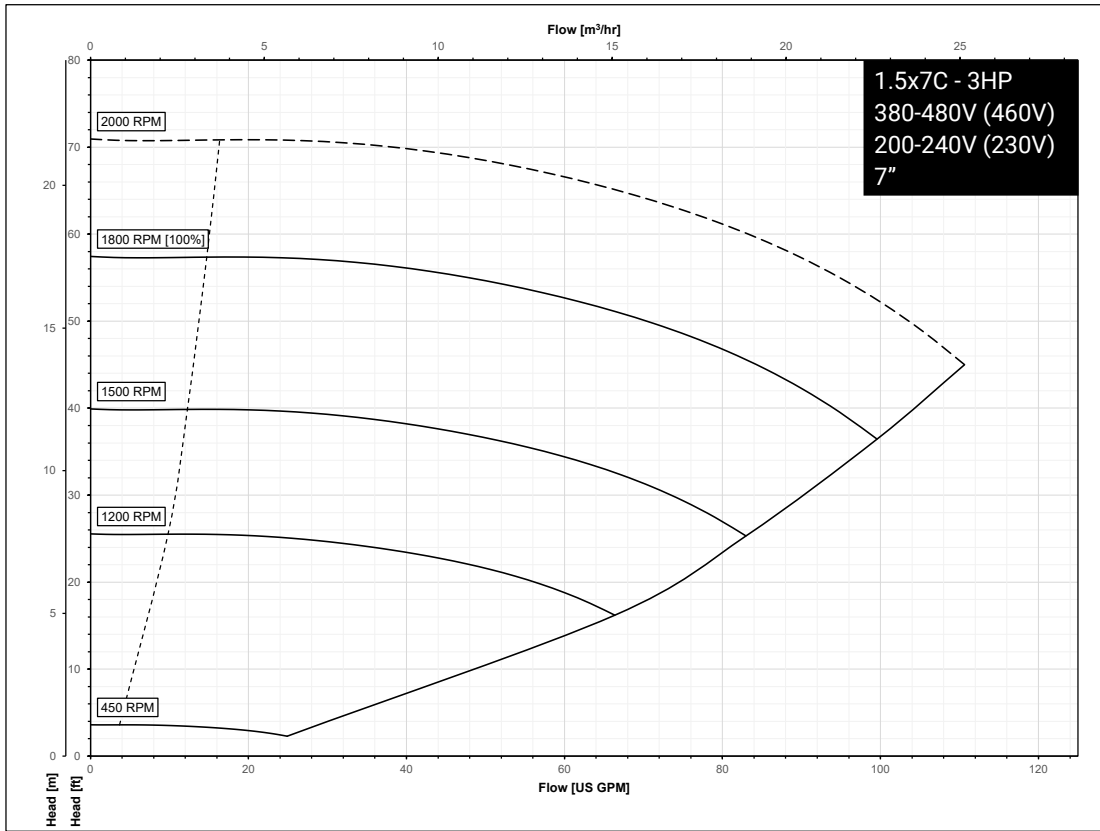

# SERIES e-80X Performance Curves for Low Speed Models

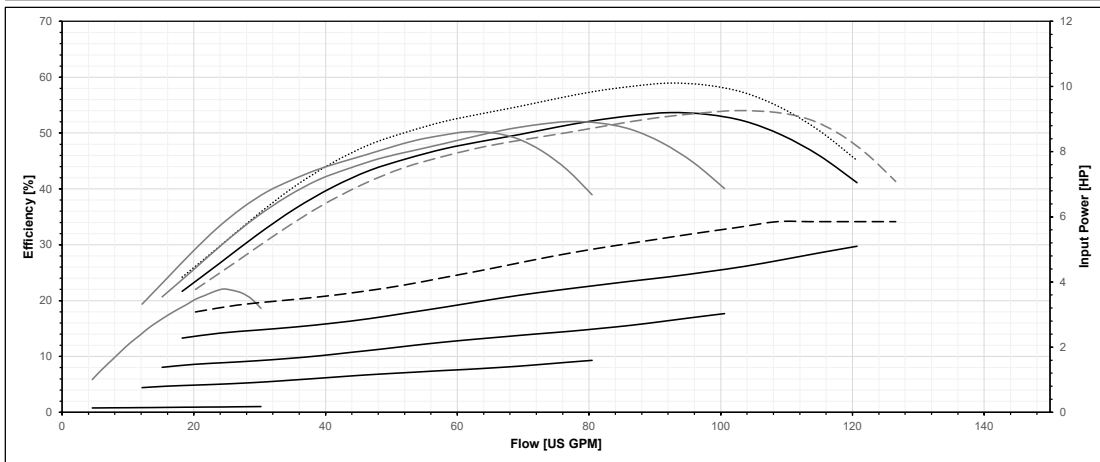
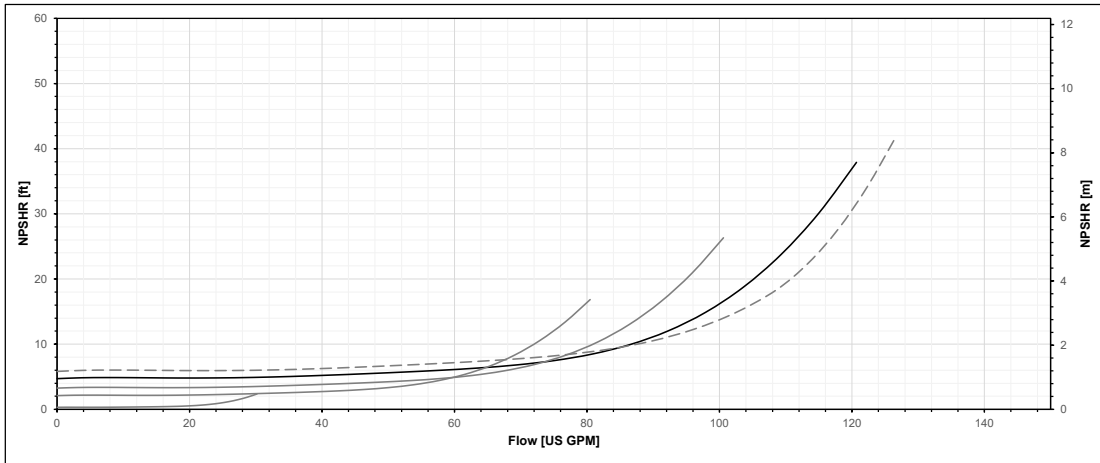
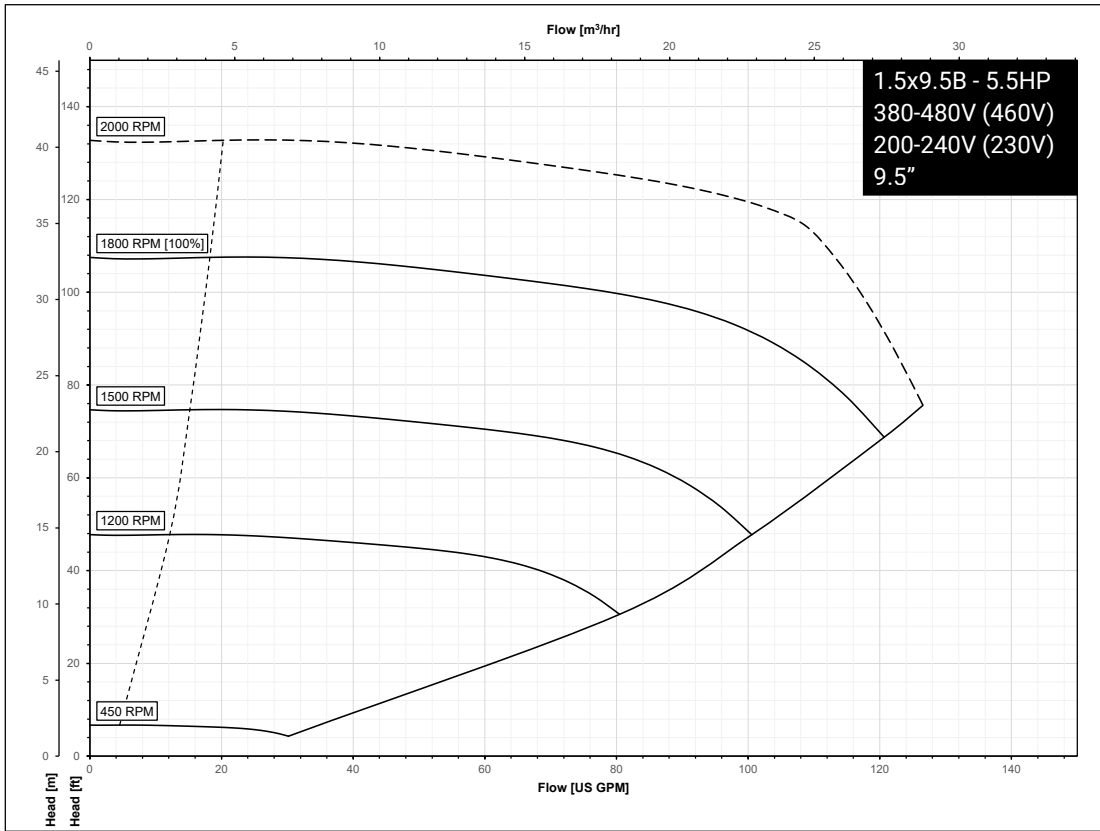

# SERIES e-80X Performance Curves for Low Speed Models

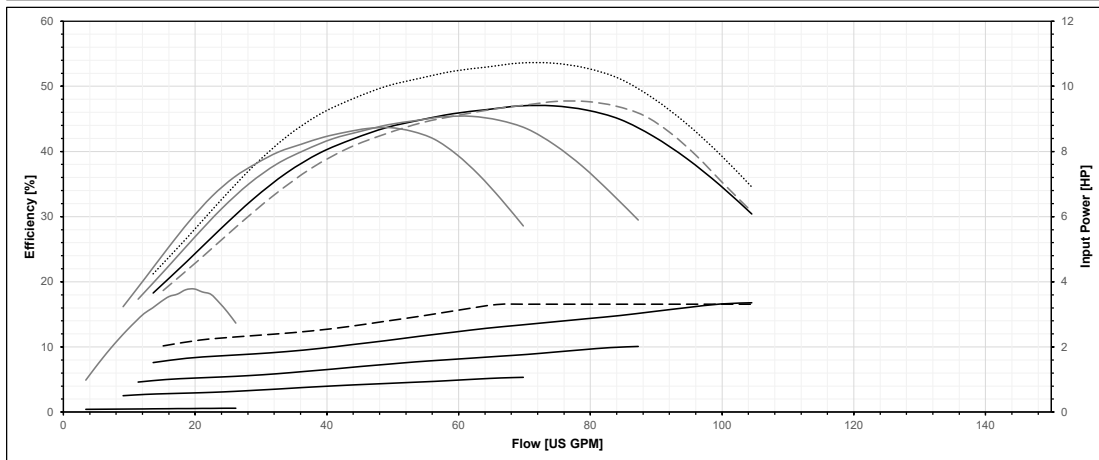
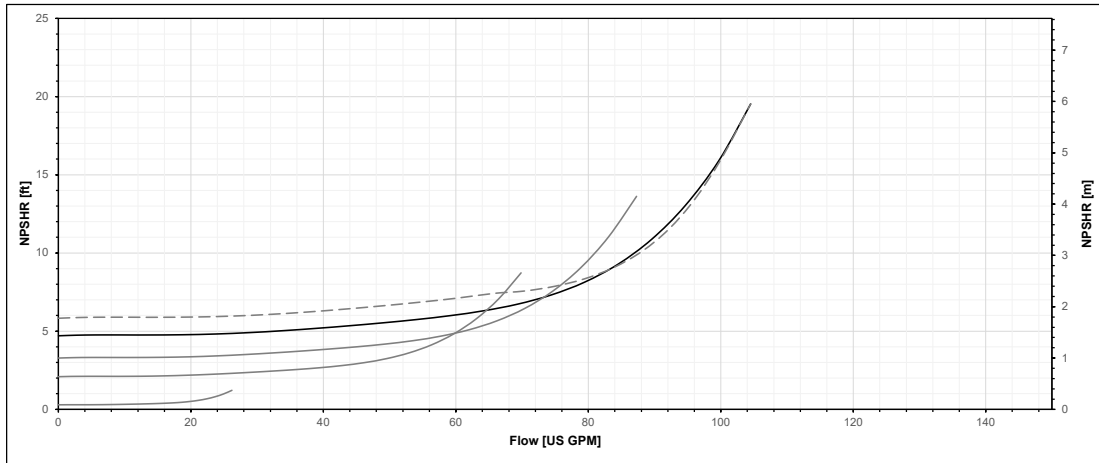
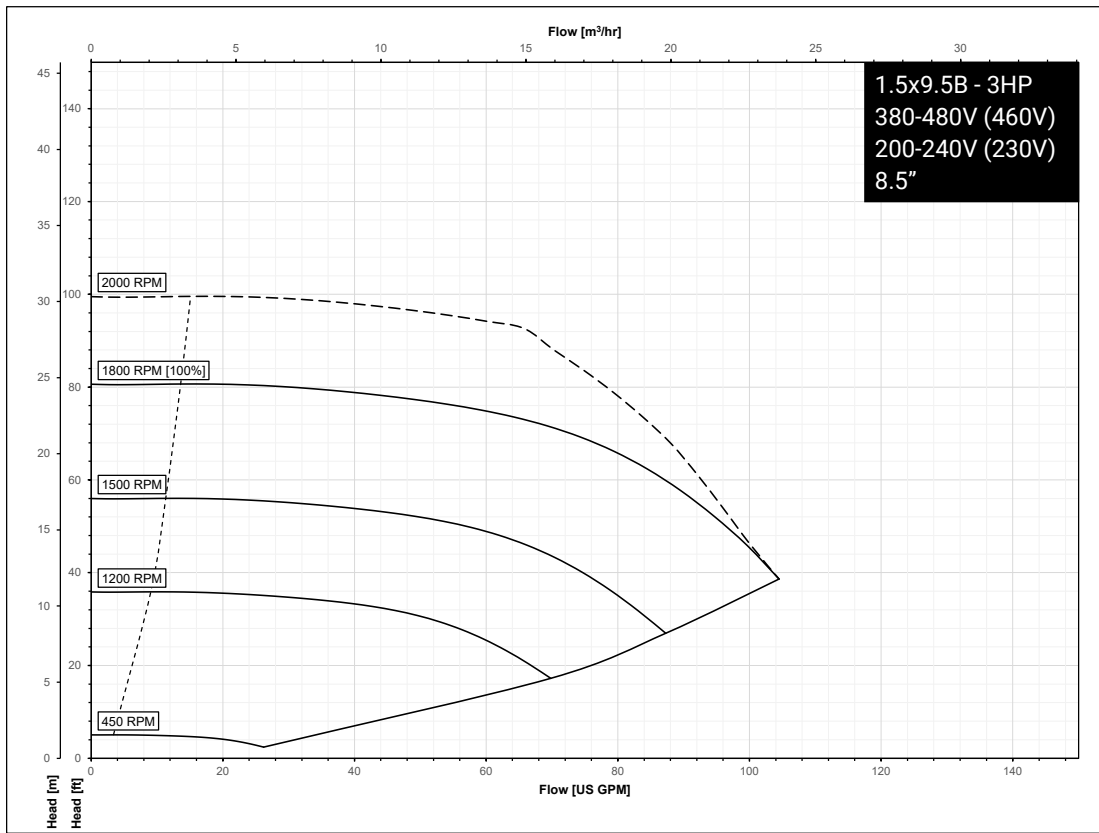

# SERIES e-80X Performance Curves for Low Speed Models

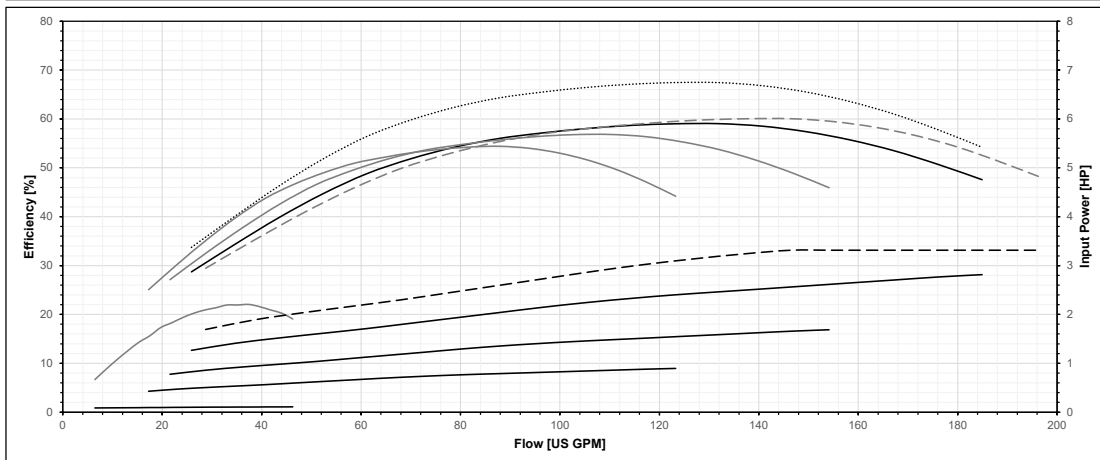
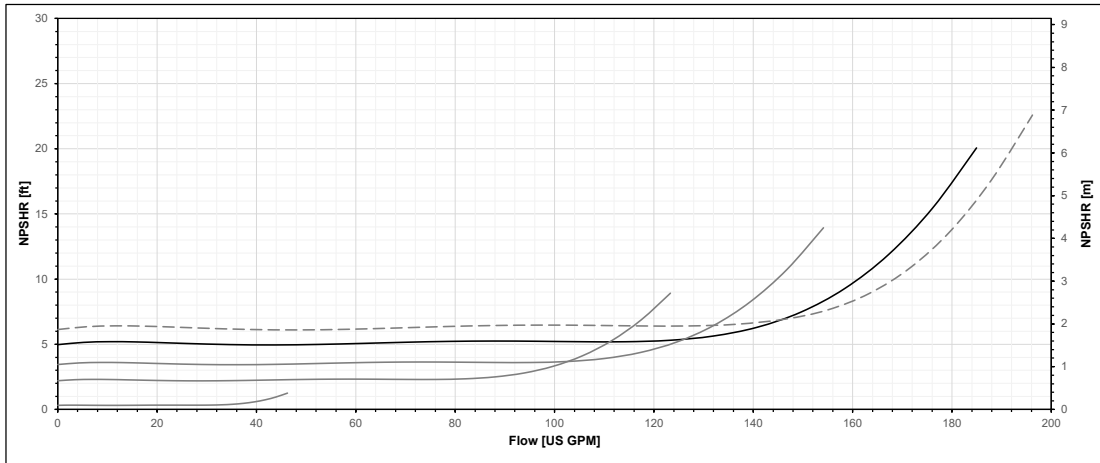
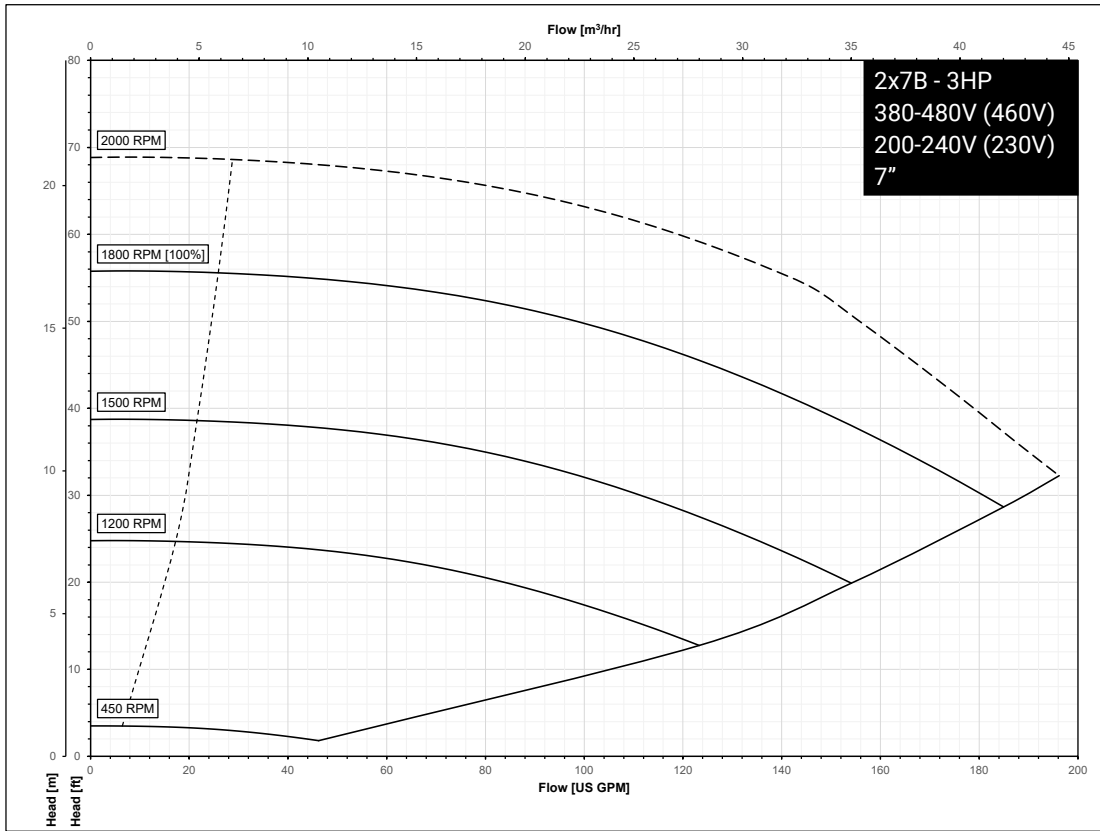

# SERIES e-80X Performance Curves for Low Speed Models

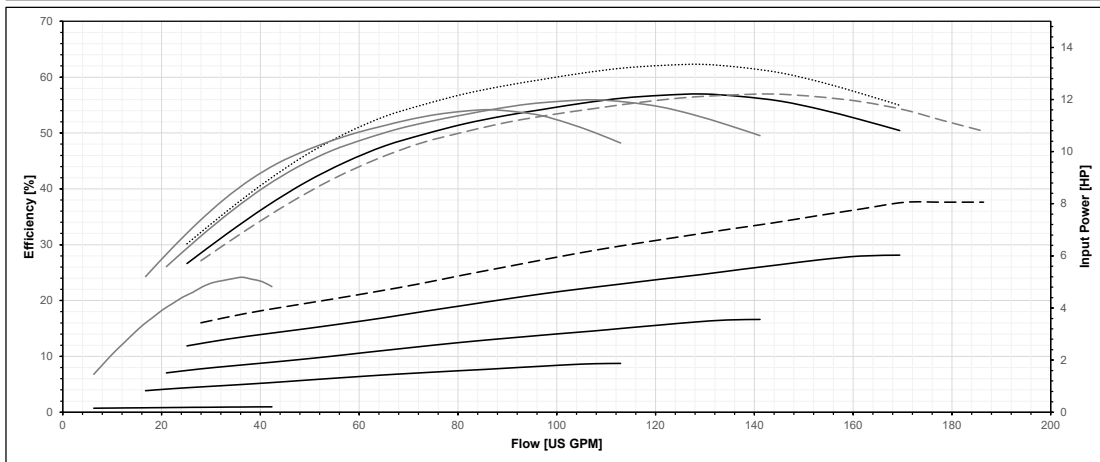
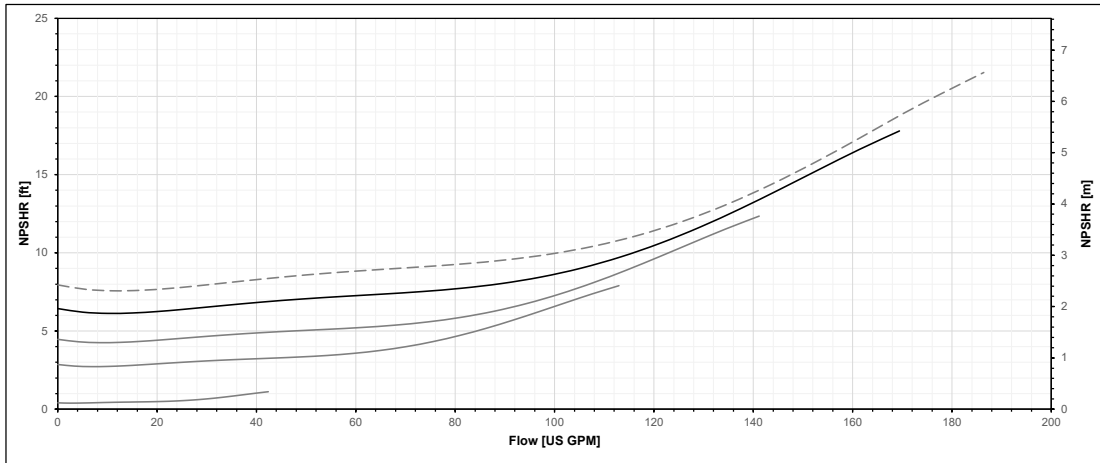
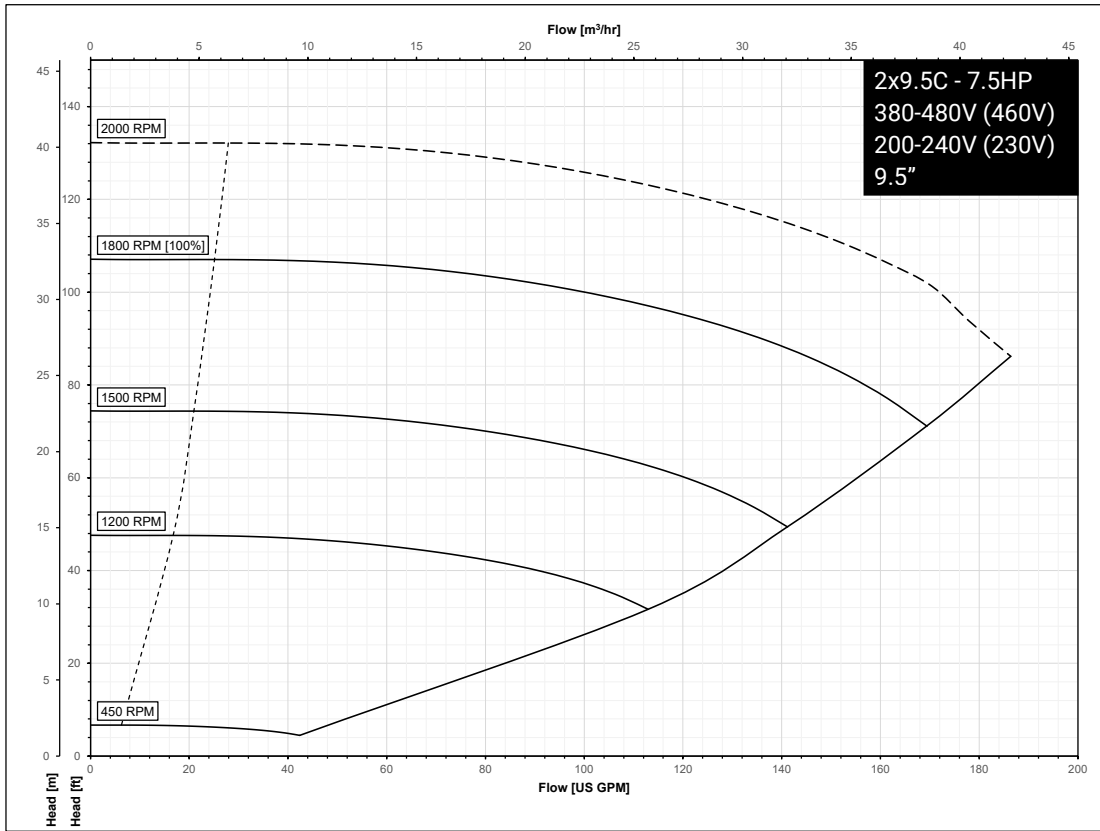

# SERIES e-80X Performance Curves for Low Speed Models

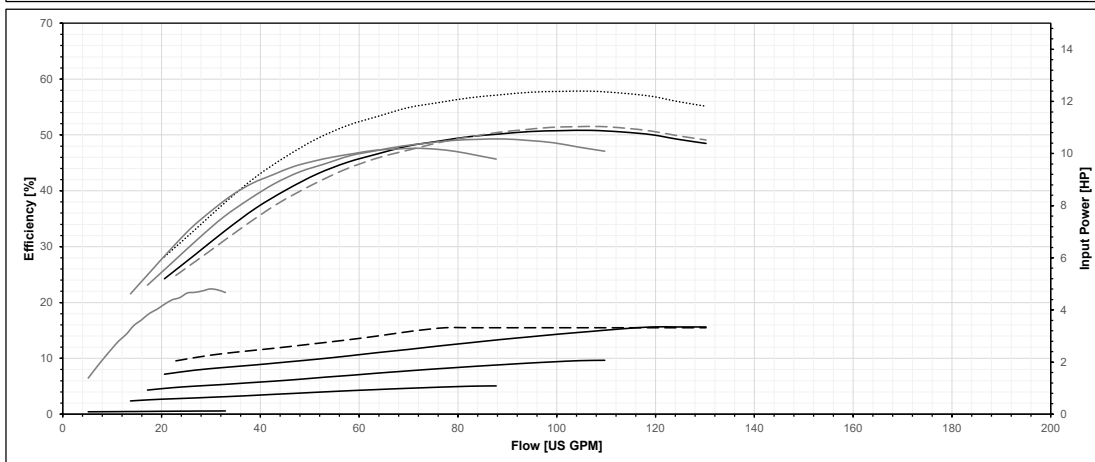
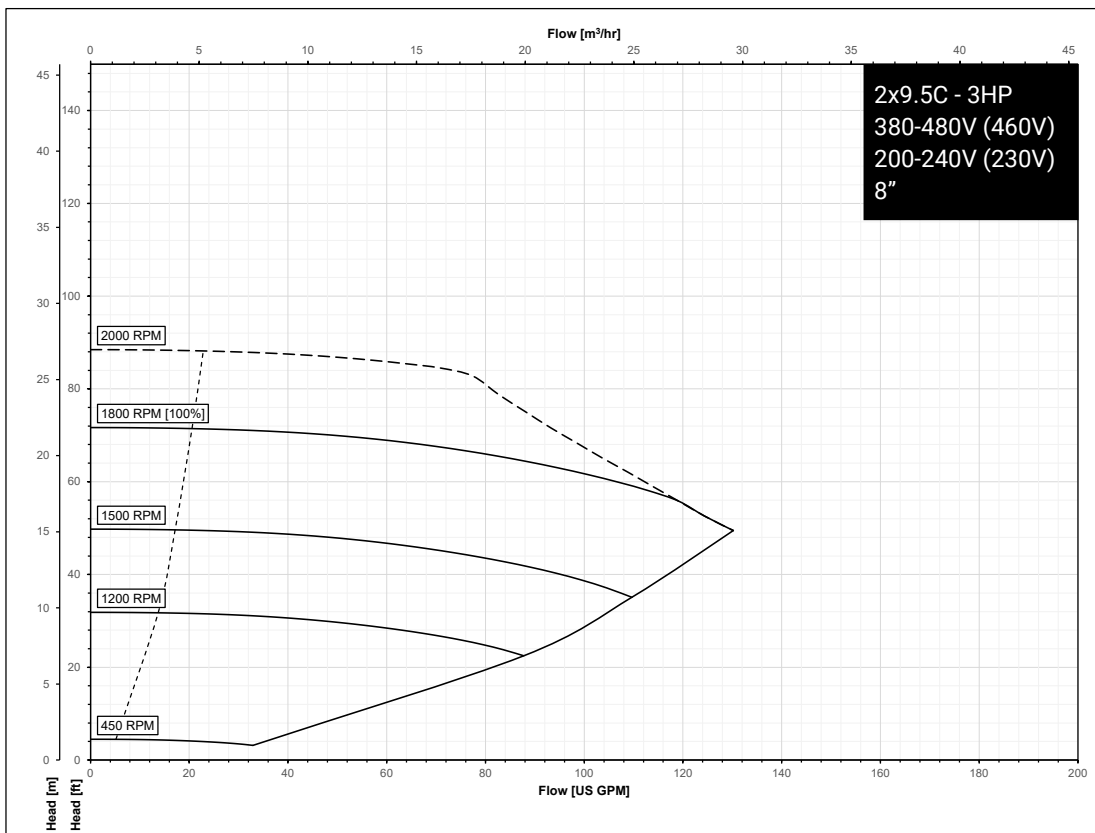

# SERIES e-80X Performance Curves for Low Speed Models

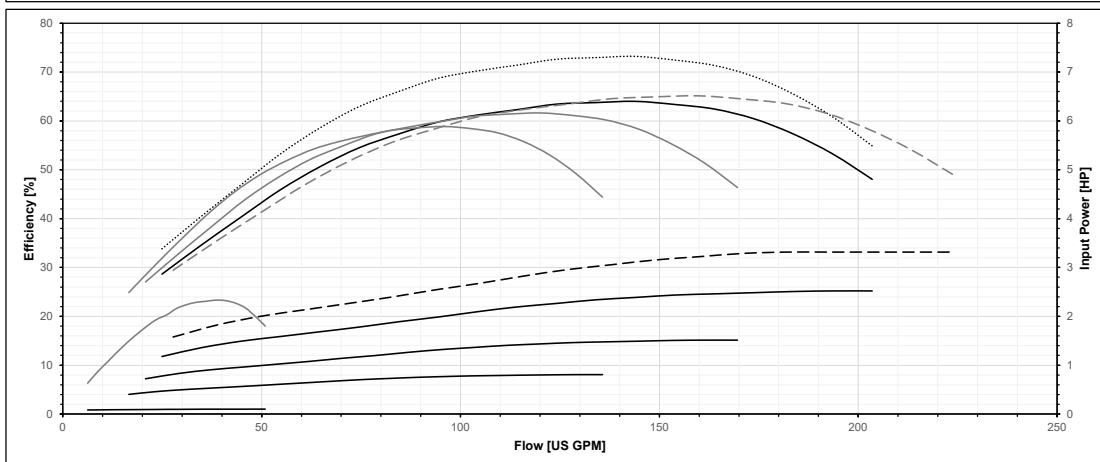
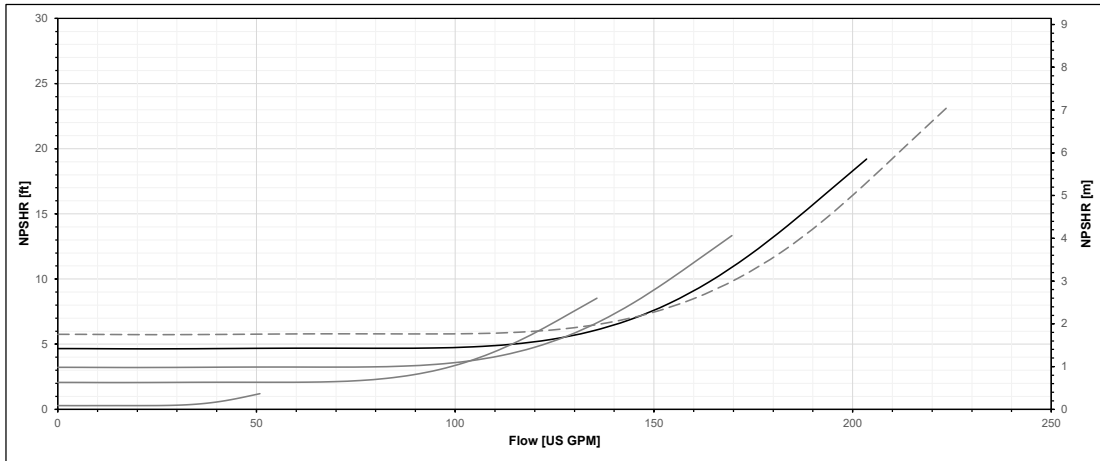
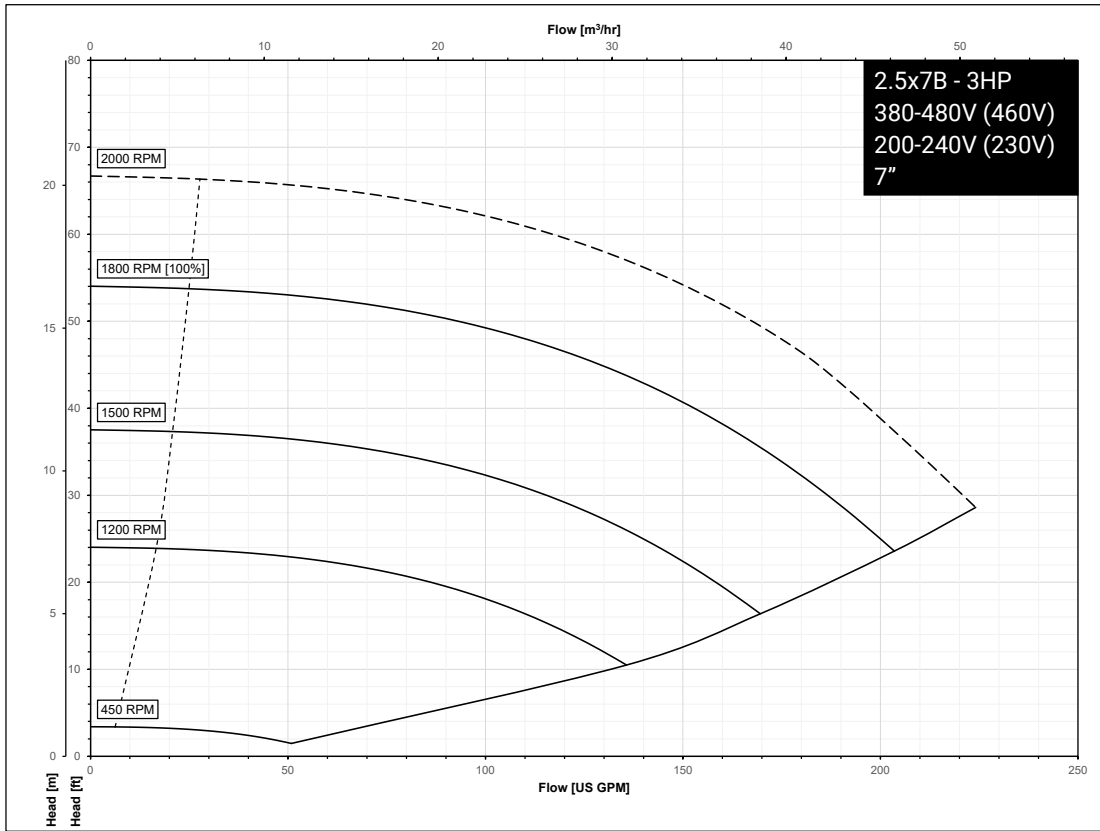

# SERIES e-80X Performance Curves for Low Speed Models

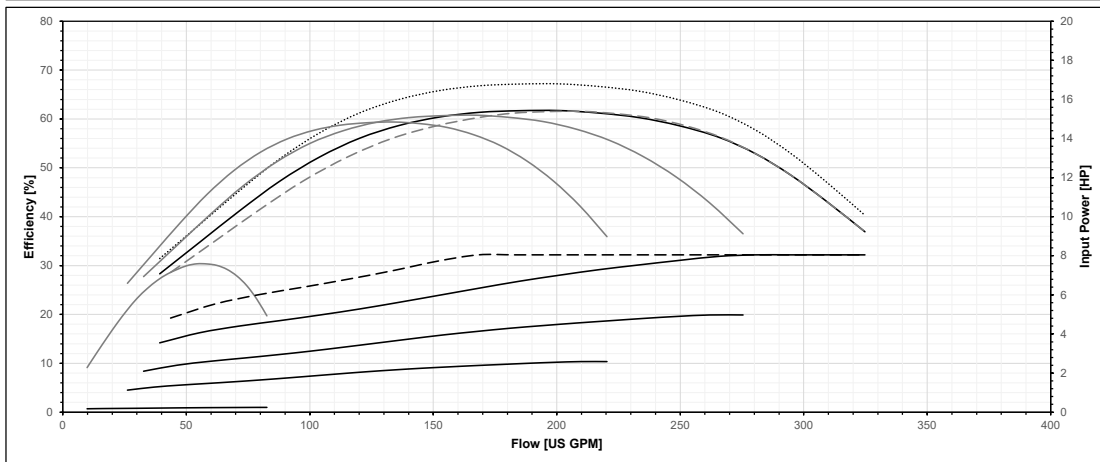
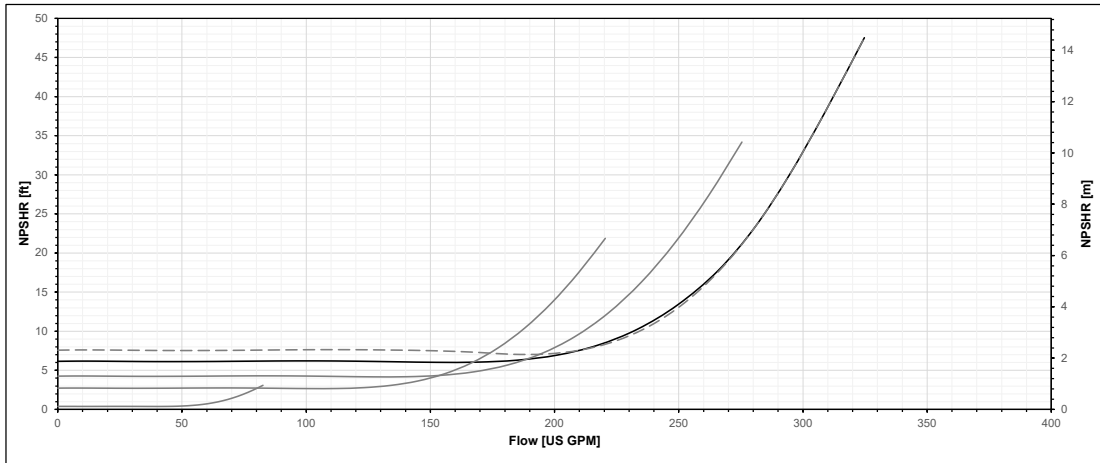
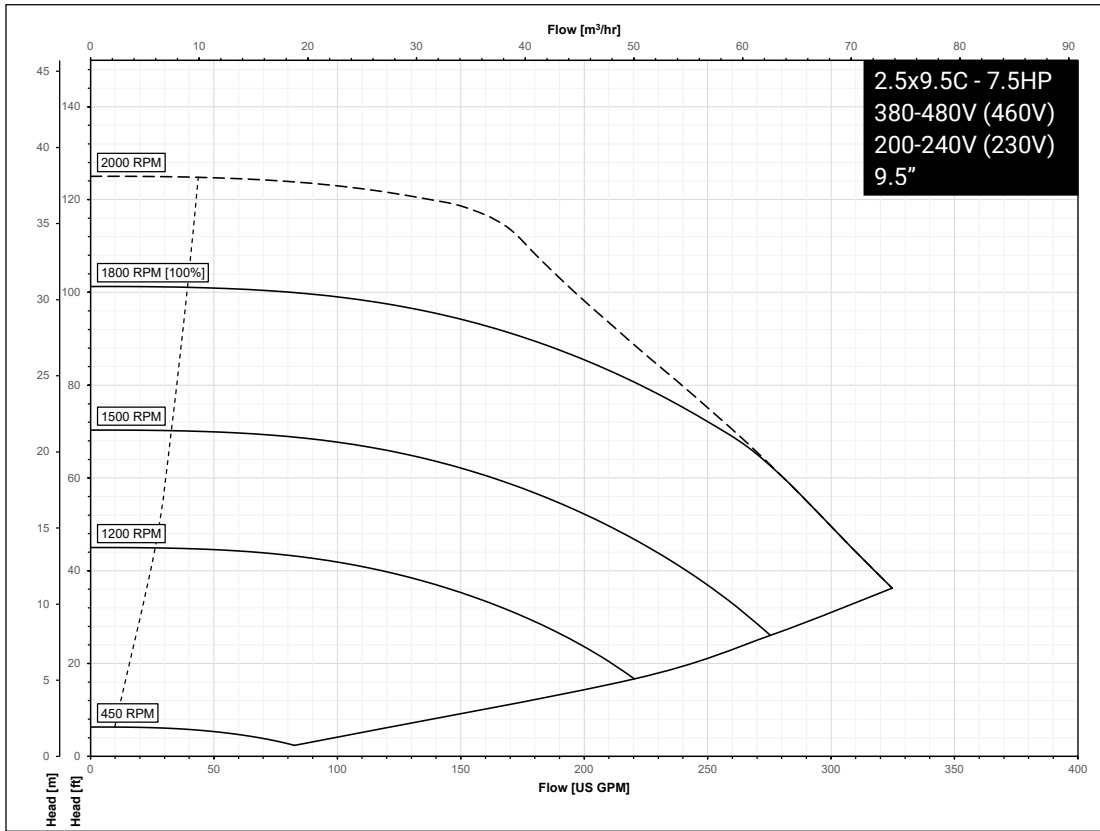

# SERIES e-80X Performance Curves for Low Speed Models

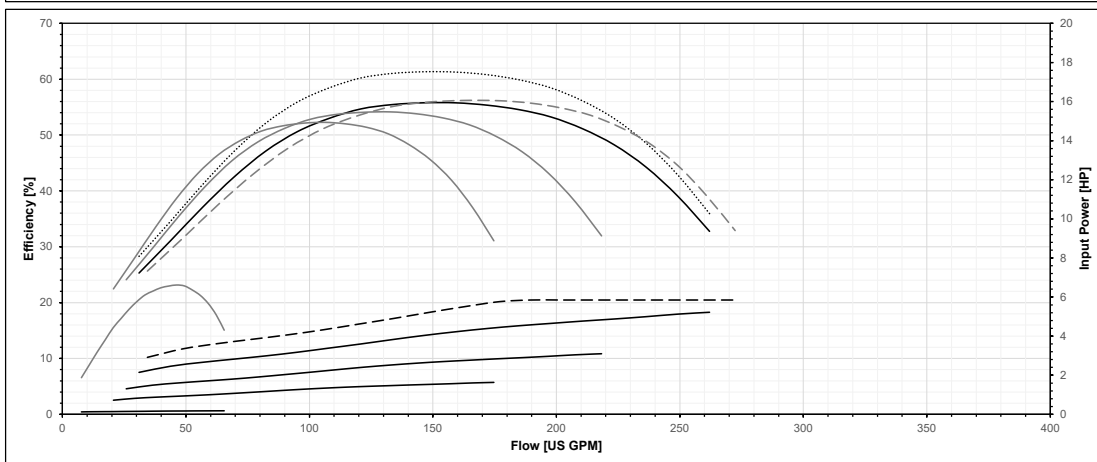
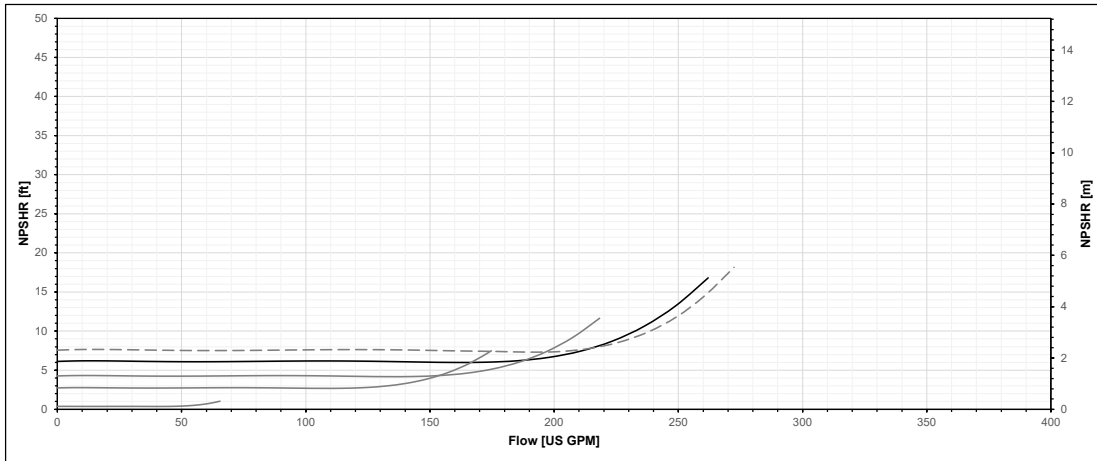
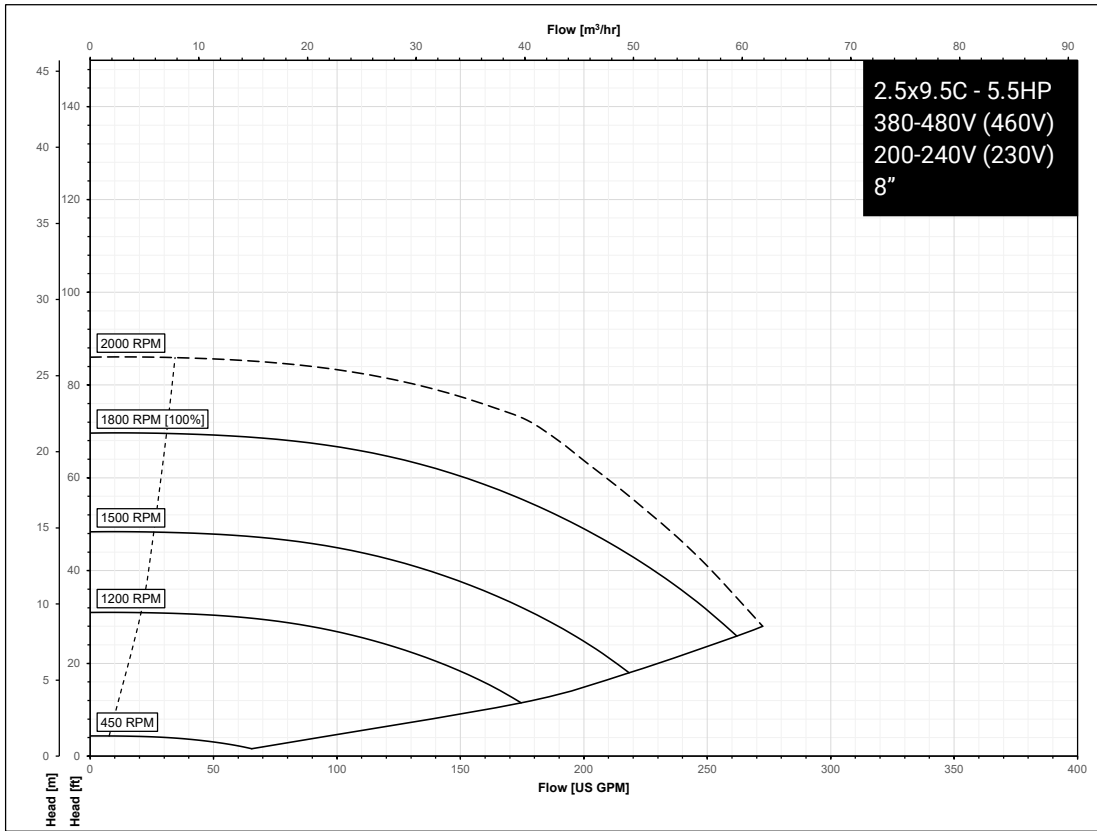

# SERIES e-80X Performance Curves for Low Speed Models

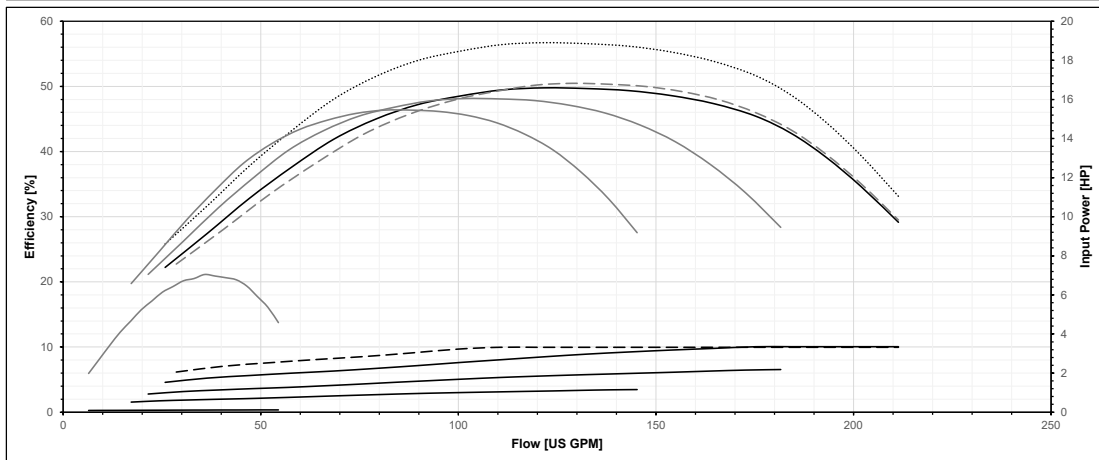
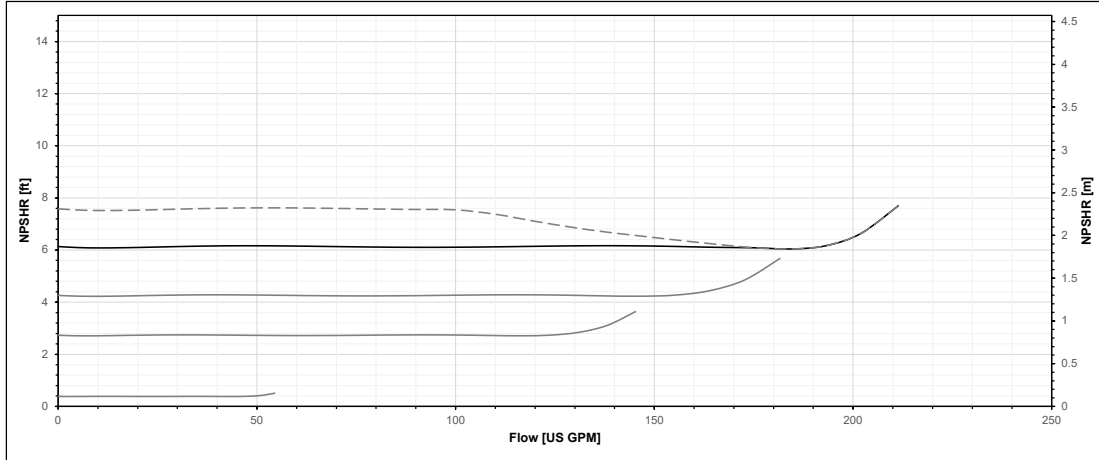
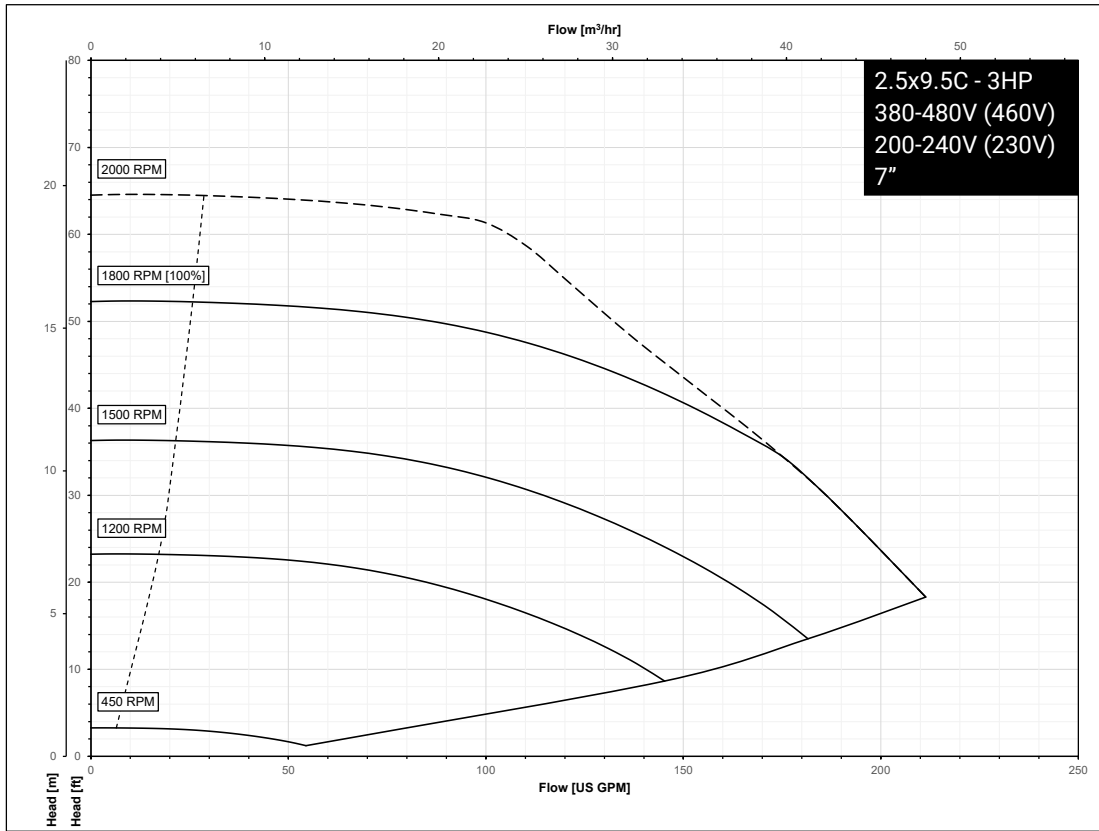

# SERIES e-80X Performance Curves for Low Speed Models

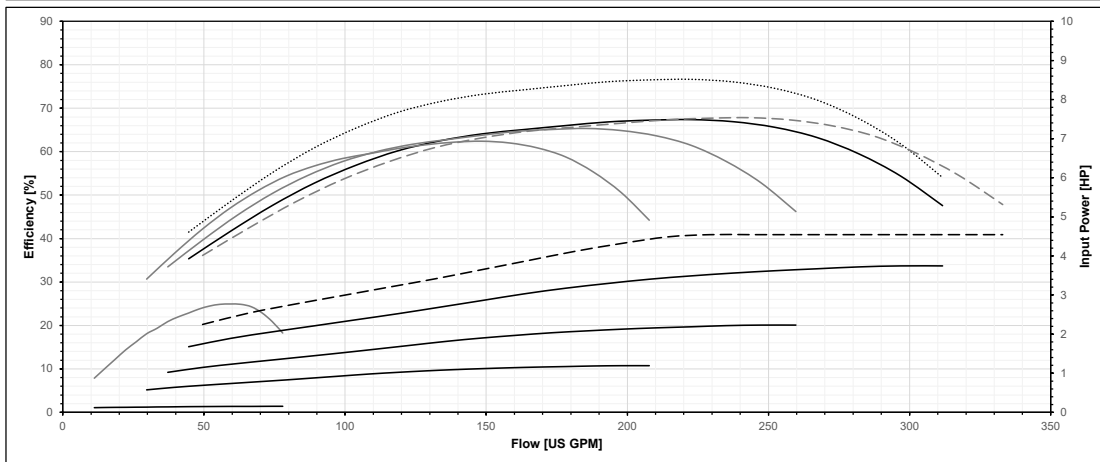
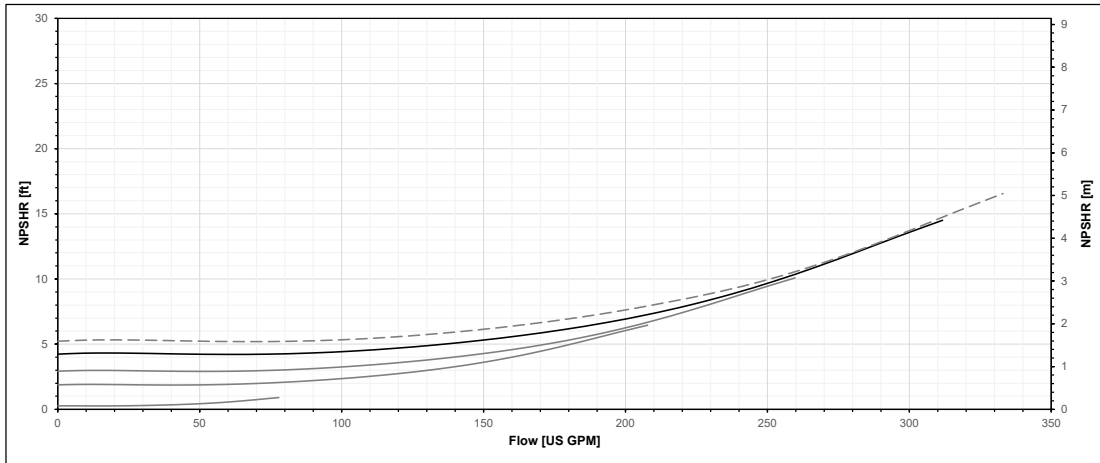
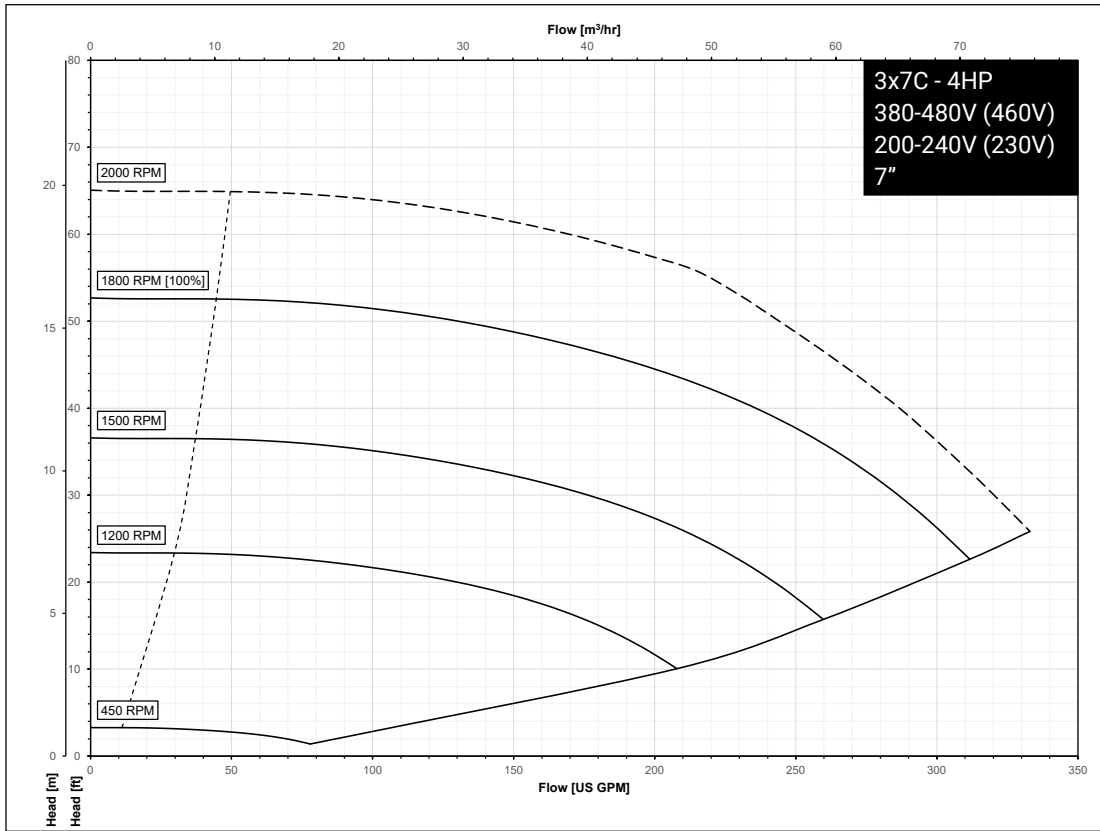

# SERIES e-80X Performance Curves for Low Speed Models

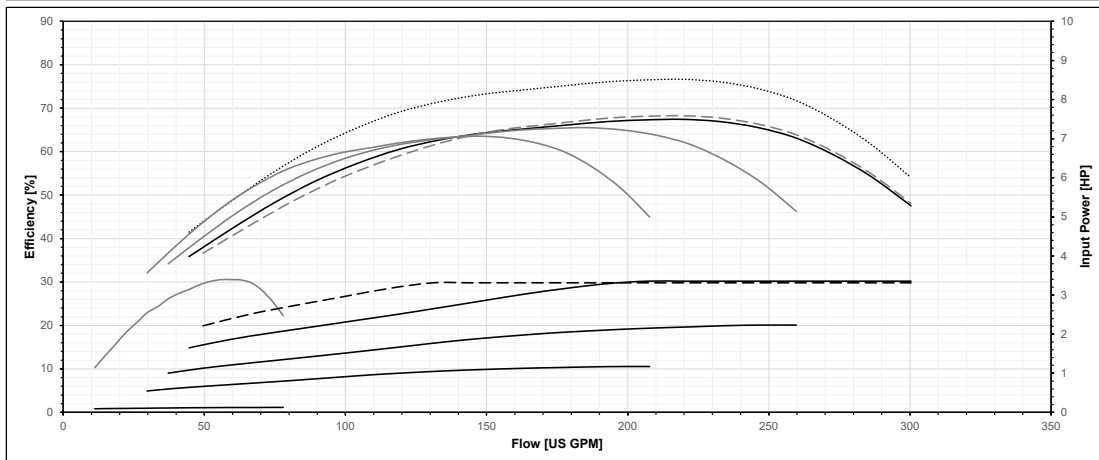
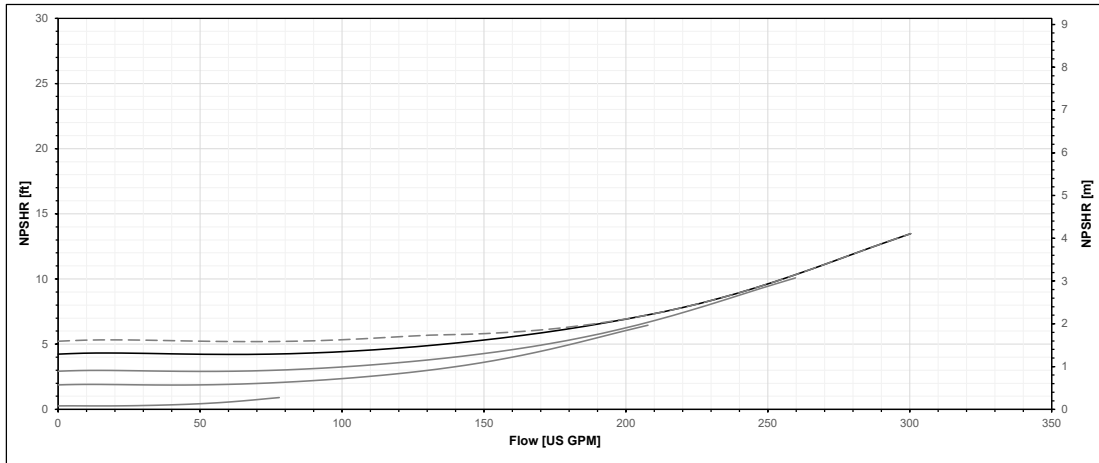
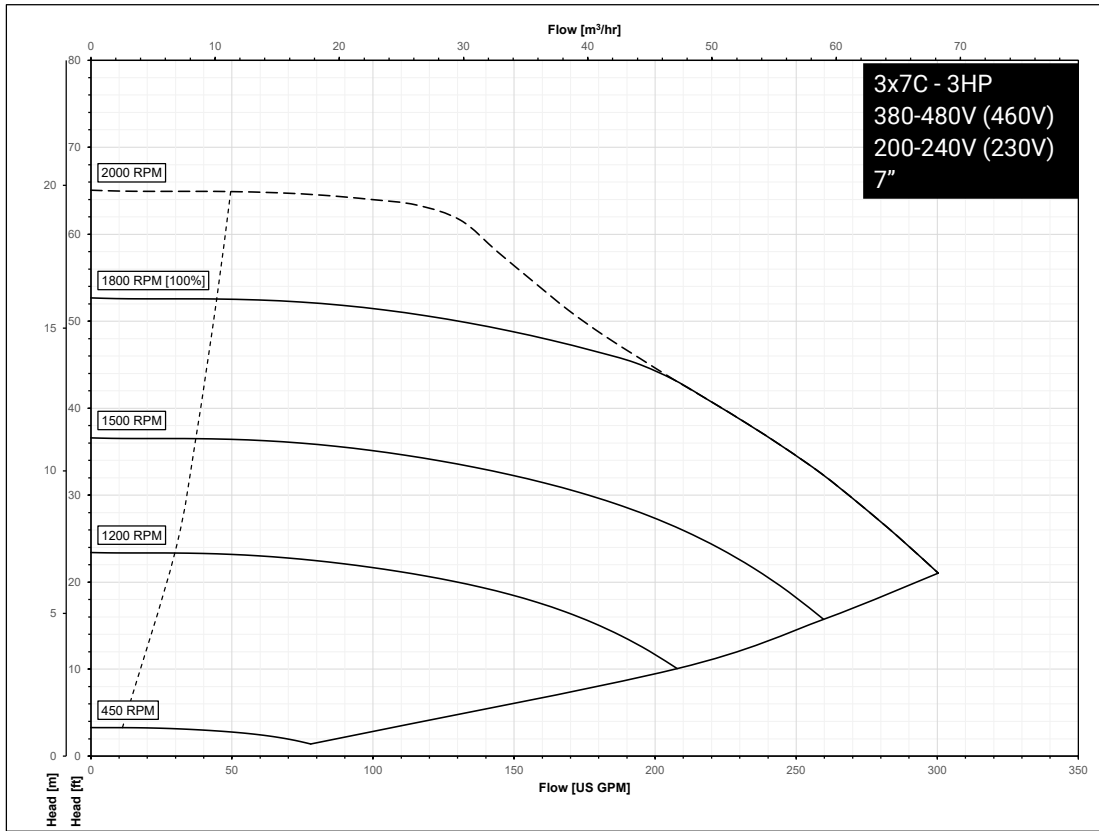

# SERIES e-80X Performance Curves for Low Speed Models

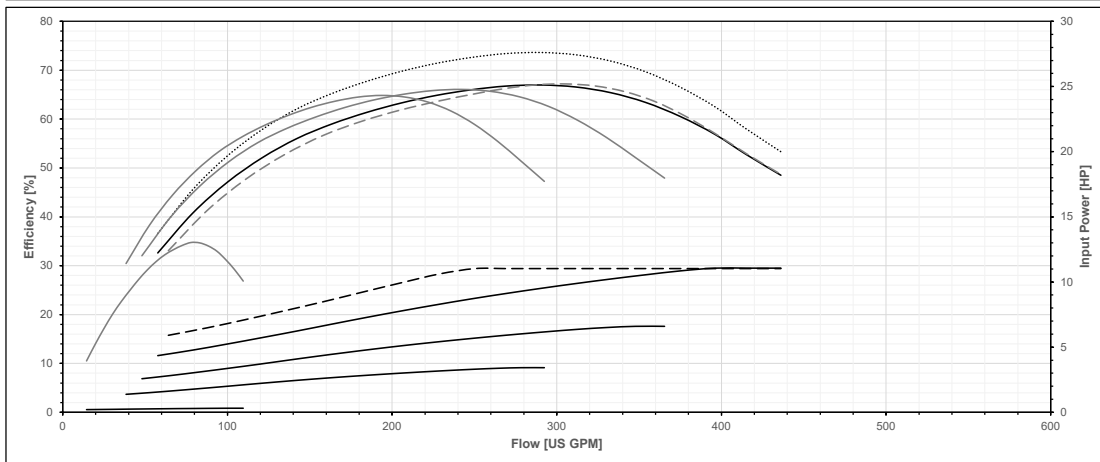
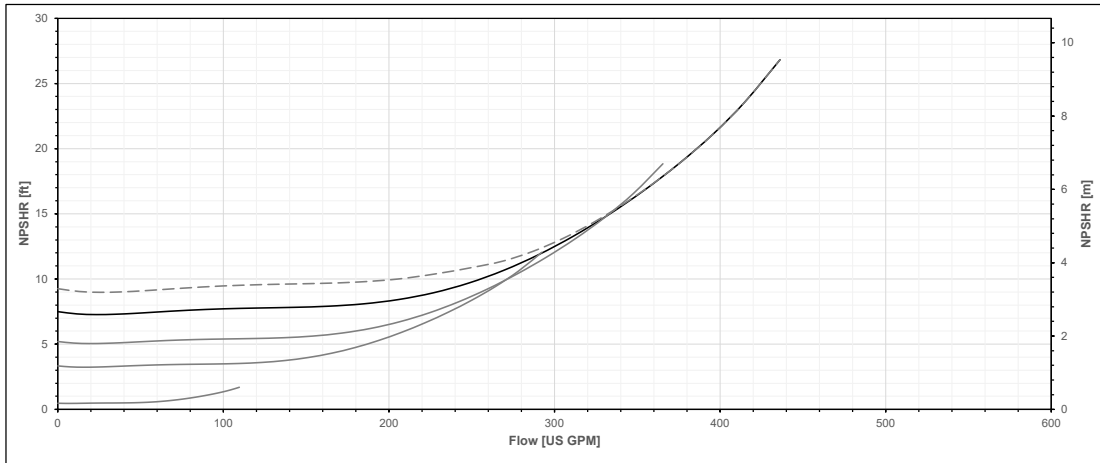
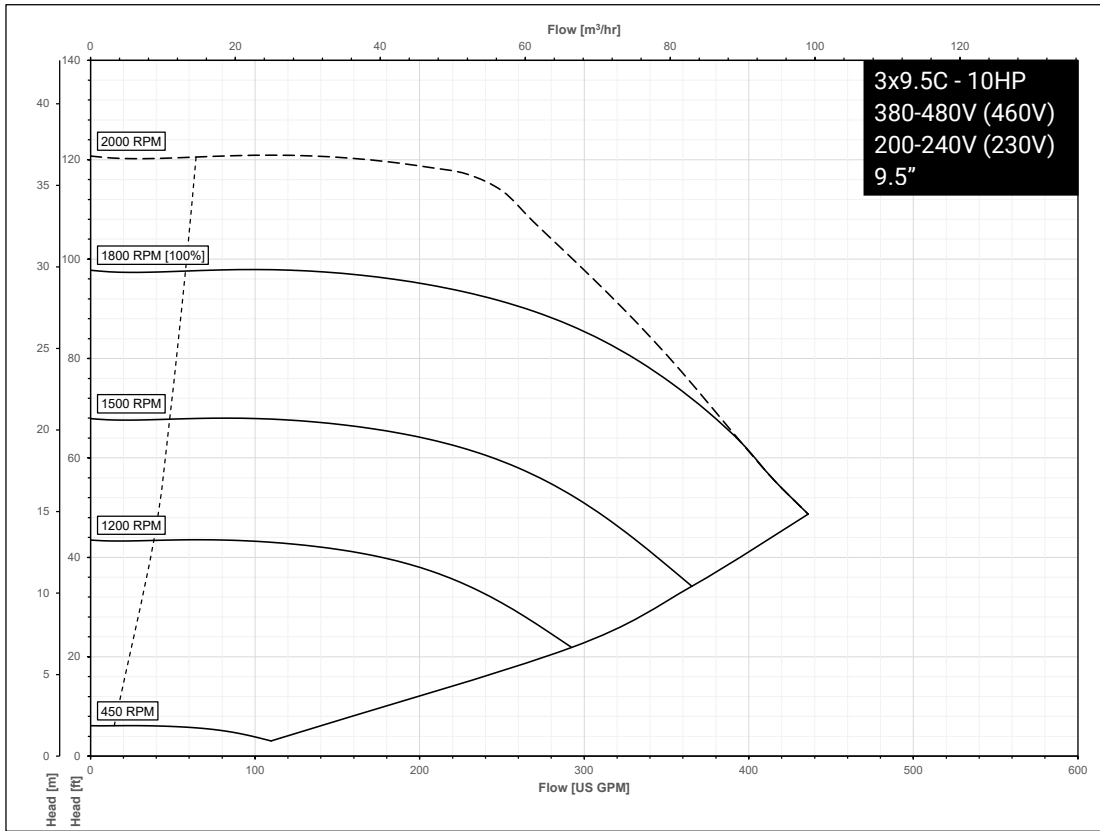

# SERIES e-80X Performance Curves for Low Speed Models

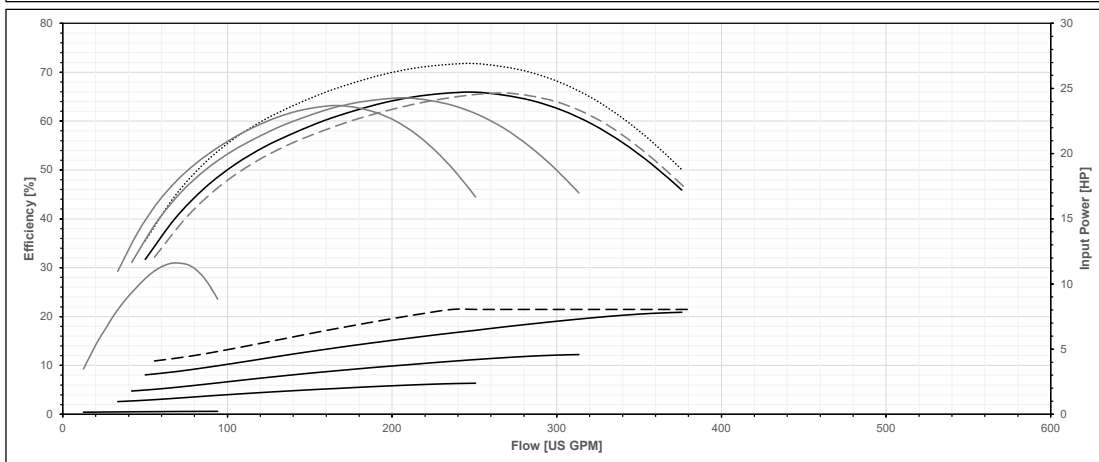
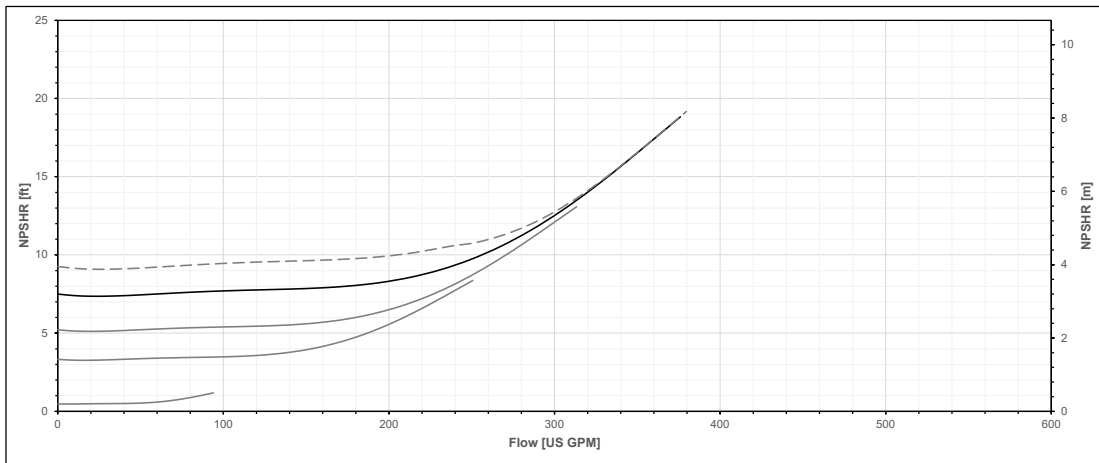
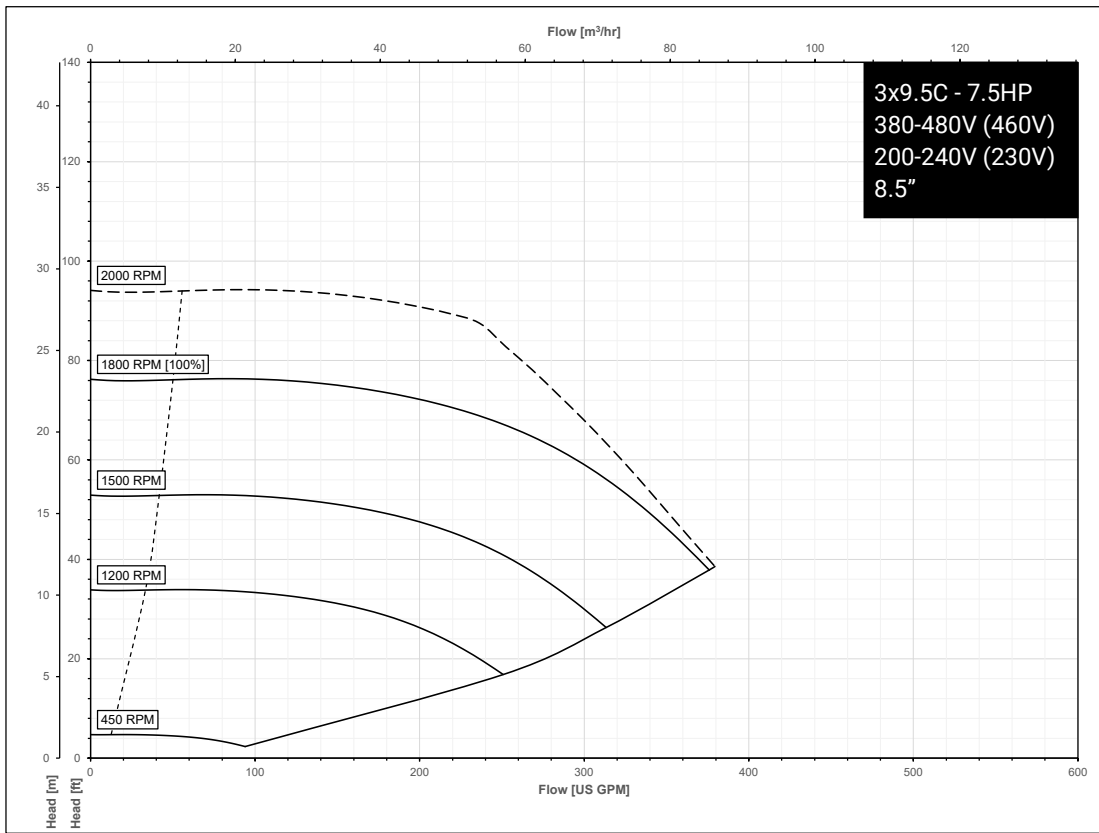

# SERIES e-80X Performance Curves for Low Speed Models

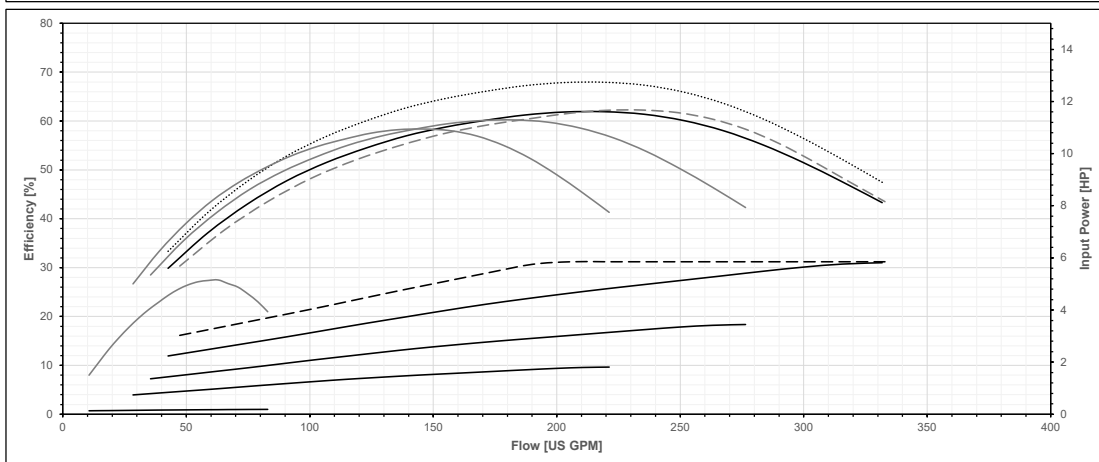
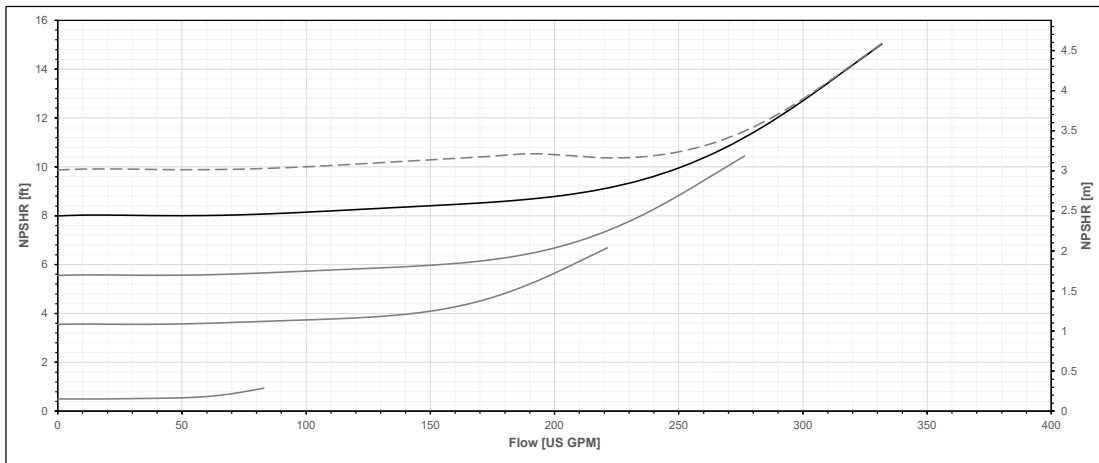
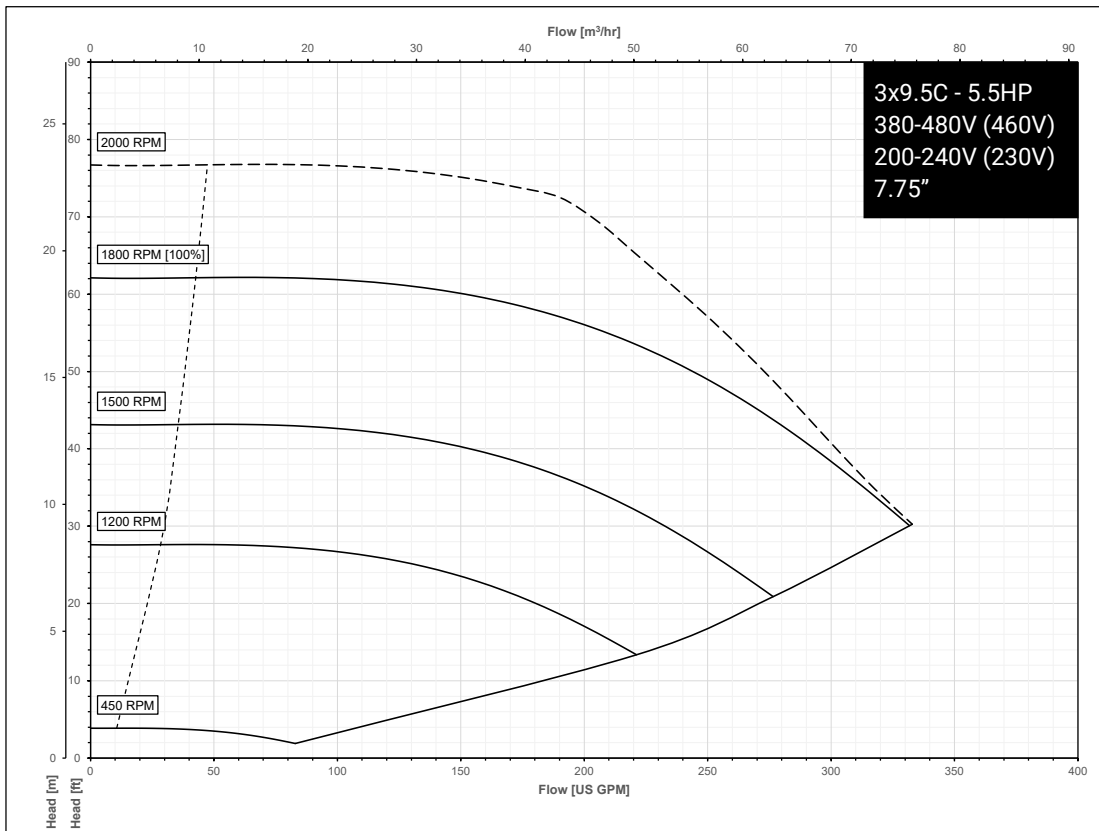

# SERIES e-80X Performance Curves for Low Speed Models

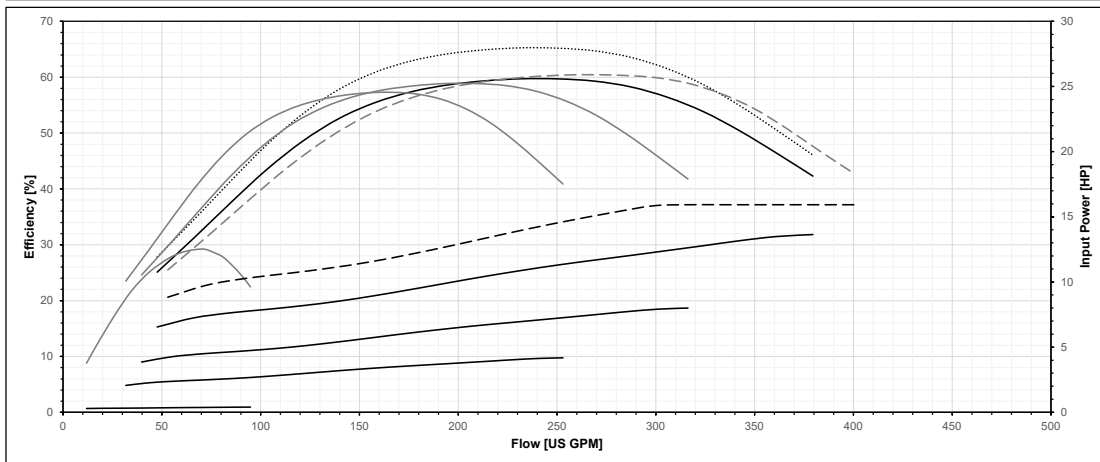
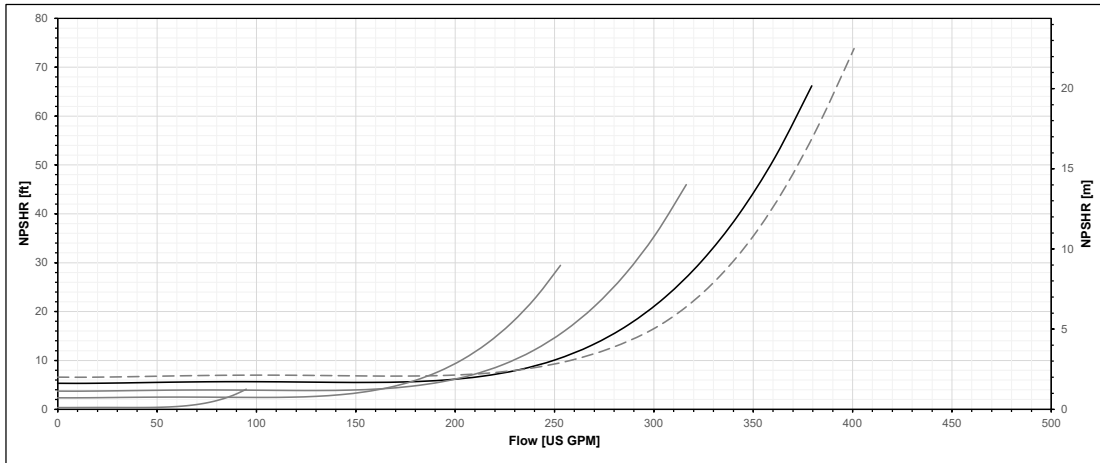
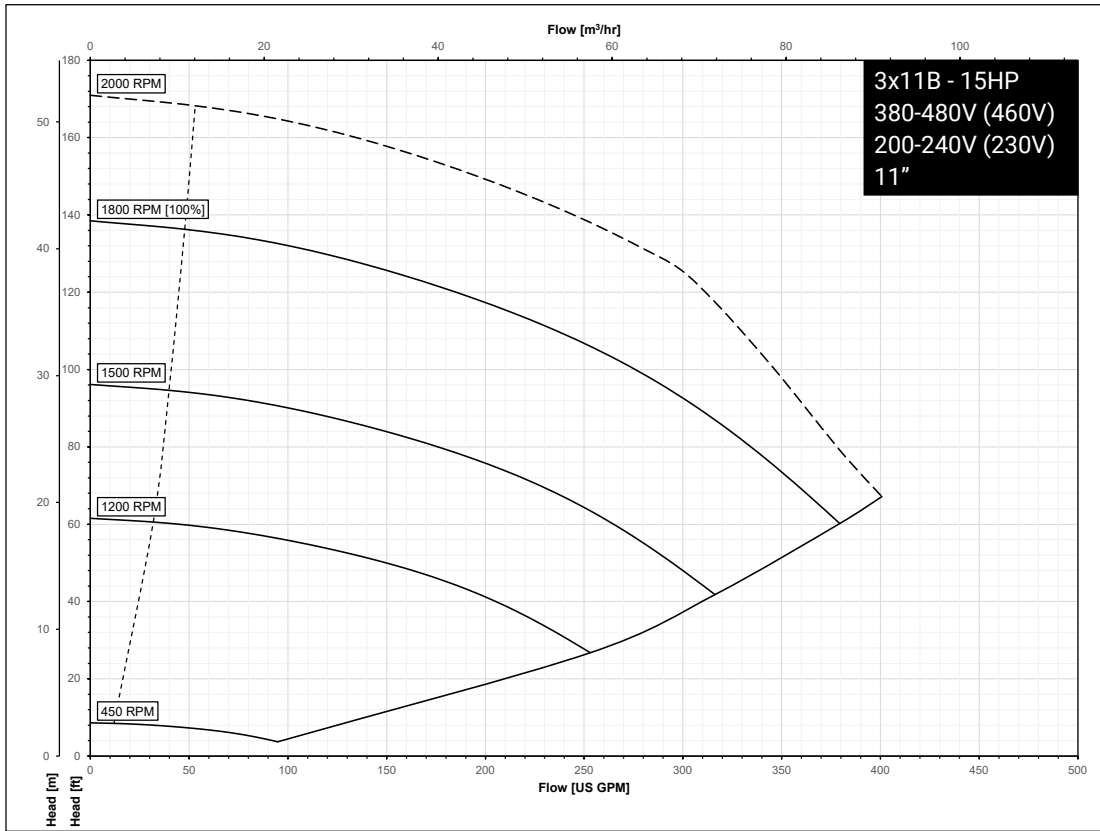

# SERIES e-80X Performance Curves for Low Speed Models

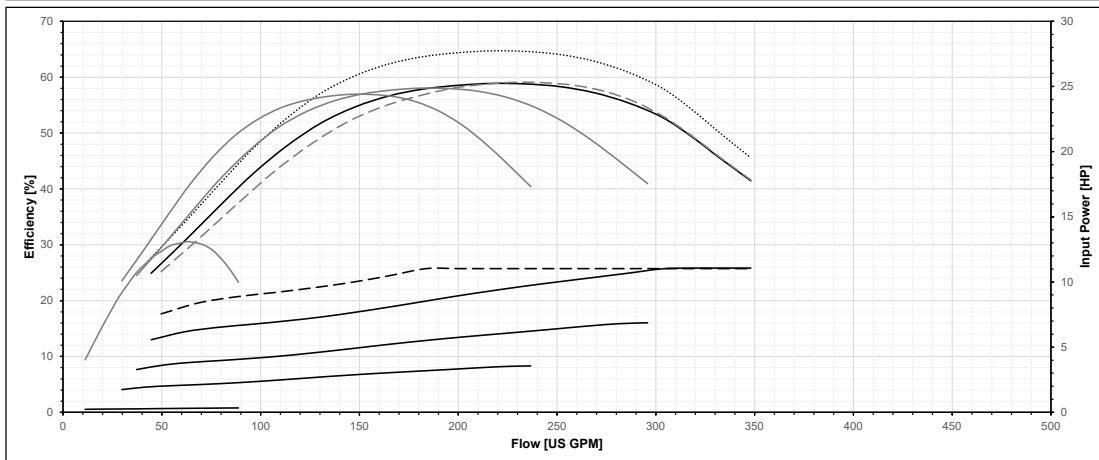
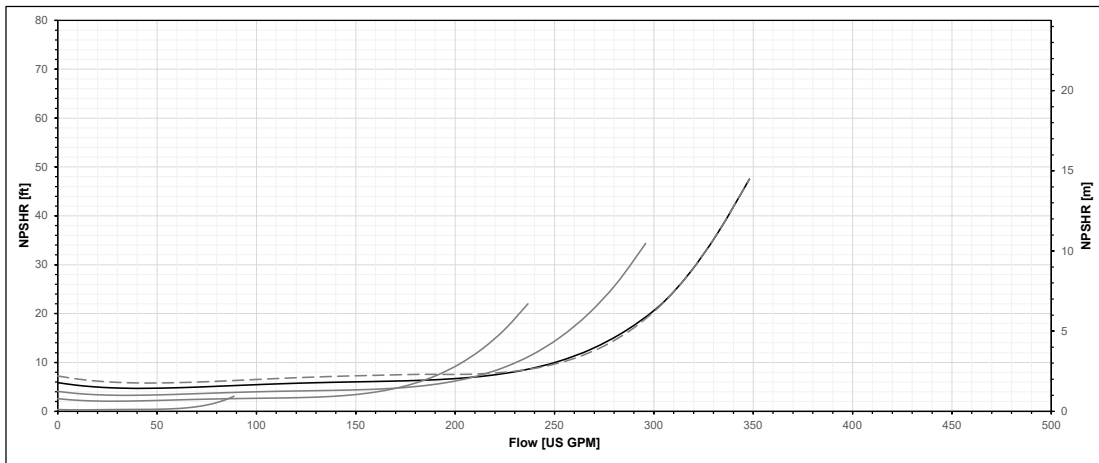
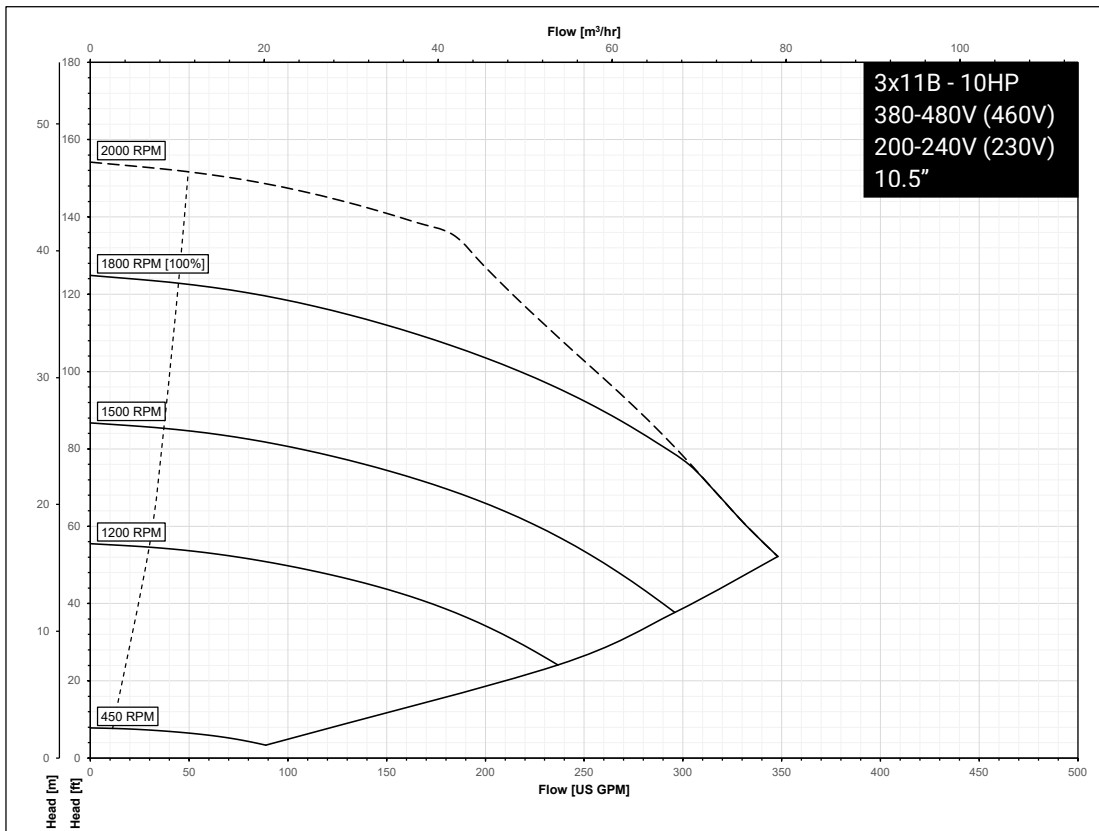

# SERIES e-80X Performance Curves for Low Speed Models

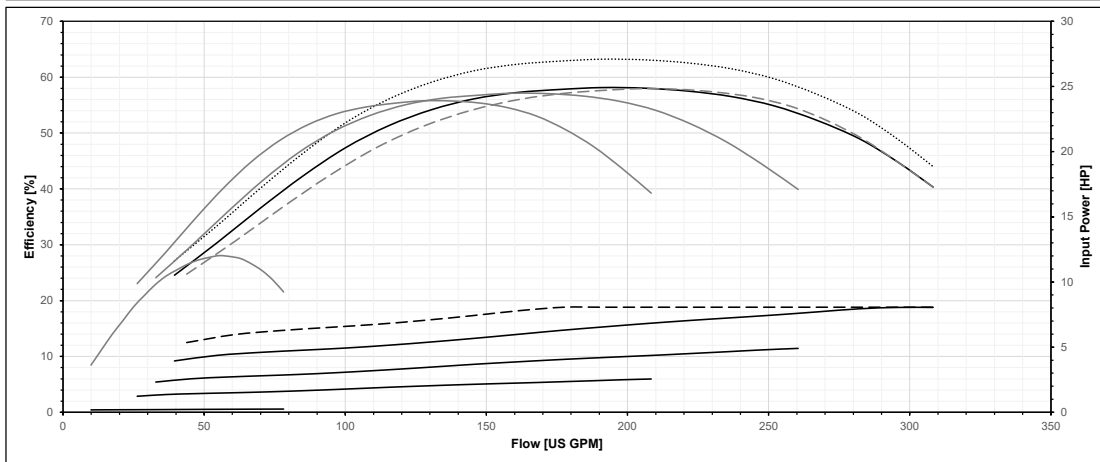
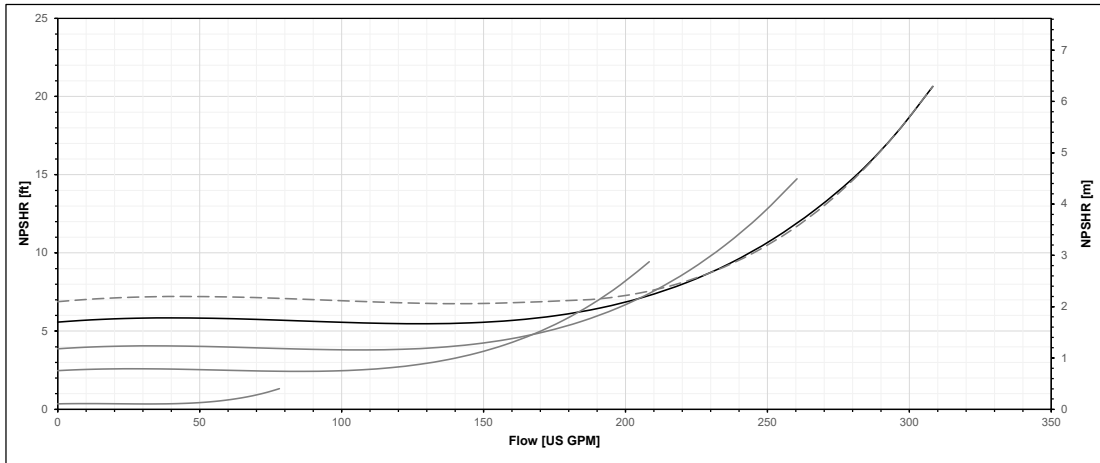
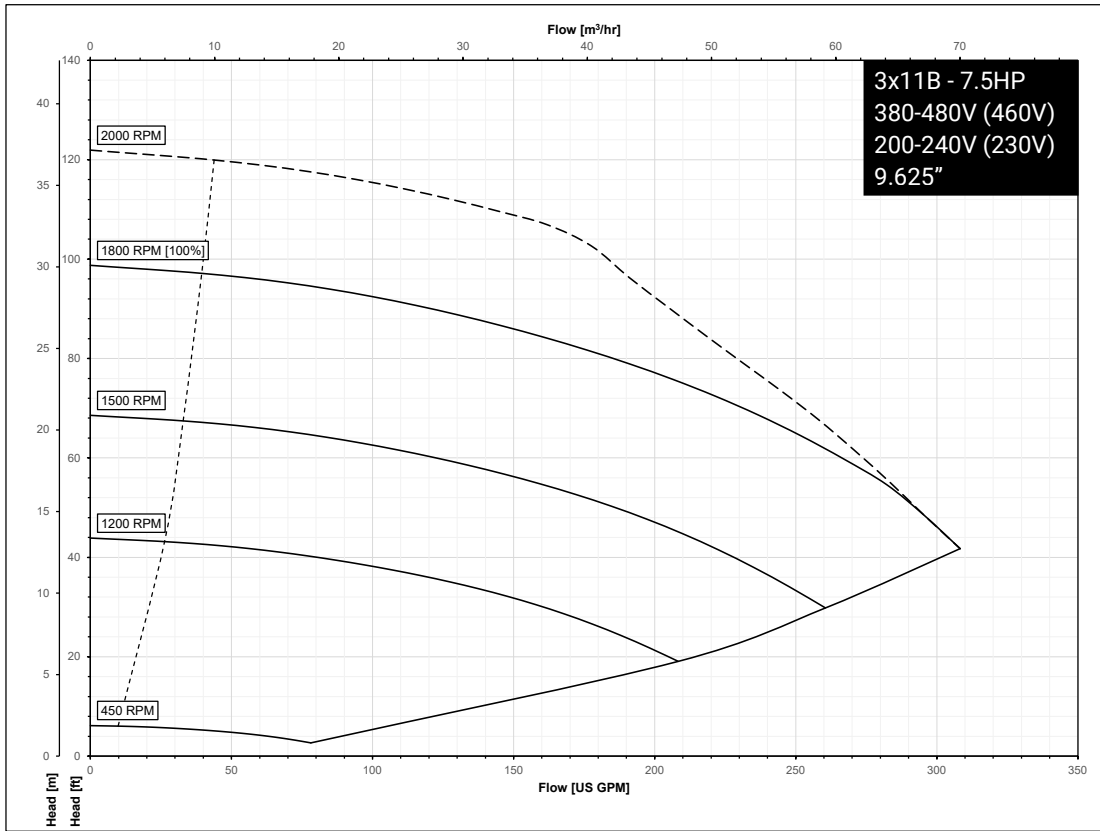

# SERIES e-80X Performance Curves for Low Speed Models

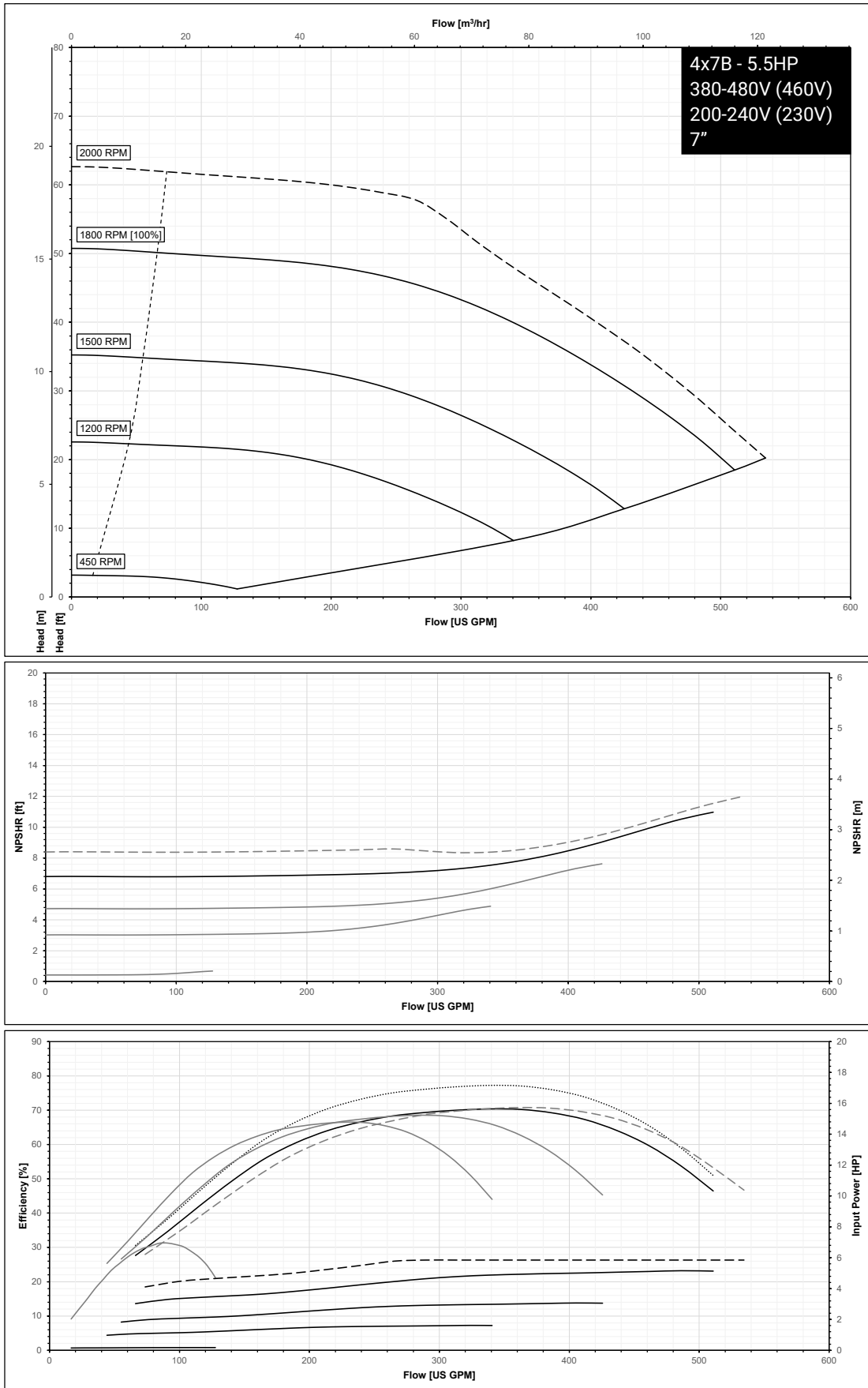

# SERIES e-80X Performance Curves for Low Speed Models

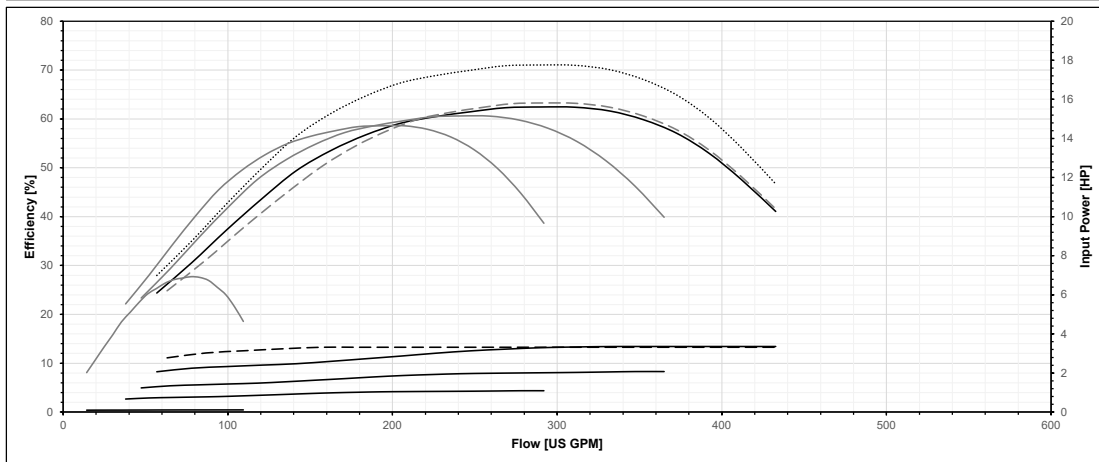
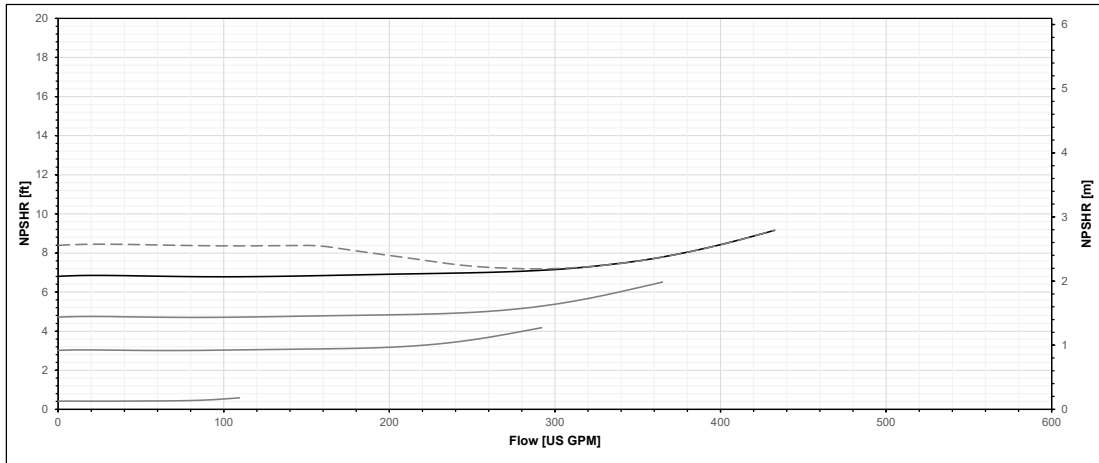
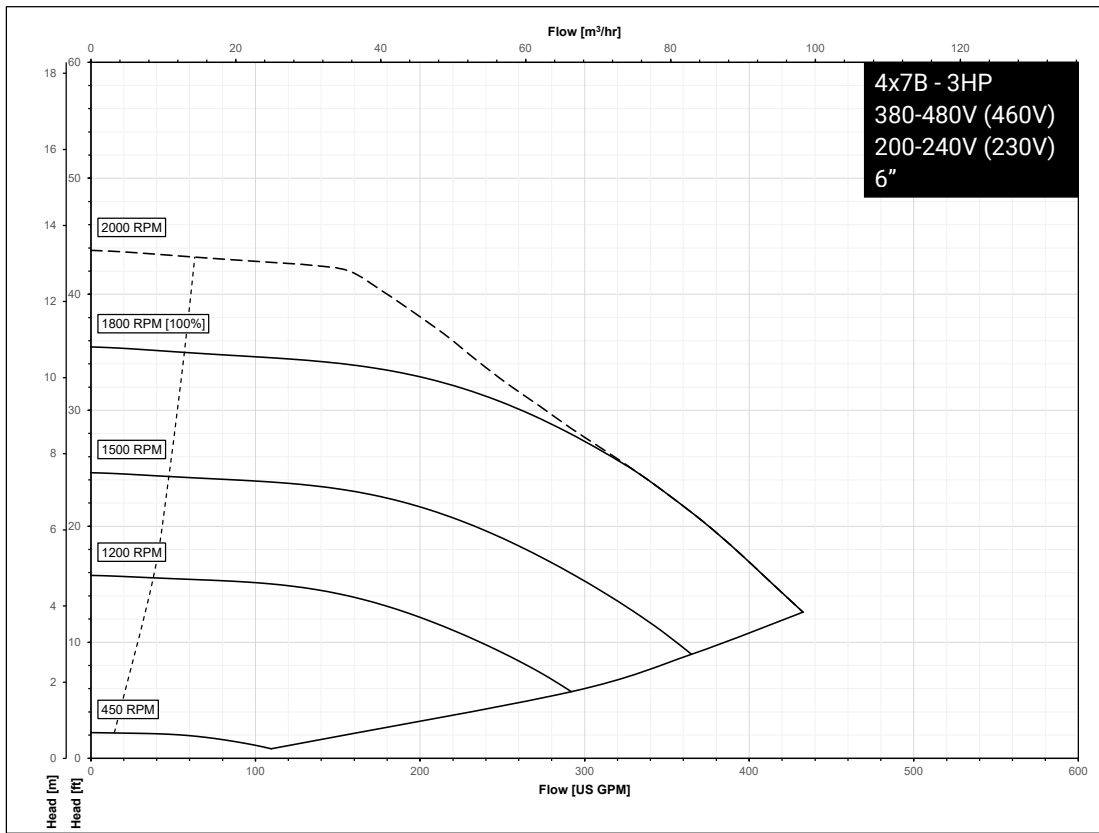

# SERIES e-80X Performance Curves for Low Speed Models

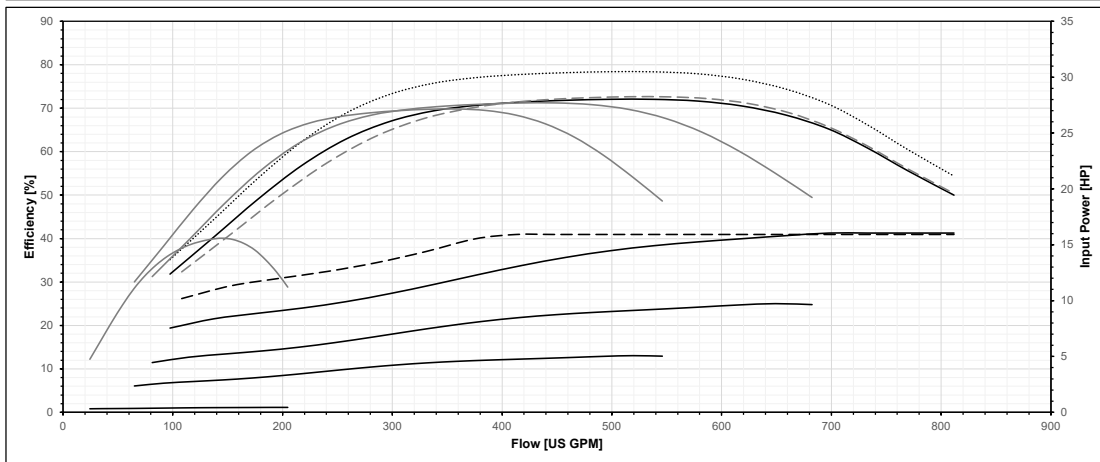
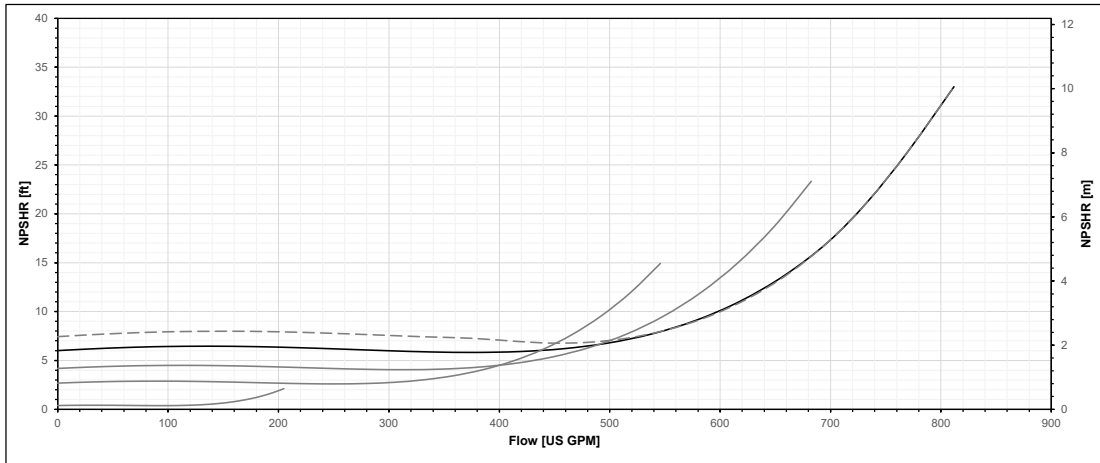
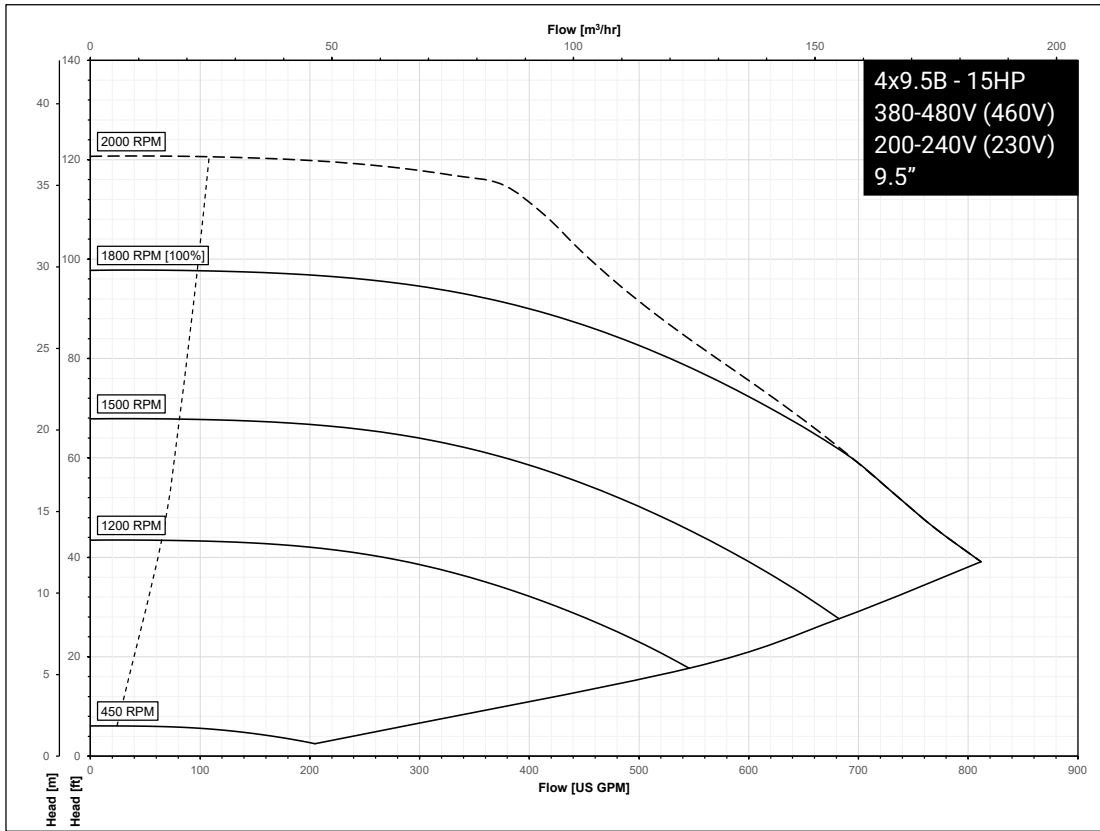

# SERIES e-80X Performance Curves for Low Speed Models

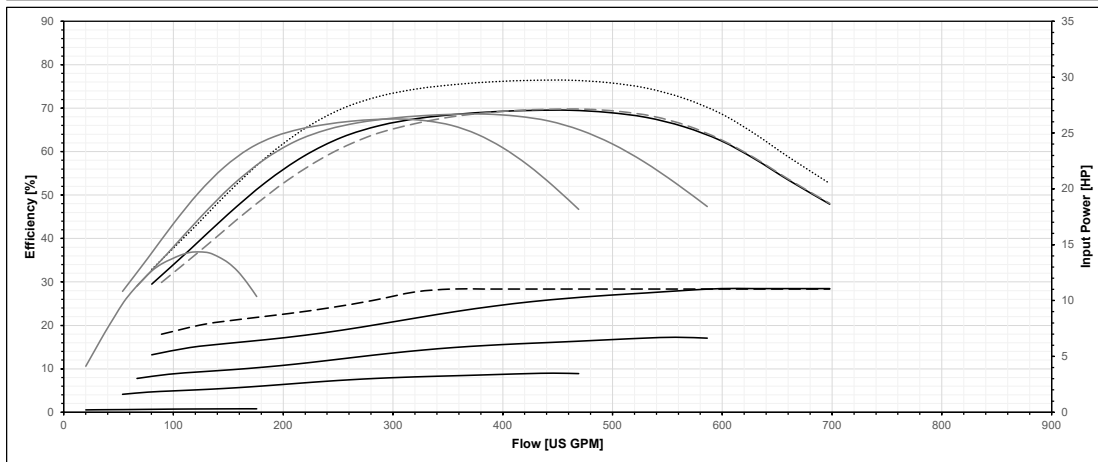
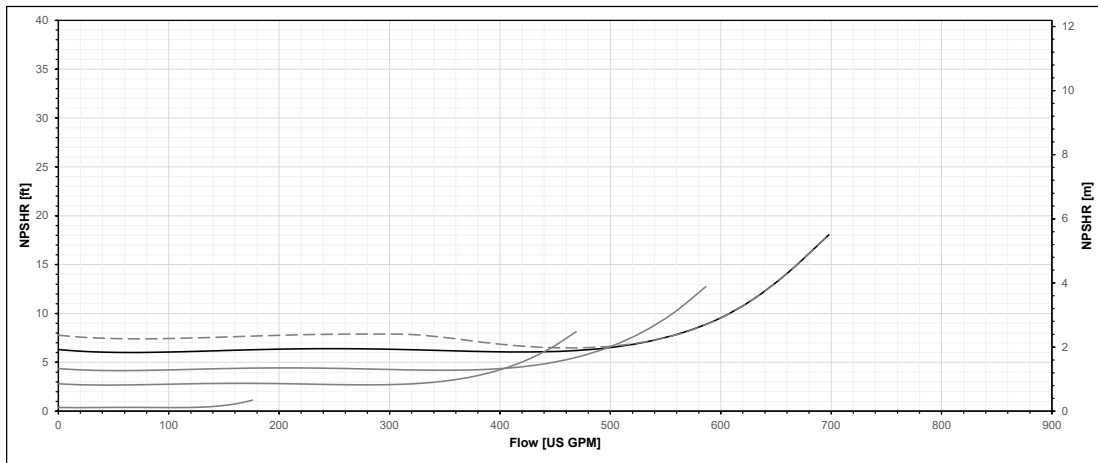
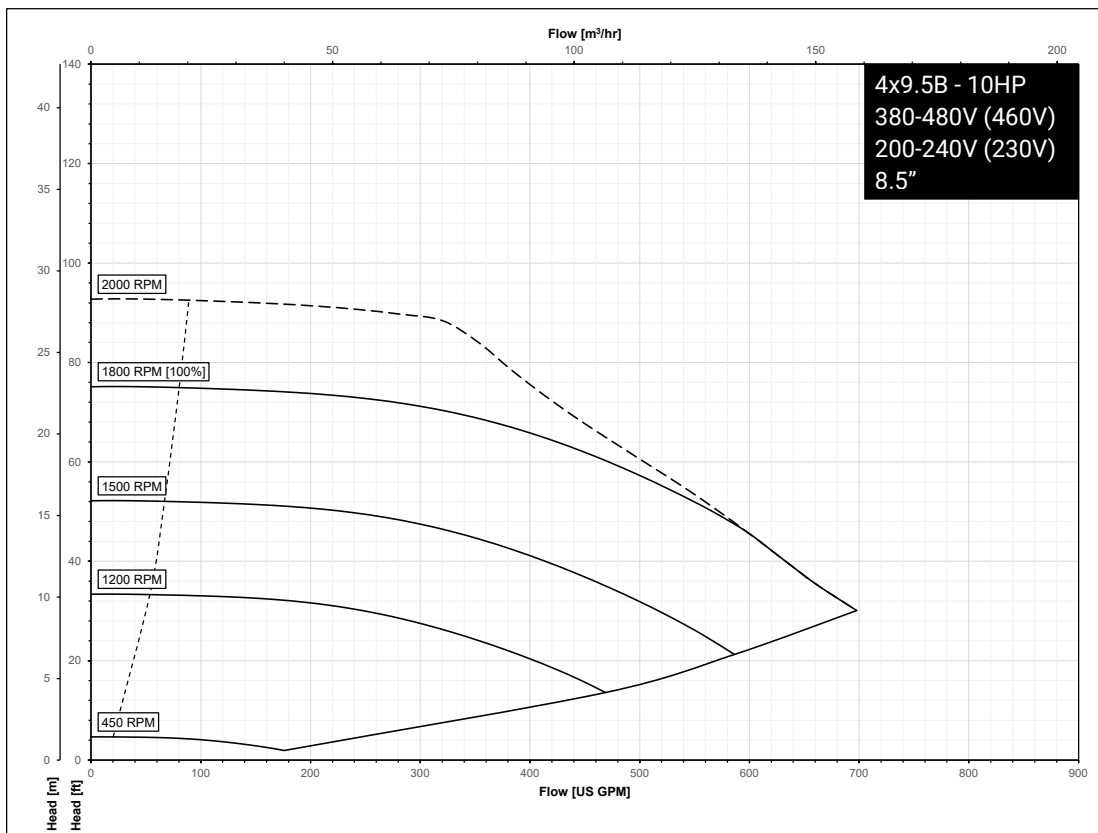

# SERIES e-80X Performance Curves for Low Speed Models

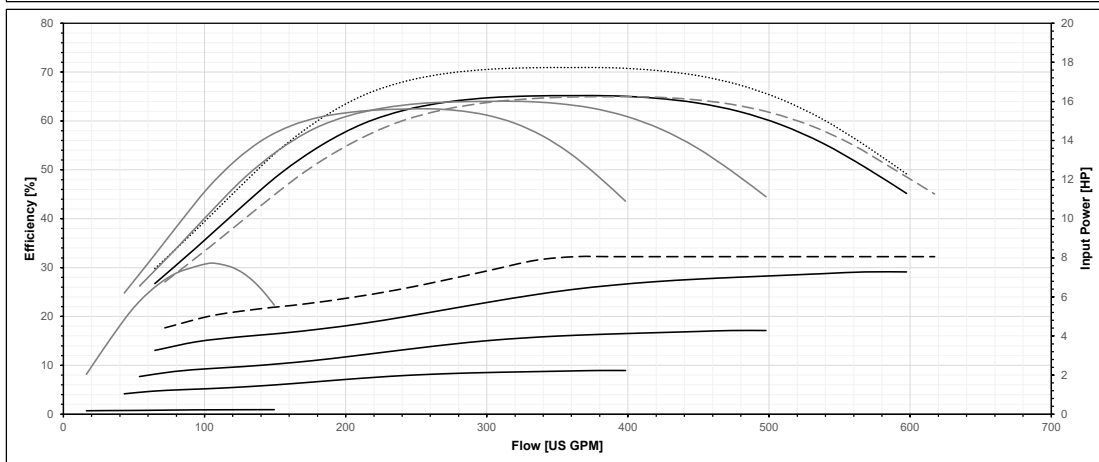
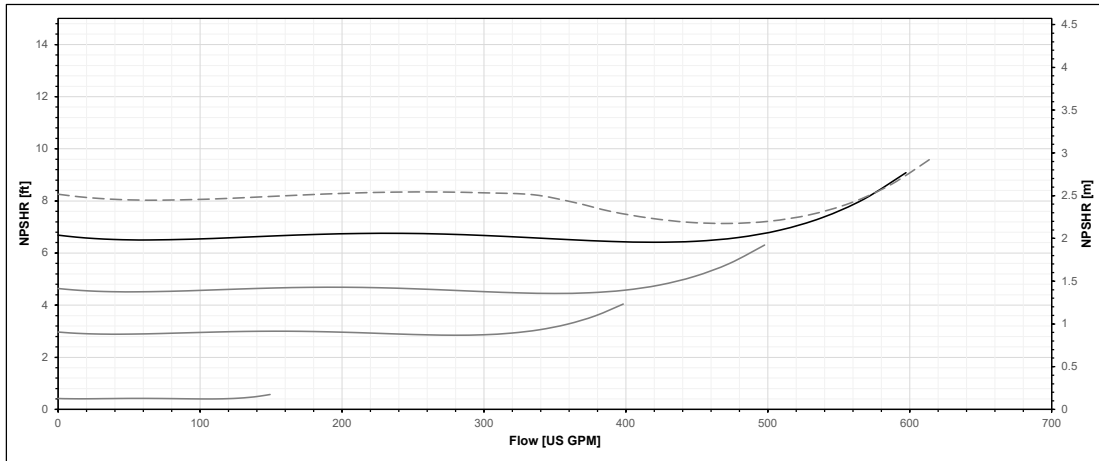
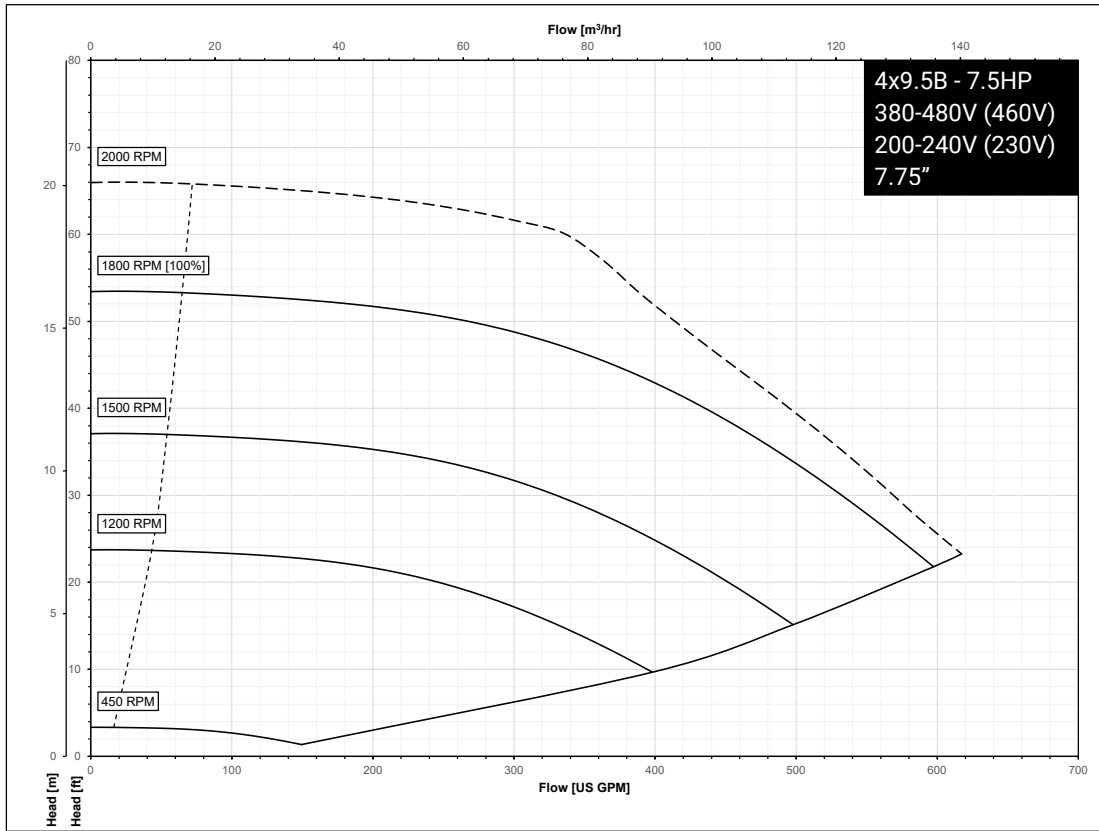

# SERIES e-80X Performance Curves for Low Speed Models

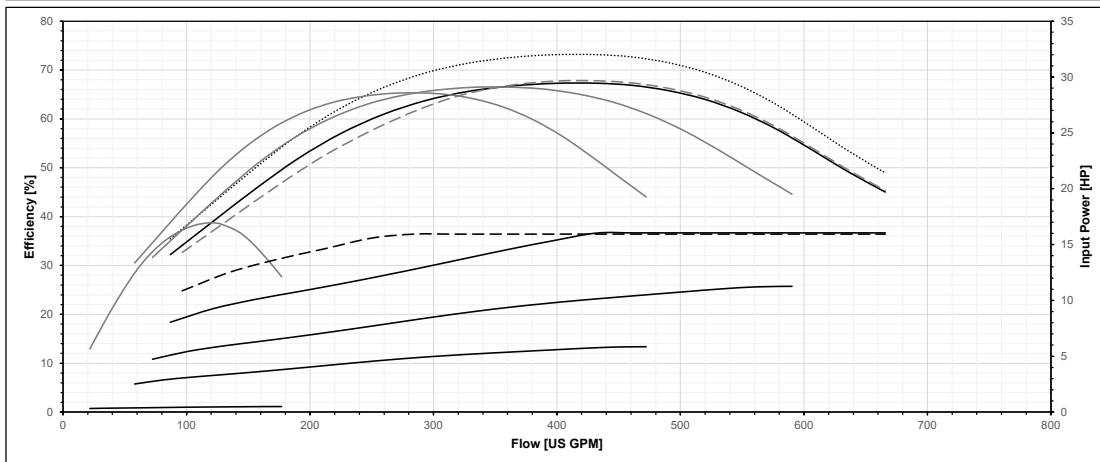
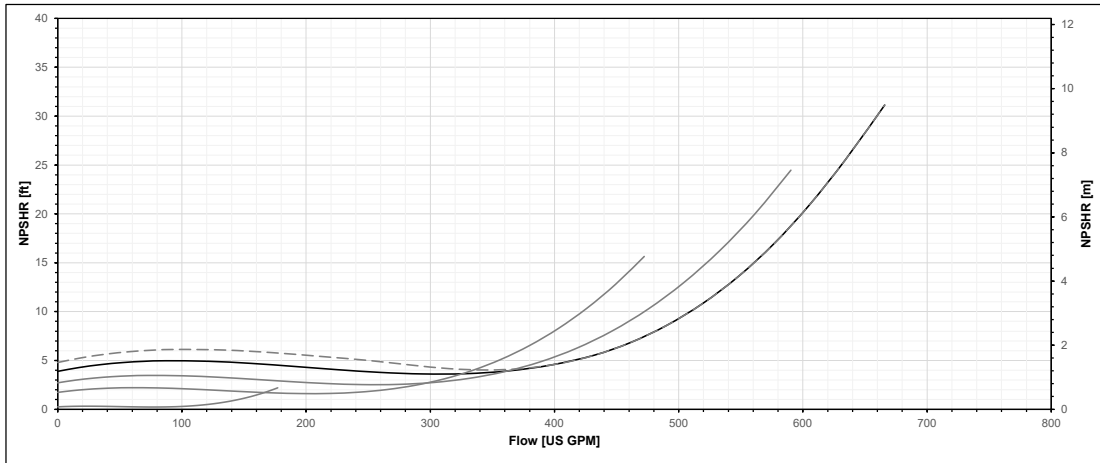
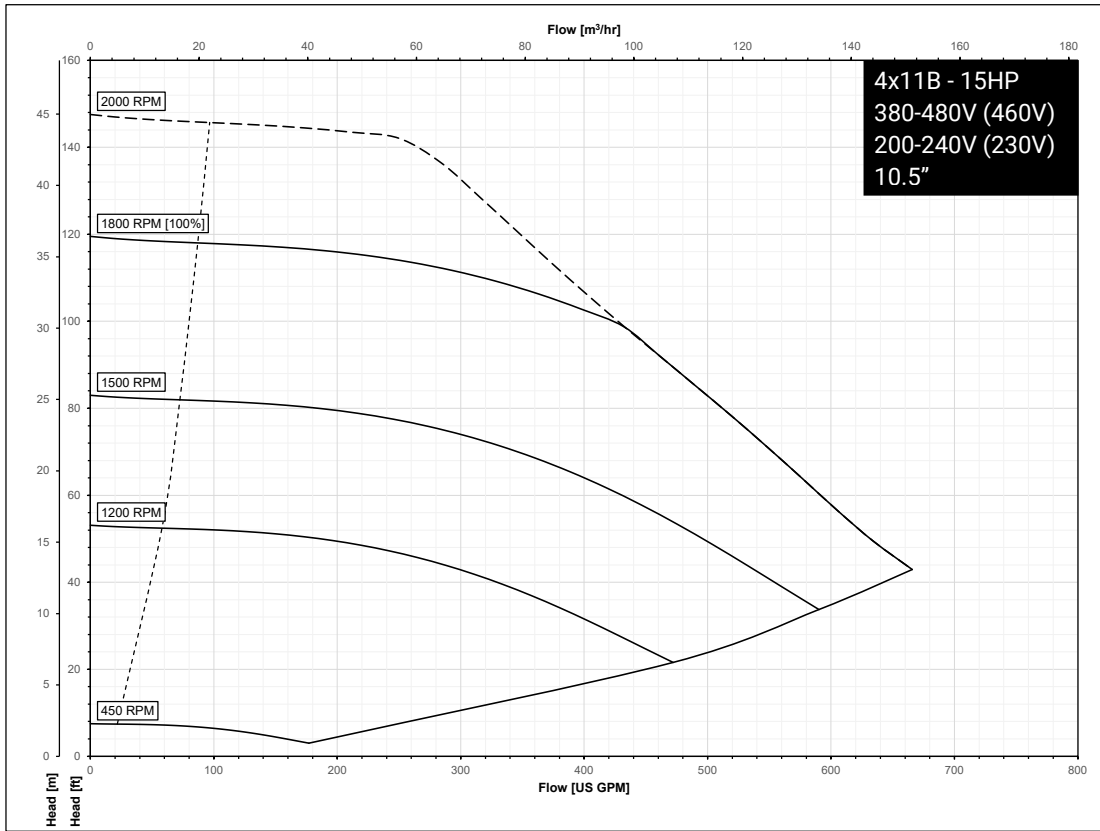

# SERIES e-80X Performance Curves for Low Speed Models

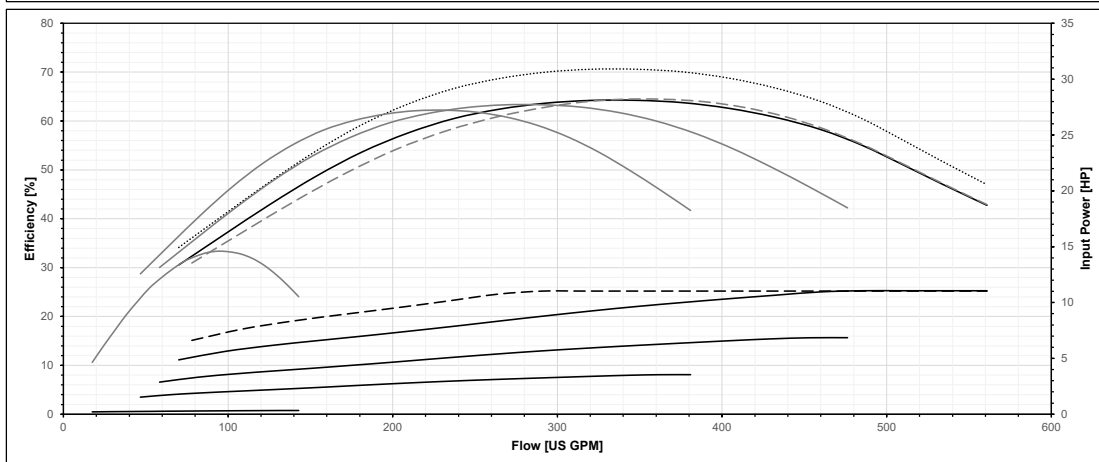
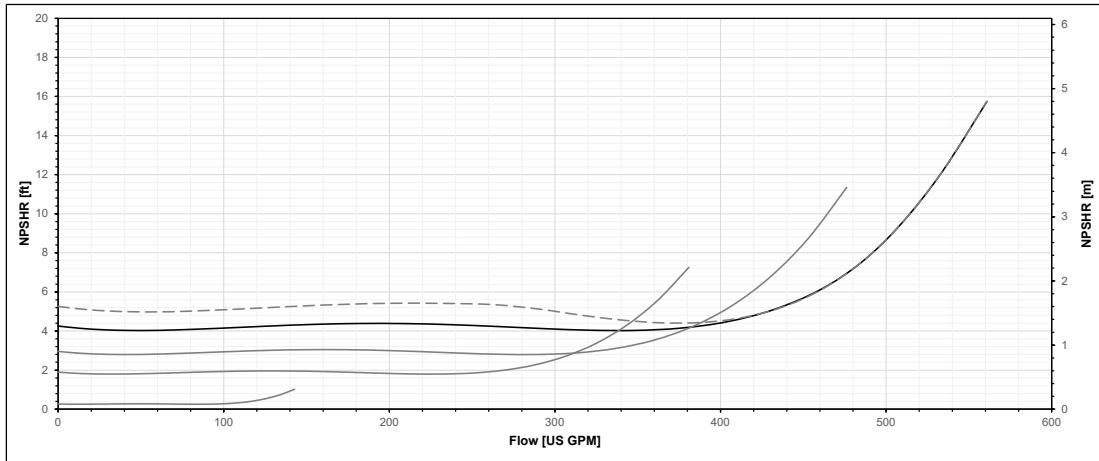
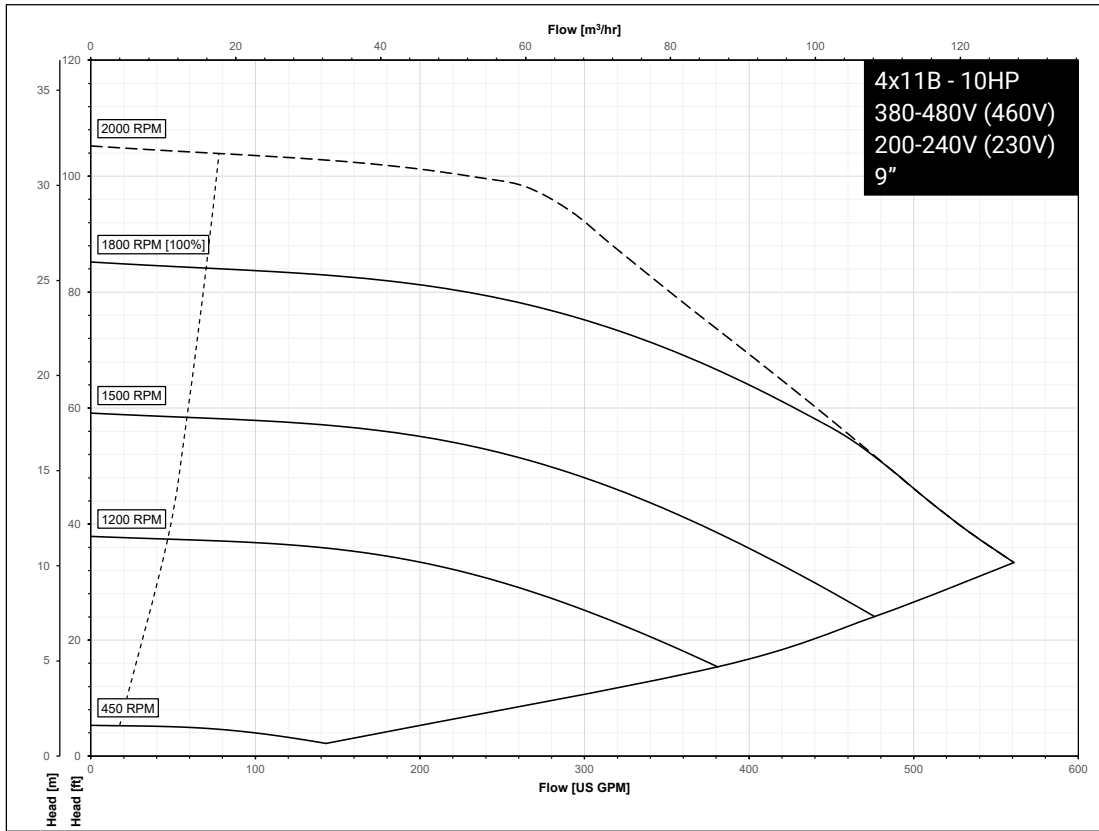

# SERIES e-80X Performance Curves for Low Speed Models

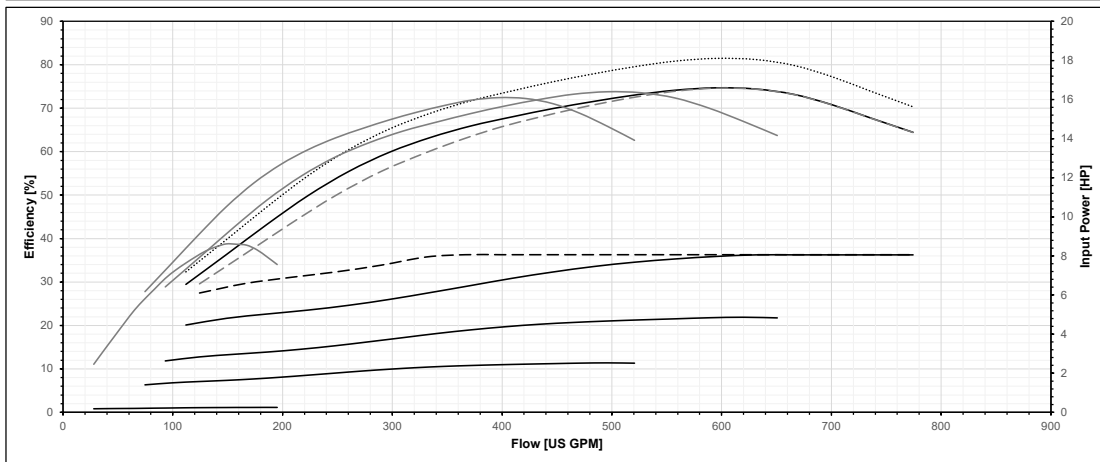
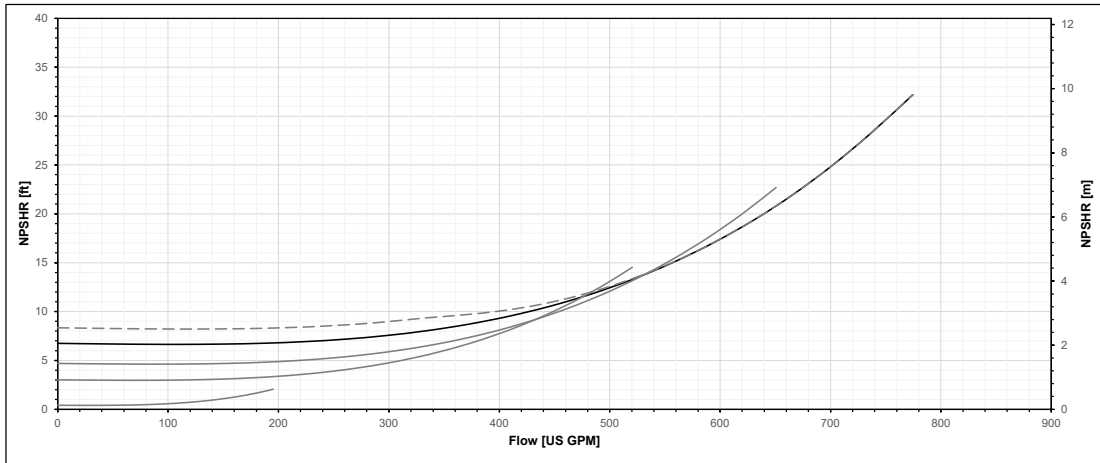
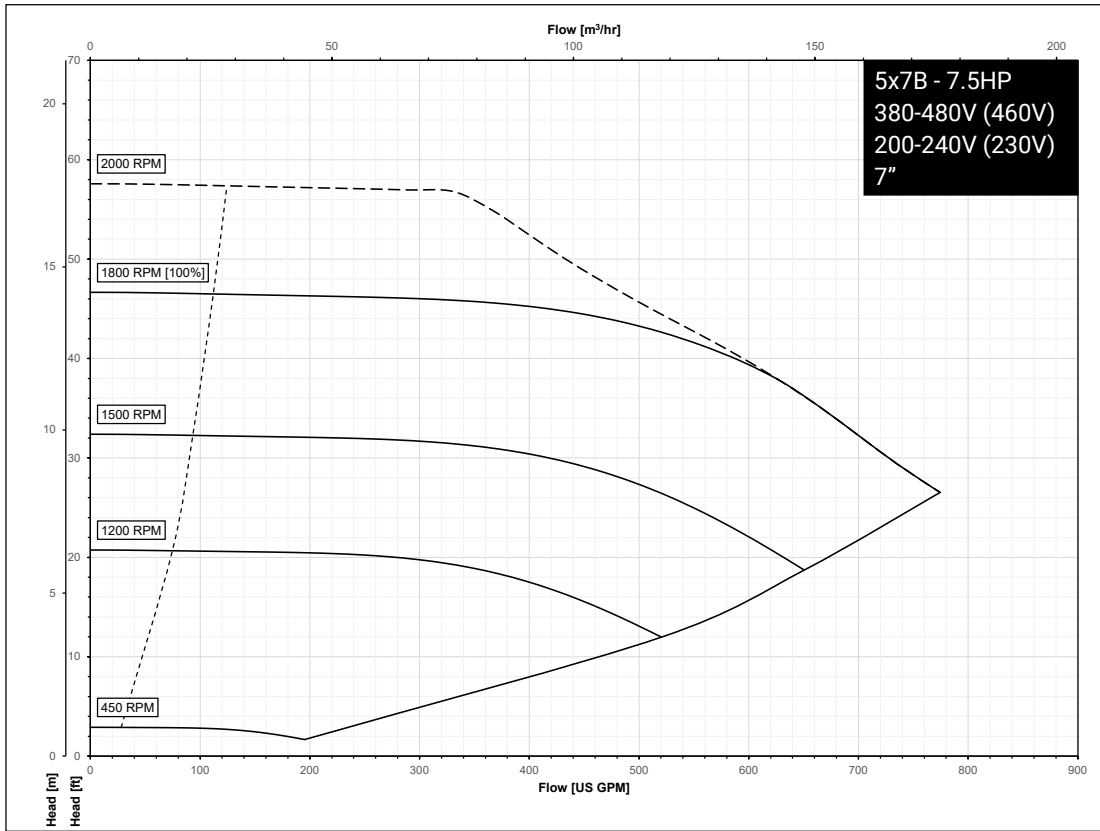

# SERIES e-80X Performance Curves for Low Speed Models

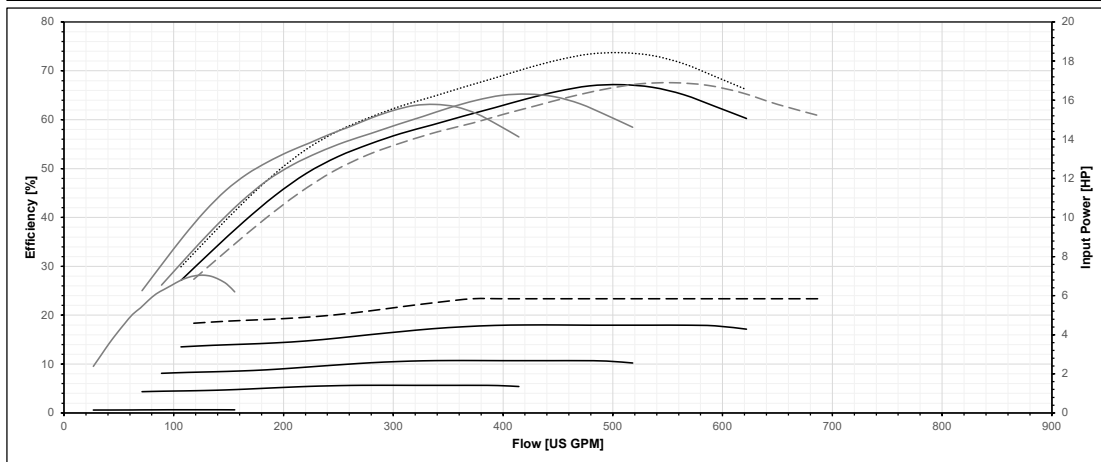
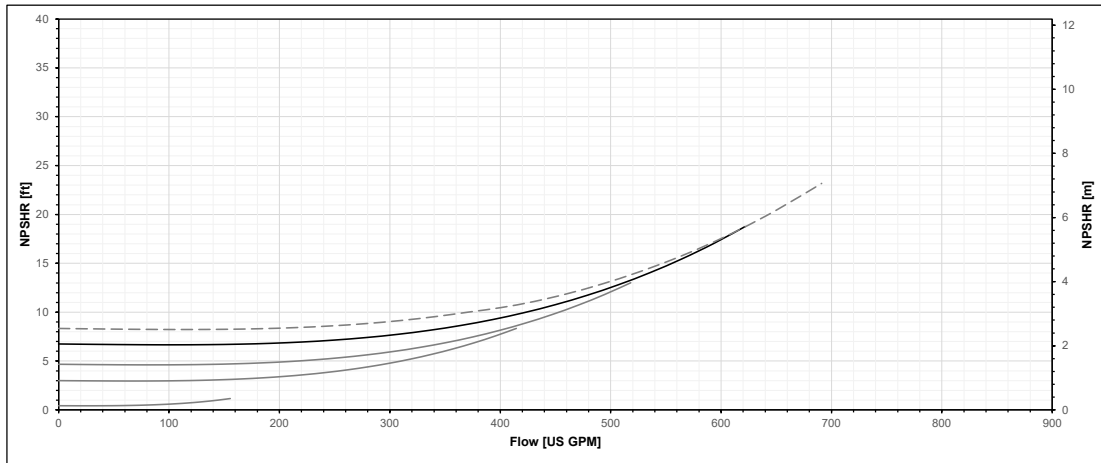
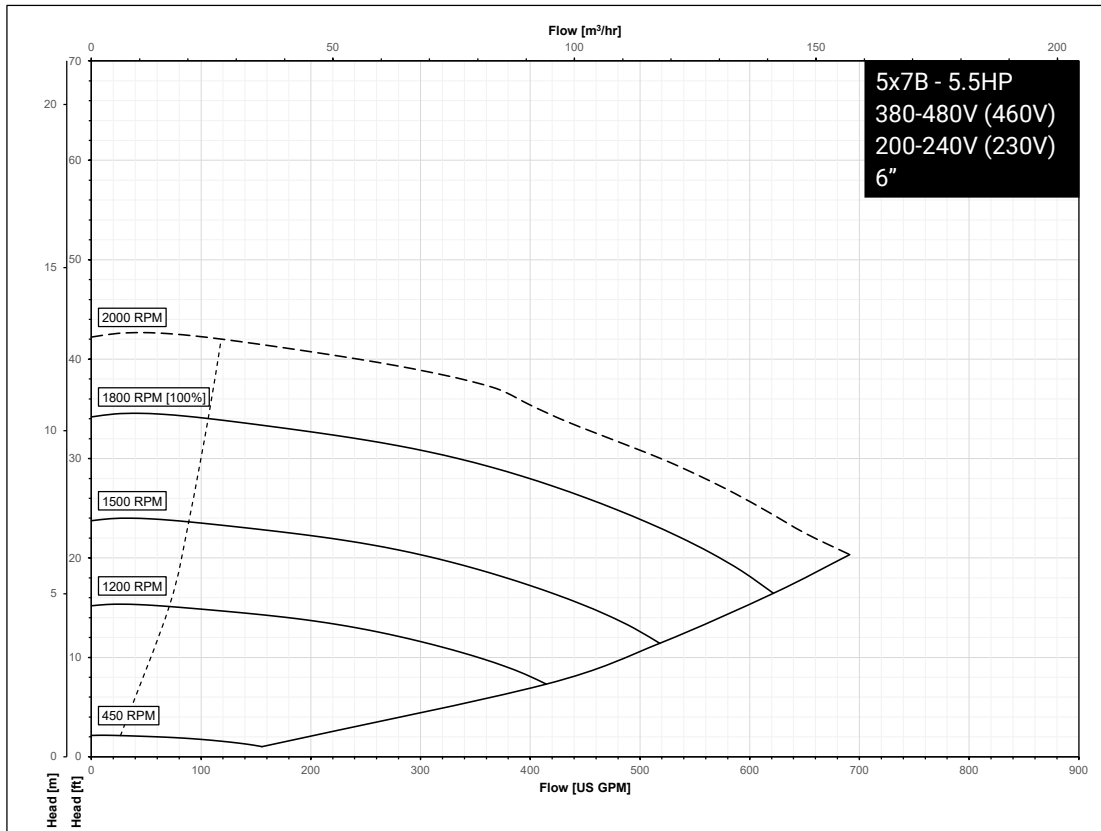

# SERIES e-80X Performance Curves for Low Speed Models

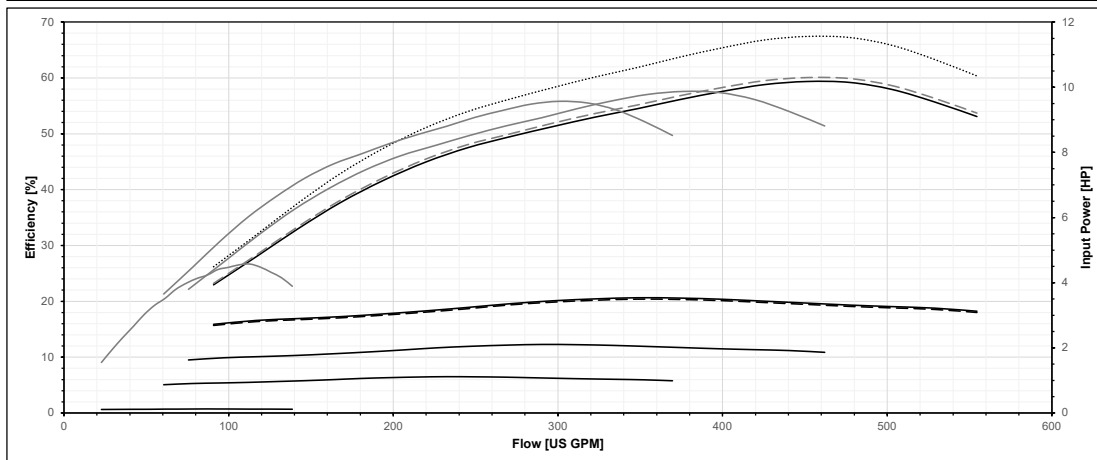
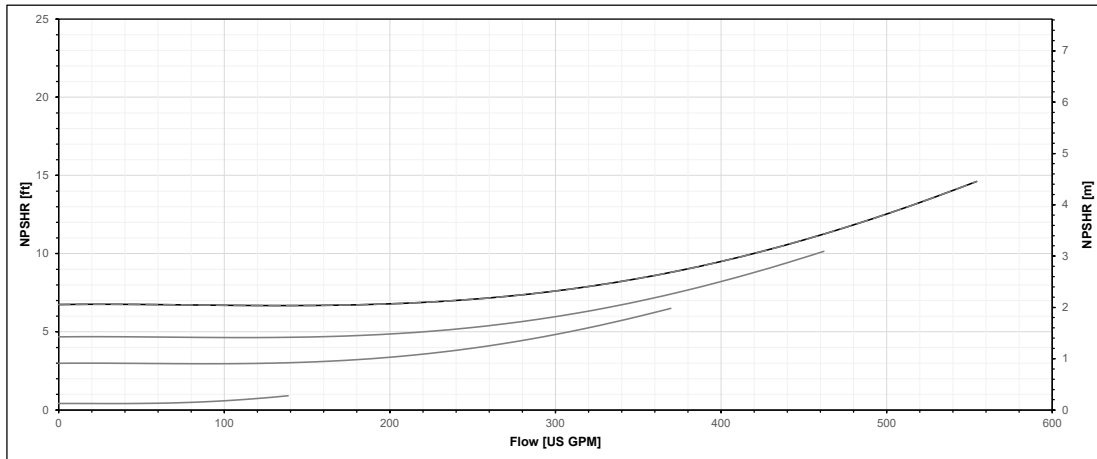
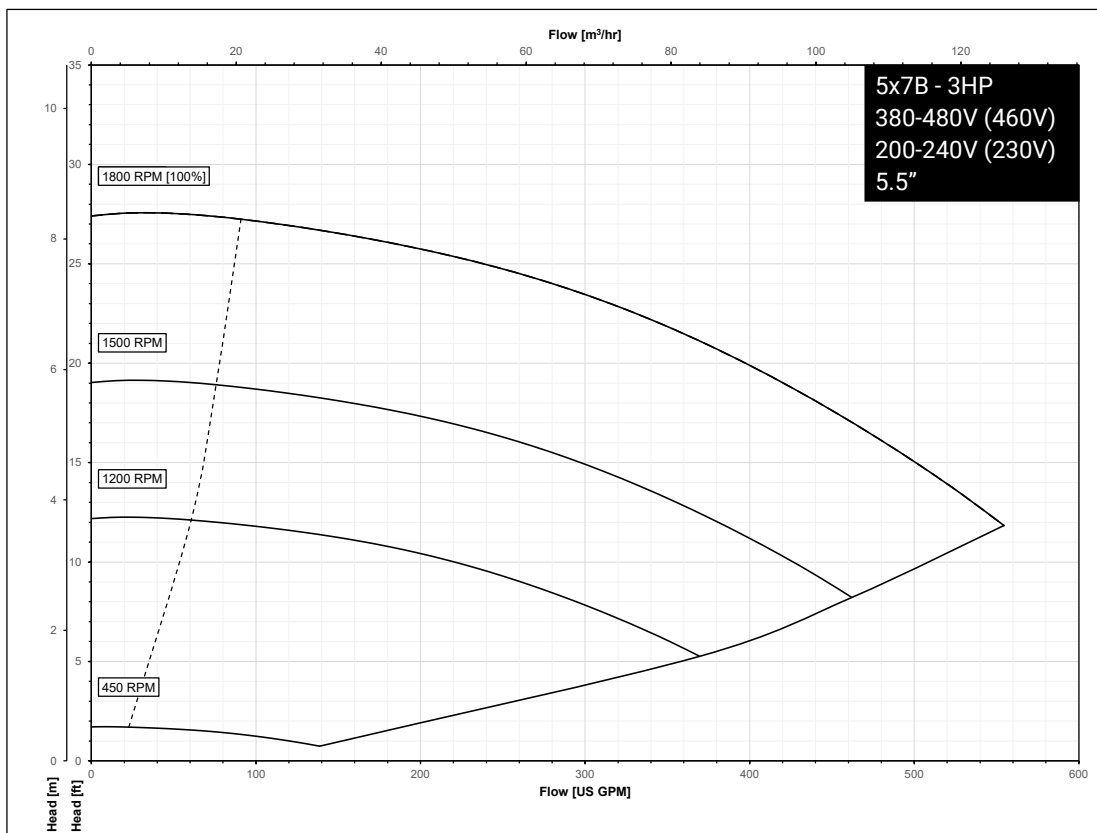

# SERIES e-80X Performance Curves for Low Speed Models

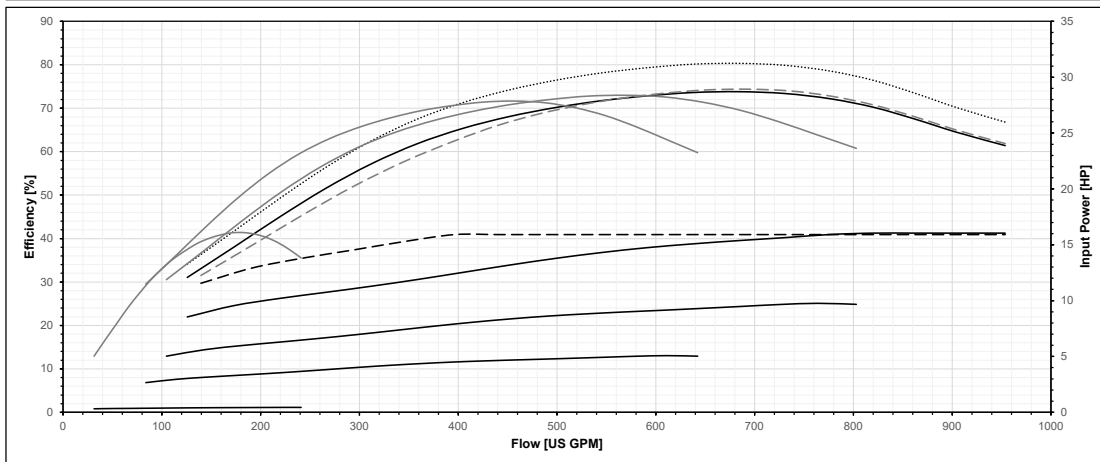
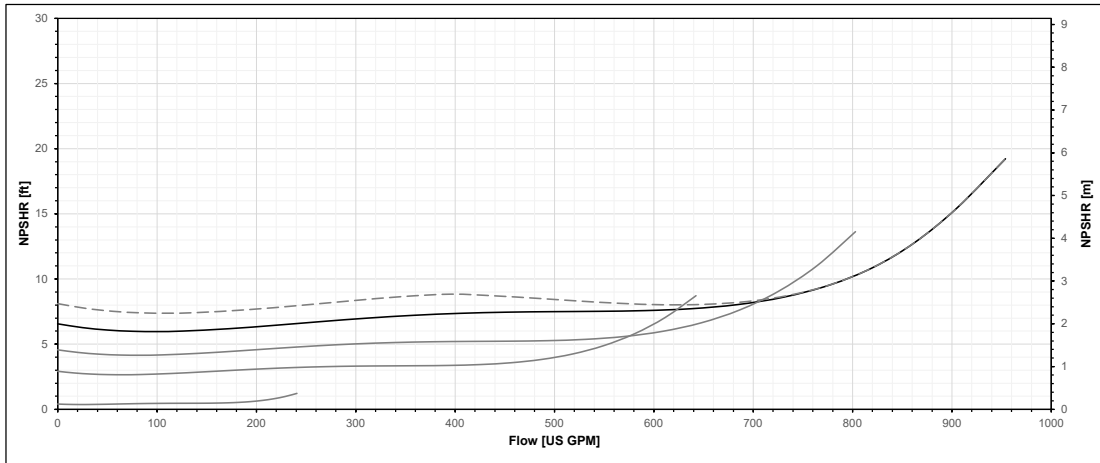
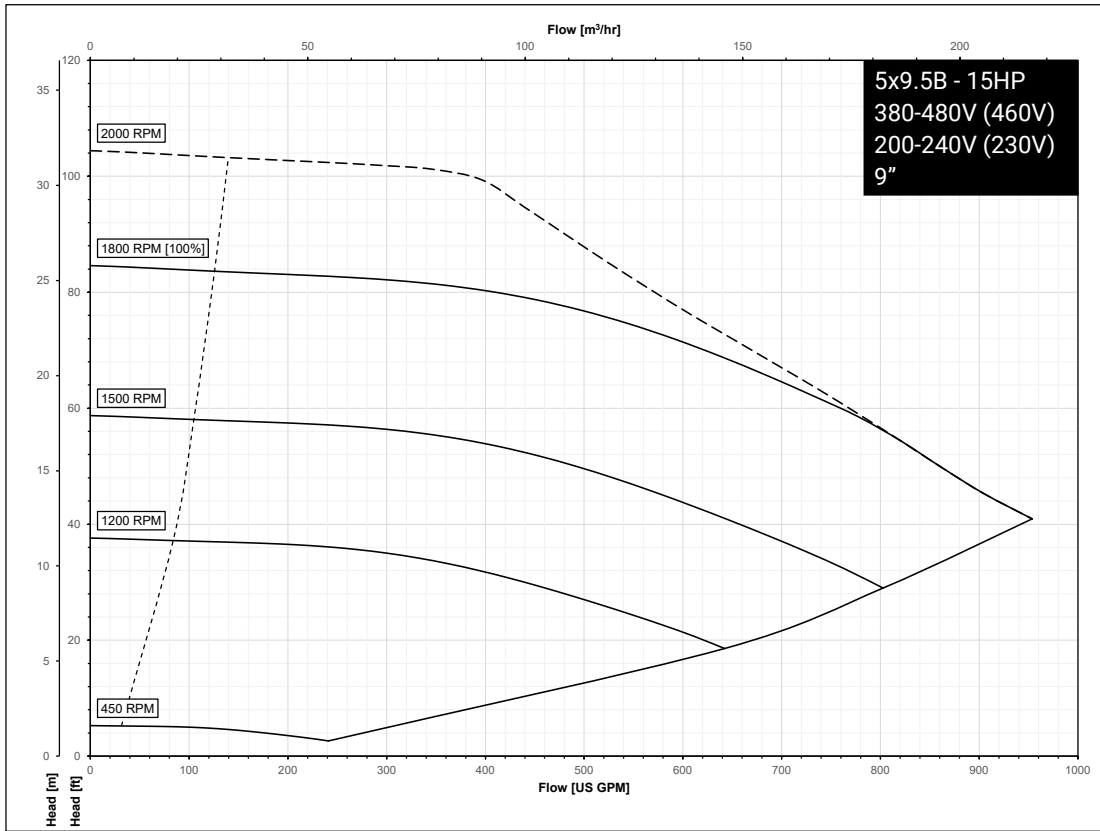

# SERIES e-80X Performance Curves for Low Speed Models

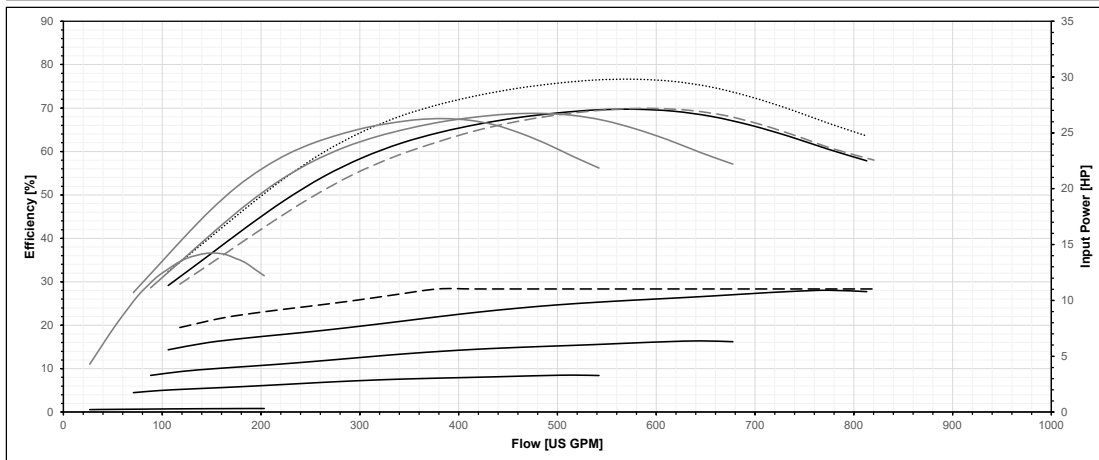
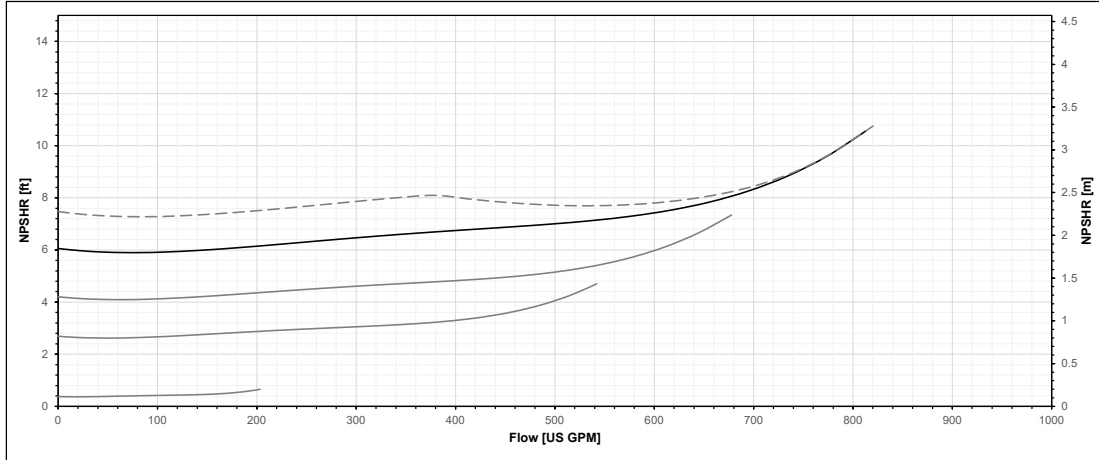
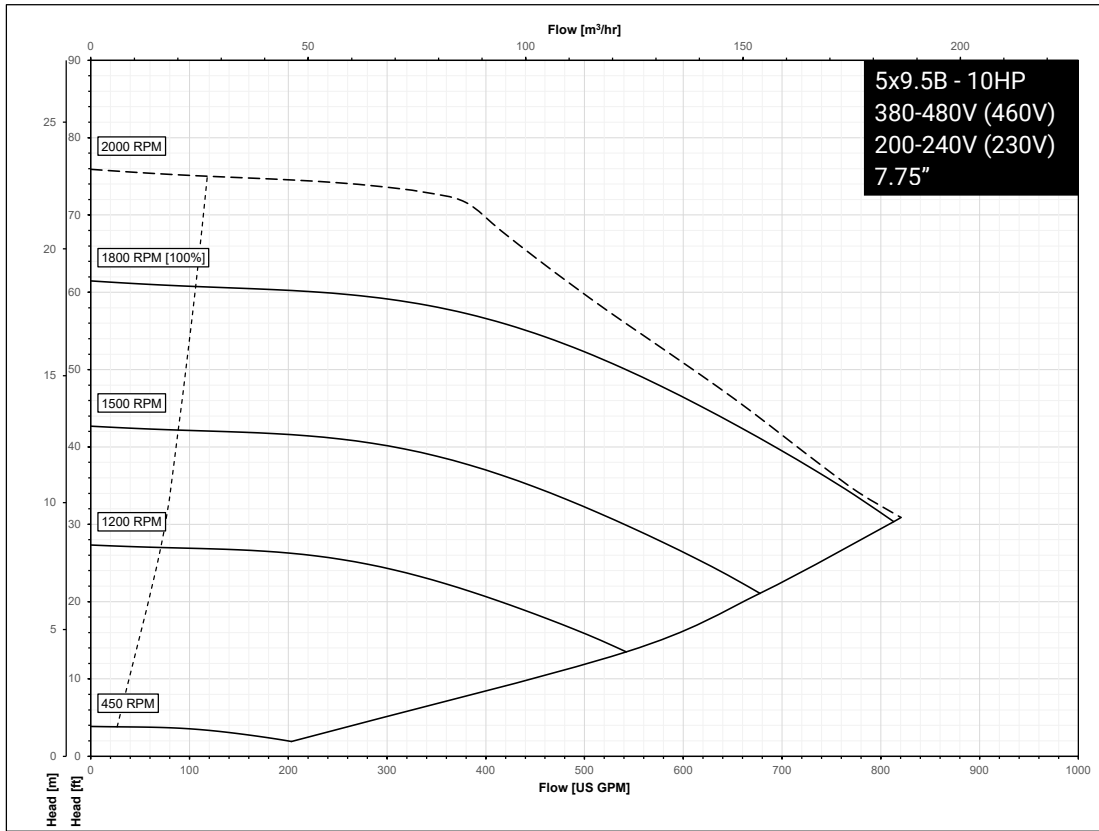

# SERIES e-80X Performance Curves for Low Speed Models

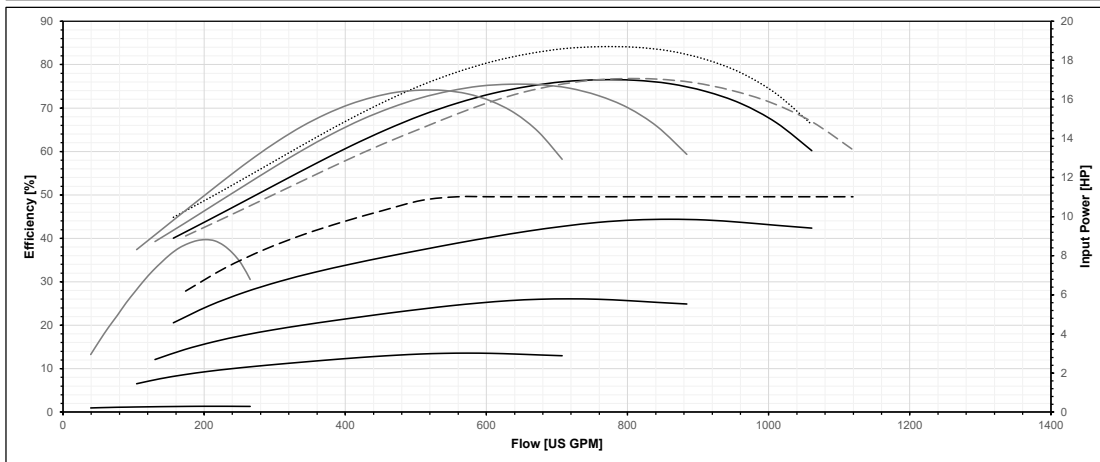
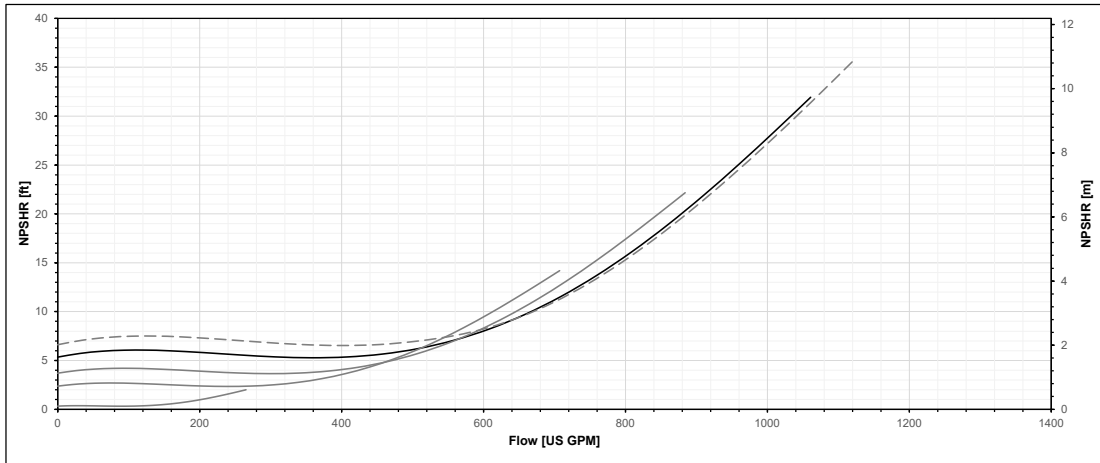
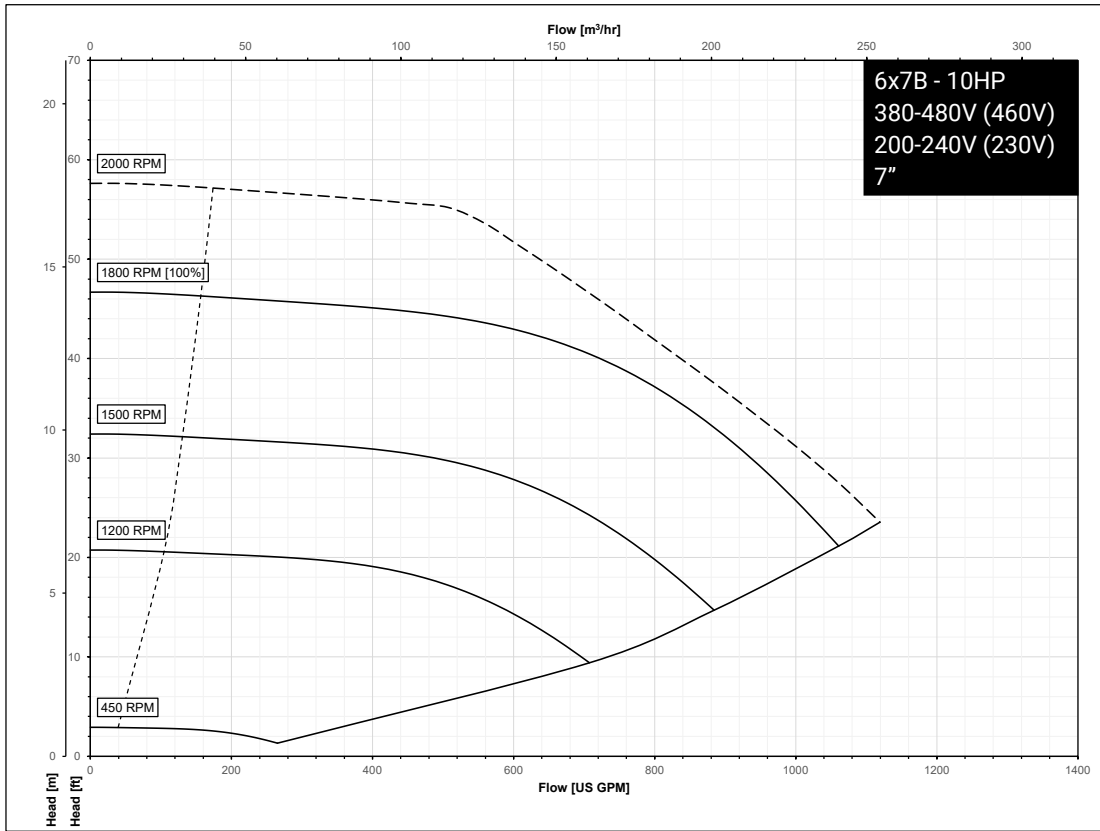

# SERIES e-80X Performance Curves for Low Speed Models

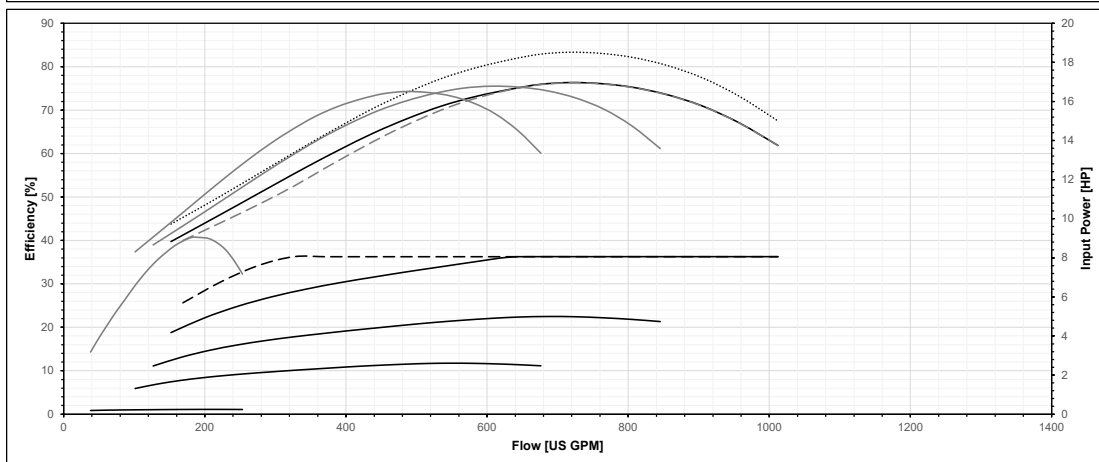
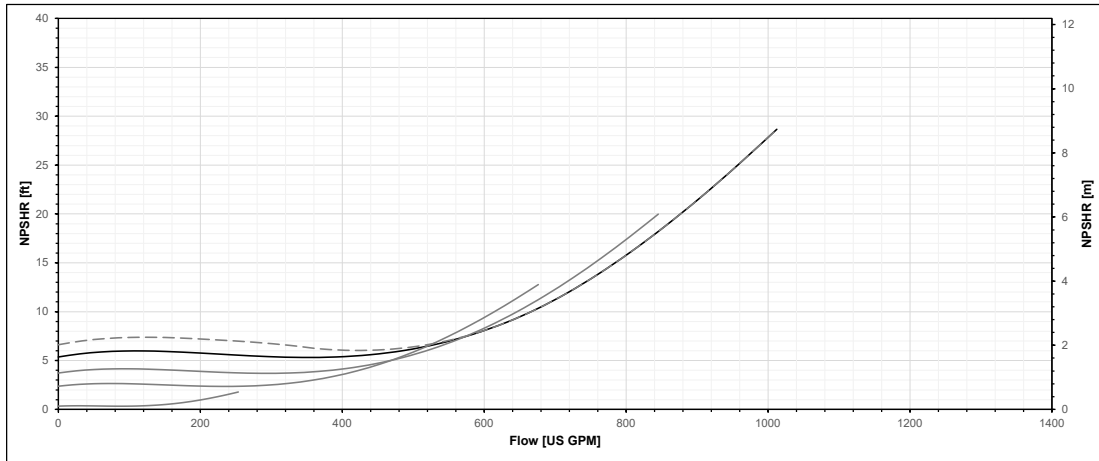
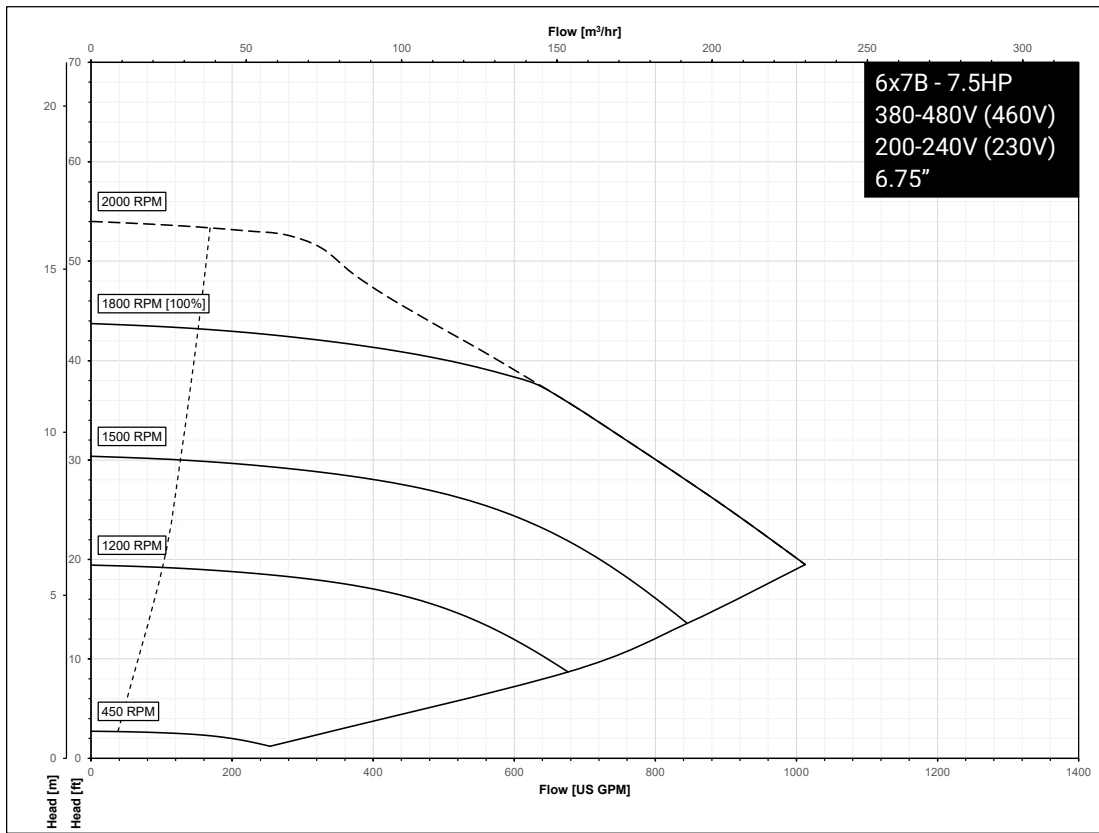

# SERIES e-80X Performance Curves for Low Speed Models

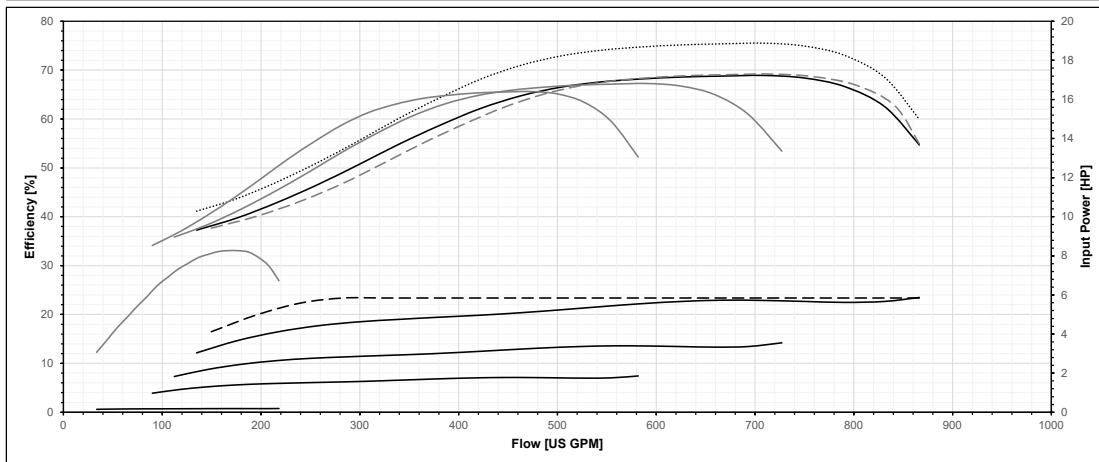
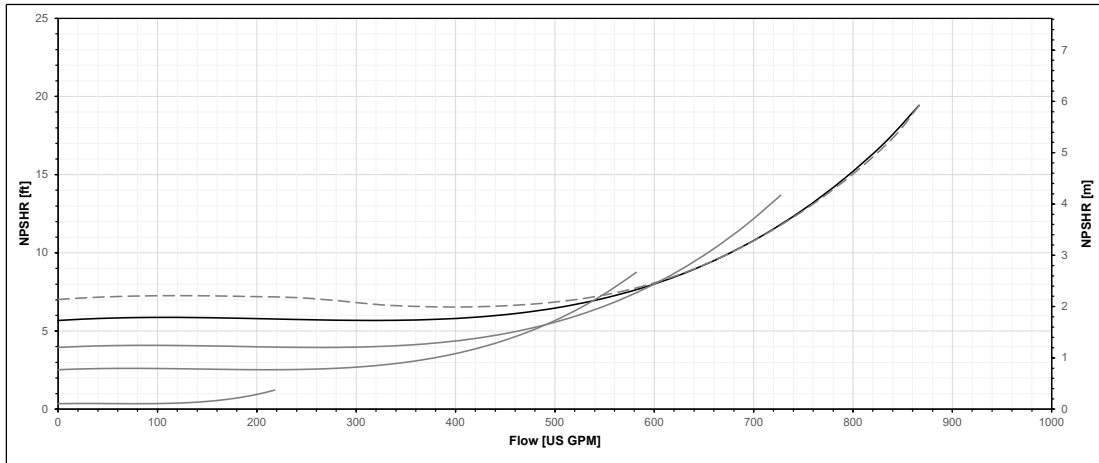
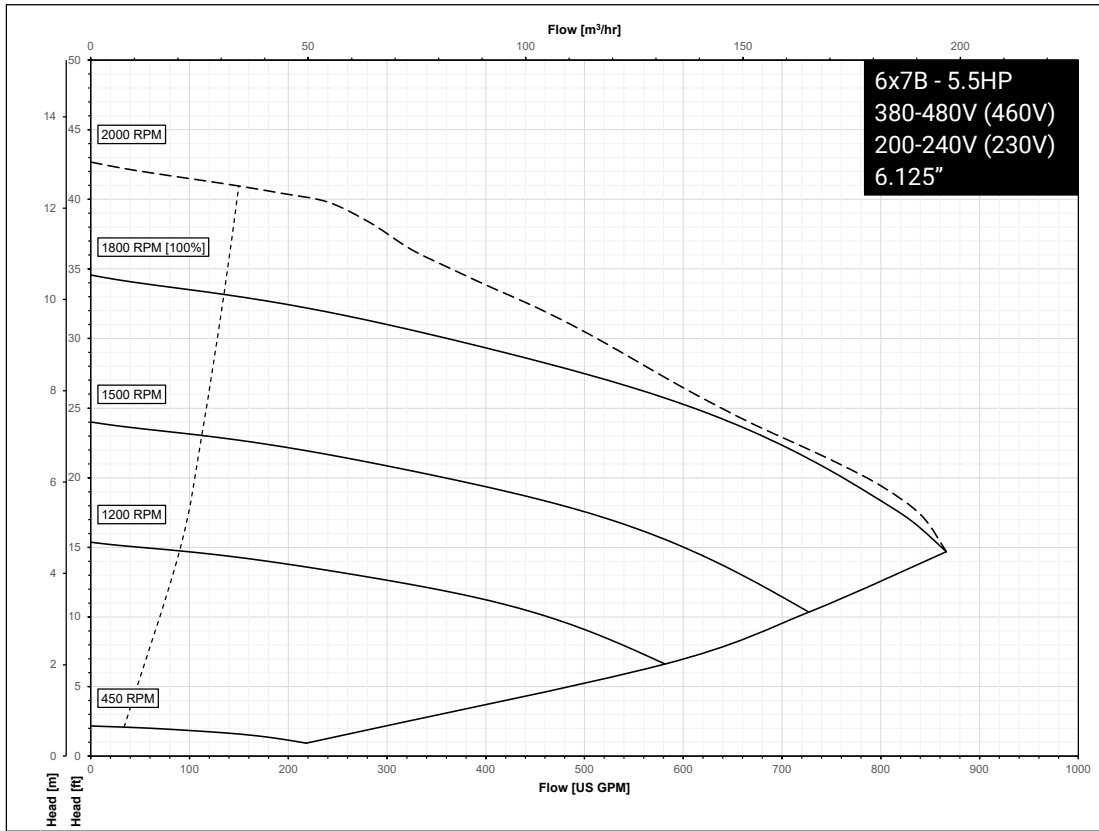

# SERIES e-80X Performance Curves for Low Speed Models

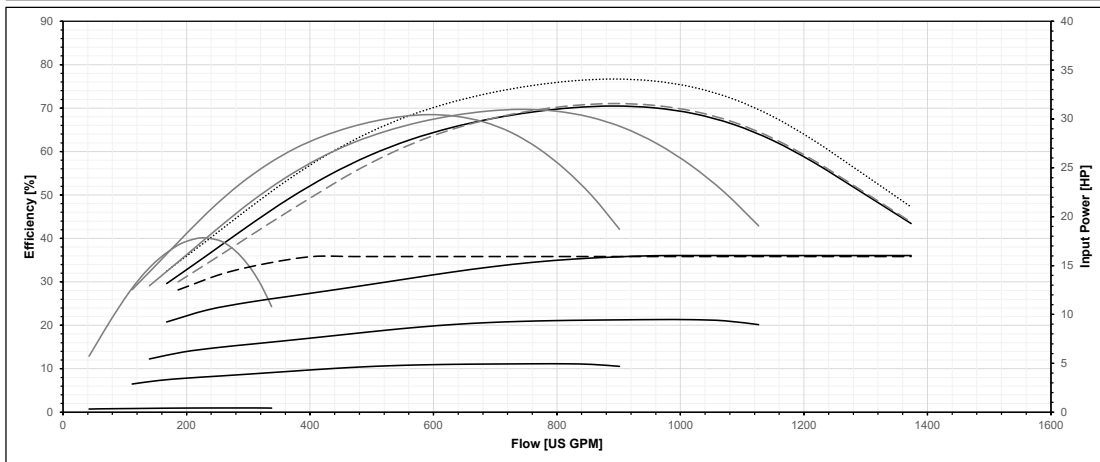
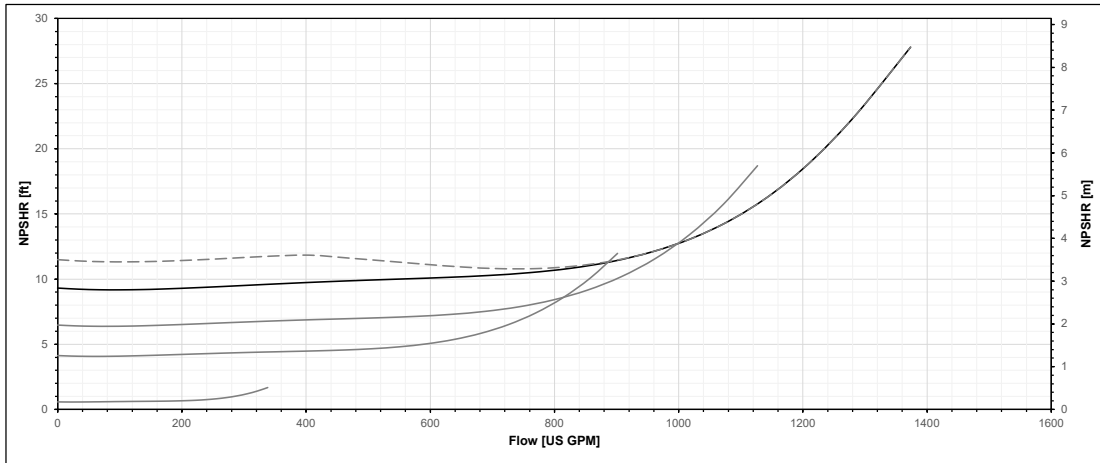
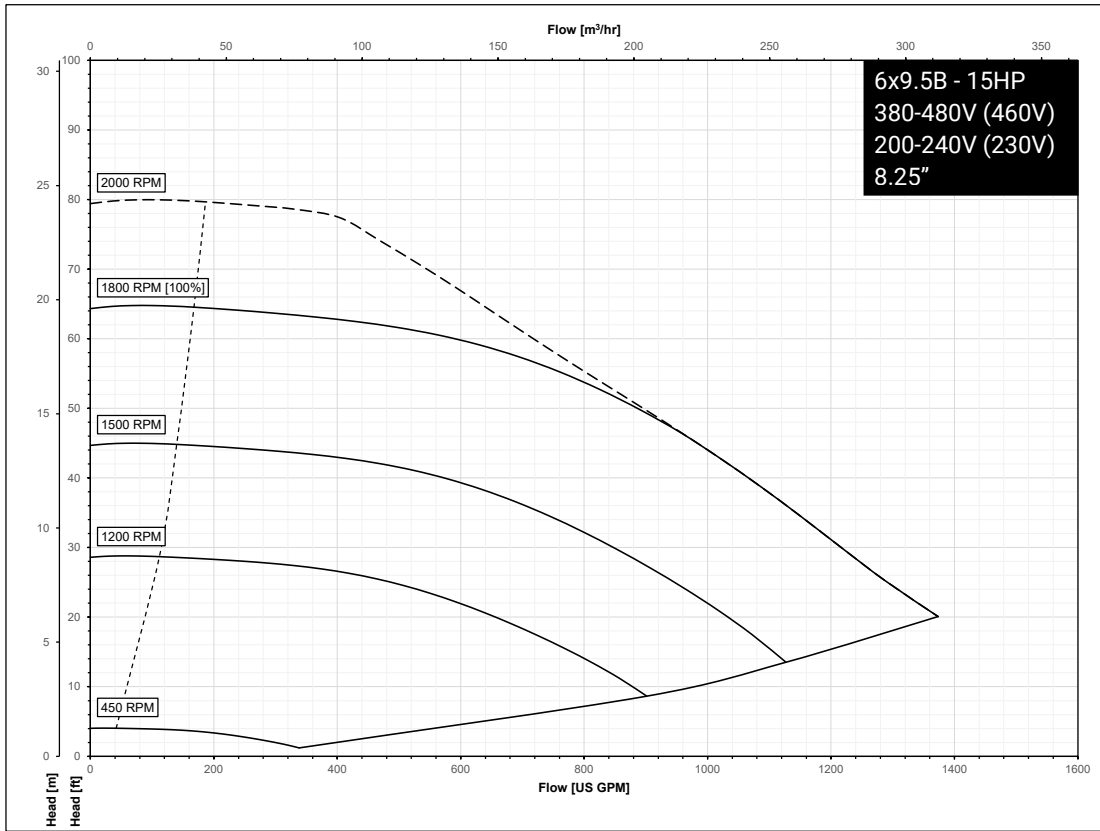

# SERIES e-80X Performance Curves for Low Speed Models

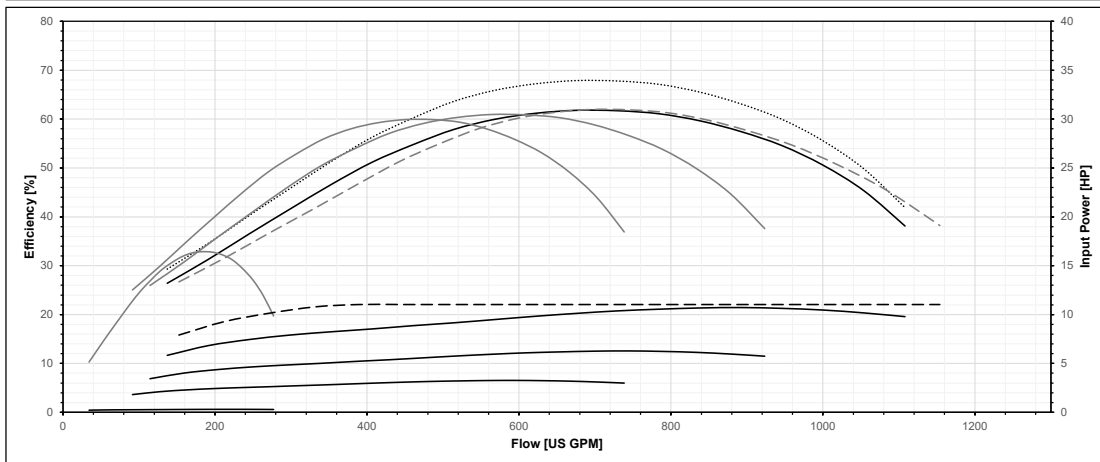
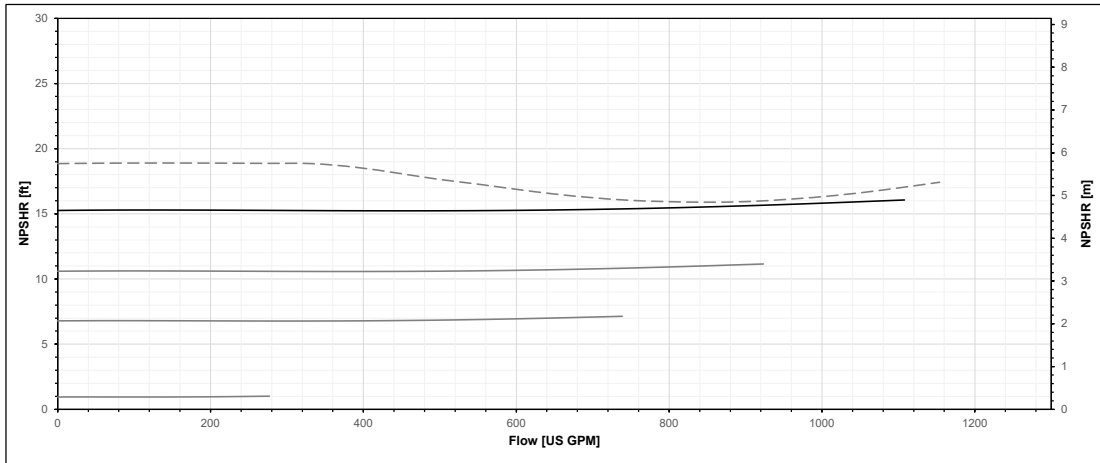
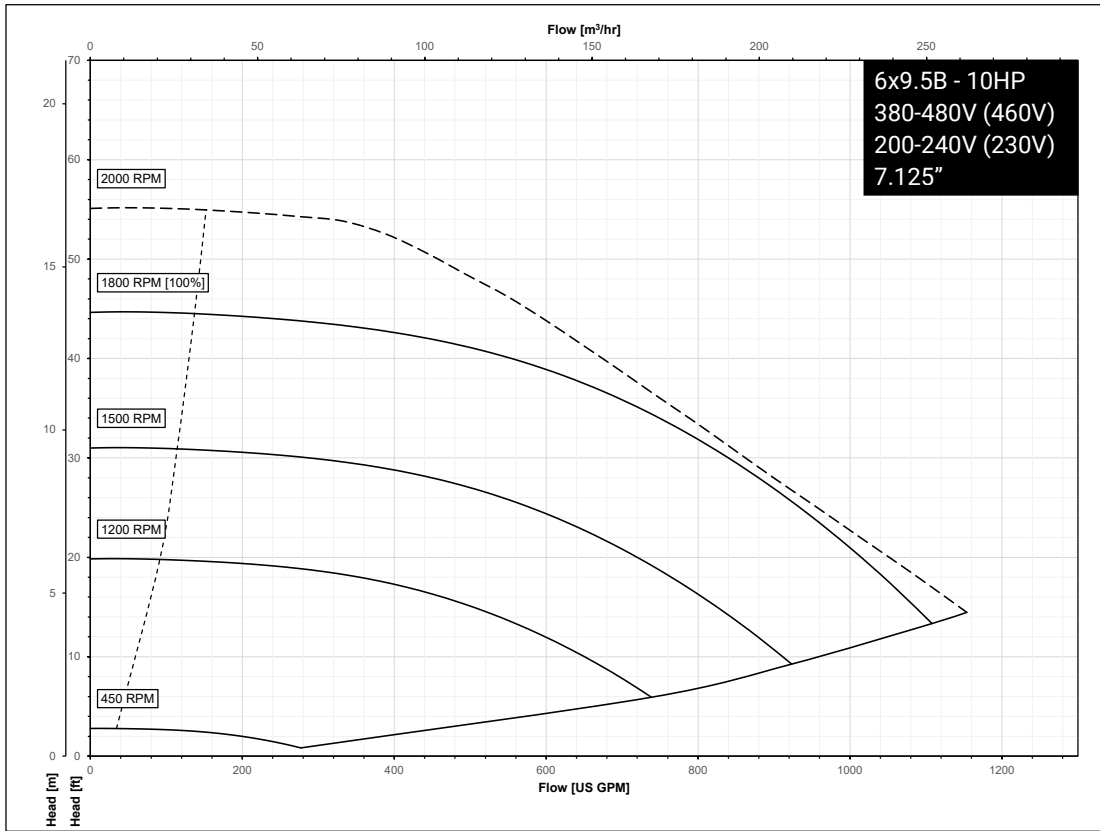

## Materials of Construction

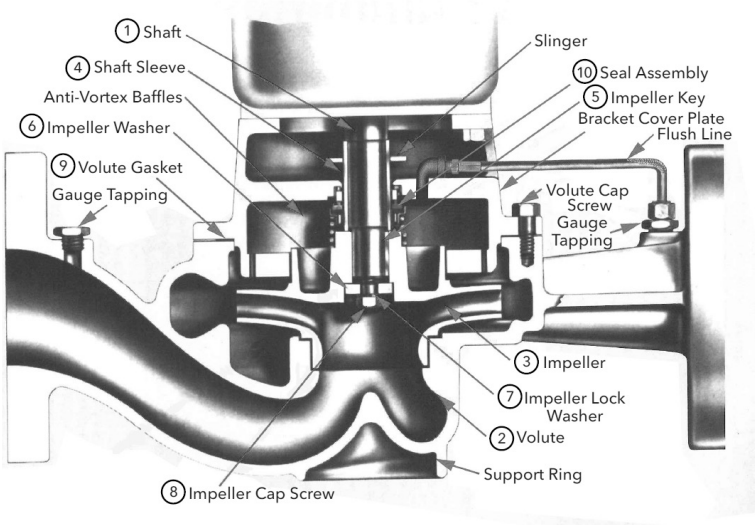

**Standard Mechanical Seal**

#	DESCRIPTION	MATERIAL
1	Shaft	Carbon Steel
2	Volute	Cast Iron ASTM A48 Class B
3	Impeller	ASTM A743 Grade CF8 (304SS)
4	Shaft Sleeve	Stainless Steel
5	Impeller Key	#304 Stainless Steel
6	Impeller Washer	Carbon Steel
7	Impeller Lock Washer	#304 Stainless Steel
8	Impeller Cap Screw	#304 Stainless Steel
9	Volute Gasket	Cellulose Fiber
10	Seal Assemblies	

## Seal Assemblies

### Mechanical Seal Options

OPTIONS	BUNA/Carbon/Ceramic	EPR/C/WC	EPR/SiC/SiC
Temperature	-20 to 225 °F (-29 to 107 °C)	-20 to 250 °F (-29 to 121 °C)	-20 to 250 °F (-29 to 121 °C)
pH Limitations	7.0 - 9.0	7.0 - 11.0	7.0-12.5
Elastomer	BUNA	EPR	EPR
Rotating Face	Carbon	Carbon	Silicon Carbide
Stationary Face	Ceramic	Tungsten Carbide	Silicon Carbide
Hardware	Stainless Steel / Brass	Stainless Steel	Stainless Steel
Max Glycol/Water	50% / 50%	50% / 50%	60% / 40%

# Series e-80X – Dimensions

(All dimensions in inches [mm]. Do not use for construction purposes.)

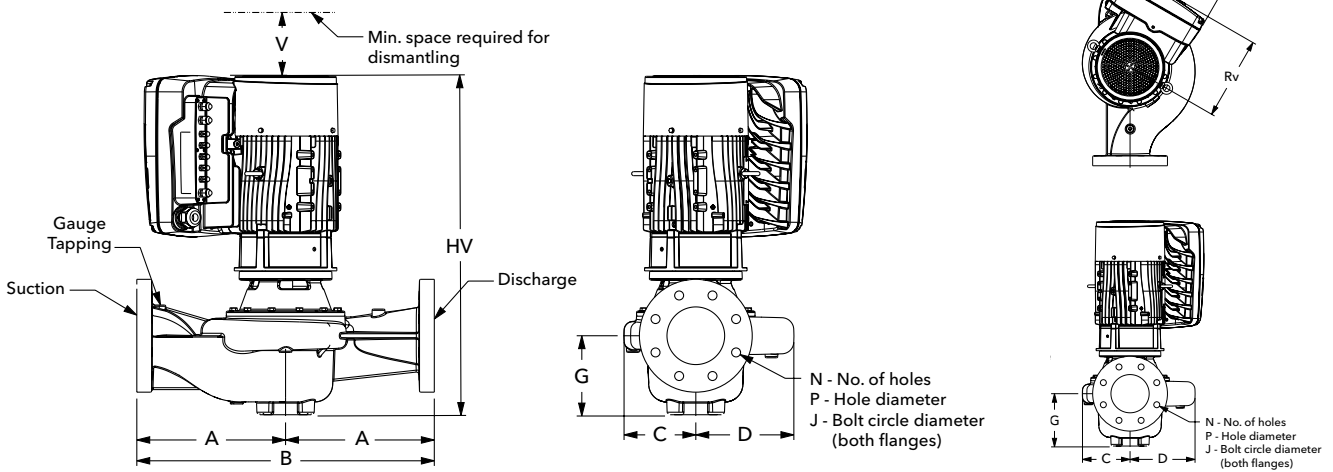

## Dimensions - High speed (380-480V)

Pump Size	Motor Code	e-80X PN	A	B	C	D	G	Hv	V	125# ANSI			Rv	W	Gauge Tappings (NPT)
										J	N	P			
1.5x1.5x7C	130636370	80X157CGMT...	8 [203]	16 [406]	4.57 [116]	4.61 [117]	4.58 [116]	25.35 [644]	5 [127]	3.88 [99]	4 [102]	0.63 [16]	9.48 [241]	11.89 [302]	0.25
1.5x1.5x7C	130636250	80X157VFMT...	8 [203]	16 [406]	4.57 [116]	4.61 [117]	4.58 [116]	25.35 [644]	5 [127]	3.88 [99]	4 [102]	0.63 [16]	9.48 [241]	11.89 [302]	0.25
1.5x1.5x7C	130635410	80X157AEMT...	8 [203]	16 [406]	4.57 [116]	4.61 [117]	4.58 [116]	22.74 [578]	5 [127]	3.88 [99]	4 [102]	0.63 [16]	7.62 [194]	10.1 [257]	0.25
1.5x1.5x9.5B	130637210	80X159JNMT...	9.5 [241]	19 [483]	5.86 [149]	6.16 [156]	4.5 [114]	29.48 [749]	6 [152]	3.88 [99]	4 [102]	0.63 [16]	12.17 [309]	14.25 [362]	0.25
1.5x1.5x9.5B	130637090	80X159JHJT...	9.5 [241]	19 [483]	5.86 [149]	6.16 [156]	4.5 [114]	29.48 [749]	6 [152]	3.88 [99]	4 [102]	0.63 [16]	12.17 [309]	14.25 [362]	0.25
1.5x1.5x9.5B	130636970	80X159GHMT...	9.5 [241]	19 [483]	5.86 [149]	6.16 [156]	4.5 [114]	29.48 [749]	6 [152]	3.88 [99]	4 [102]	0.63 [16]	12.17 [309]	14.25 [362]	0.25
1.5x1.5x9.5B	130636370	80X159GYGT...	9.5 [241]	19 [483]	5.86 [149]	6.16 [156]	4.5 [114]	25.33 [643]	5 [127]	3.88 [99]	4 [102]	0.63 [16]	9.48 [241]	11.89 [302]	0.25
2x2x7B	130636970	80X207CHMT...	8.5 [216]	17 [432]	4.65 [118]	5.12 [130]	5.13 [130]	30.57 [777]	6 [152]	4.75 [121]	4 [102]	0.75 [19]	12.17 [309]	14.25 [362]	0.25
2x2x7B	130636370	80X207VGMT...	8.5 [216]	17 [432]	4.65 [118]	5.12 [130]	5.13 [130]	25.71 [653]	5 [127]	4.75 [121]	4 [102]	0.75 [19]	9.48 [241]	11.89 [302]	0.25
2x2x7B	130636250	80X207AFMT...	8.5 [216]	17 [432]	4.65 [118]	5.12 [130]	5.13 [130]	25.71 [653]	5 [127]	4.75 [121]	4 [102]	0.75 [19]	9.48 [241]	11.89 [302]	0.25
2x2x7B	130635410	80X207NEMT...	8.5 [216]	17 [432]	4.65 [118]	5.12 [130]	5.13 [130]	23.27 [591]	5 [127]	4.75 [121]	4 [102]	0.75 [19]	7.62 [194]	10.1 [257]	0.25
2x2x9.5C	130637210	80X209GNMT...	10 [254]	20 [508]	6 [152]	6.5 [165]	5.38 [137]	30.42 [773]	6 [152]	4.75 [121]	4 [102]	0.75 [19]	12.17 [309]	14.25 [362]	0.25
2.5x2.5x7B	130636970	80X257CHMT...	9 [229]	18 [457]	4.7 [119]	5.46 [139]	5.4 [137]	35.08 [891]	6 [152]	5.5 [140]	4 [102]	0.75 [19]	12.17 [309]	14.25 [362]	0.25
2.5x2.5x7B	130636370	80X257VGMT...	9 [229]	18 [457]	4.7 [119]	5.46 [139]	5.4 [137]	26.26 [667]	5 [127]	5.5 [140]	4 [102]	0.75 [19]	9.48 [241]	11.89 [302]	0.25
2.5x2.5x7B	130636250	80X257AFMT...	9 [229]	18 [457]	4.7 [119]	5.46 [139]	5.4 [137]	26.26 [667]	5 [127]	5.5 [140]	4 [102]	0.75 [19]	9.48 [241]	11.89 [302]	0.25
2.5x2.5x7B	130635410	80X257NEMT...	9 [229]	18 [457]	4.7 [119]	5.46 [139]	5.4 [137]	23.81 [605]	5 [127]	5.5 [140]	4 [102]	0.75 [19]	7.62 [194]	10.1 [257]	0.25
2.5x2.5x9.5C	130637210	80X259ENMT...	10.75 [273]	21.5 [546]	5.96 [151]	7.06 [179]	6 [152]	31.1 [790]	6 [152]	5.5 [140]	4 [102]	0.75 [19]	12.17 [309]	14.25 [362]	0.25
3x3x7C	130637210	80X307CNMT...	9.5 [241]	19 [483]	4.98 [126]	6.25 [159]	5.85 [149]	31.02 [788]	6 [152]	6 [152]	4 [102]	0.75 [19]	12.17 [309]	14.25 [362]	0.25
3x3x7C	130637090	80X307CJMT...	9.5 [241]	19 [483]	4.98 [126]	6.25 [159]	5.85 [149]	31.02 [788]	6 [152]	6 [152]	4 [102]	0.75 [19]	12.17 [309]	14.25 [362]	0.25
3x3x7C	130636370	80X307QGMT...	9.5 [241]	19 [483]	4.98 [126]	6.25 [159]	5.85 [149]	26.87 [682]	5 [127]	6 [152]	4 [102]	0.75 [19]	9.48 [241]	11.89 [302]	0.25

### Dimensions - High speed (380-480V) (Continued)

Pump Size	Motor Code	e-80X PN	A	B	C	D	G	Hv	V	125# ANSI			Rv	W	Gauge Tappings (NPT)
										J	N	P			
3x3x9.5C	130637210	80X309DNMT...	11.5 [292]	23 [584]	6.53 [166]	7.4 [188]	6.13 [156]	31.23 [793]	6 [152]	6 [152]	4 [102]	0.75 [19]	12.17 [309]	14.25 [362]	0.25
3x3x11B	130637210	80X301ENMT...	12 [305]	24 [610]	6.99 [178]	7.13 [181]	6.75 [171]	30.71 [780]	6 [152]	6 [152]	4 [102]	0.75 [19]	12.17 [309]	14.25 [362]	0.25
4x4x7B	130637210	80X407BNMT...	10.5 [267]	21 [533]	5.28 [134]	6.53 [166]	6.57 [167]	31.99 [813]	6 [152]	7.5 [191]	8 [203]	0.75 [19]	12.17 [309]	14.25 [362]	0.25
4x4x7B	130637090	80X407AJMT...	10.5 [267]	21 [533]	5.28 [134]	6.53 [166]	6.57 [167]	31.99 [813]	6 [152]	7.5 [191]	8 [203]	0.75 [19]	12.17 [309]	14.25 [362]	0.25
5x5x7B	130637210	80X507QNMT...	12 [305]	24 [610]	5.69 [145]	8.31 [211]	7.28 [185]	33.07 [840]	6 [152]	8.5 [216]	8 [203]	0.88 [22]	12.17 [309]	14.25 [362]	0.25
6x6x7B	130637210	80X607QNMT...	14 [356]	28 [711]	6.5 [165]	8.5 [216]	8.13 [207]	34.48 [876]	6 [152]	9.5 [241]	8 [203]	0.88 [22]	12.17 [309]	14.25 [362]	0.25

### Series e-80X – Dimensions

(All dimensions in inches [mm]. Do not use for construction purposes.)

### Dimensions - High speed (200-240V)

Pump Size	Motor Code	e-80X PN	A	B	C	D	G	Hv	V	125# ANSI			Rv	W	Gauge Tappings (NPT)
										J	N	P			
1.5x1.5x7C	130637691	80X157AEMS...	8 [203]	16 [406]	4.57 [116]	4.61 [117]	4.58 [116]	25.35 [644]	5 [127]	3.88 [99]	4 [102]	0.63 [16]	9.48 [241]	11.89 [302]	0.25
1.5x1.5x9.5B	130636971	80X159GHMS...	9.5 [241]	19 [483]	5.86 [149]	6.16 [156]	4.5 [114]	29.48 [749]	6 [152]	3.88 [99]	4 [102]	0.63 [16]	12.17 [309]	14.25 [362]	0.25
1.5x1.5x9.5B	130637771	80X159YGMS...	9.5 [241]	19 [483]	5.86 [149]	6.16 [156]	4.5 [114]	29.48 [749]	6 [152]	3.88 [99]	4 [102]	0.63 [16]	12.17 [309]	14.25 [362]	0.25
2x2x7B	130636971	80X207CHMS...	8.5 [216]	17 [432]	4.65 [118]	5.12 [130]	5.13 [130]	30.57 [777]	6 [152]	4.75 [121]	4 [102]	0.75 [19]	12.17 [309]	14.25 [362]	0.25
2x2x7B	130637771	80X207VGMS...	8.5 [216]	17 [432]	4.65 [118]	5.12 [130]	5.13 [130]	30.57 [777]	6 [152]	4.75 [121]	4 [102]	0.75 [19]	12.17 [309]	14.25 [362]	0.25
2x2x7B	130637691	80X207NEMS...	8.5 [216]	17 [432]	4.65 [118]	5.12 [130]	5.13 [130]	25.71 [653]	5 [127]	4.75 [121]	4 [102]	0.75 [19]	9.48 [241]	11.89 [302]	0.25
2x2x9.5C	130636971	80X209DHMS...	10 [254]	20 [508]	6 [152]	6.5 [165]	5.38 [137]	30.42 [773]	6 [152]	4.75 [121]	4 [102]	0.75 [19]	12.17 [309]	14.25 [362]	0.25
2.5x2.5x7B	130636971	80X257CHMS...	9 [229]	18 [457]	4.7 [119]	5.46 [139]	5.4 [137]	30.57 [777]	6 [152]	5.5 [140]	4 [102]	0.75 [19]	12.17 [309]	14.25 [362]	0.25
2.5x2.5x7B	130637771	80X257VGMS...	9 [229]	18 [457]	4.7 [119]	5.46 [139]	5.4 [137]	30.57 [777]	6 [152]	5.5 [140]	4 [102]	0.75 [19]	12.17 [309]	14.25 [362]	0.25
2.5x2.5x7B	130637691	80X257NEMS...	9 [229]	18 [457]	4.7 [119]	5.46 [139]	5.4 [137]	26.26 [667]	5 [127]	5.5 [140]	4 [102]	0.75 [19]	9.48 [241]	11.89 [302]	0.25
3x3x7C	130636971	80X307BHMS...	9.5 [241]	19 [483]	4.98 [126]	6.25 [159]	5.85 [149]	31.02 [788]	6 [152]	6 [152]	4 [102]	0.75 [19]	12.17 [309]	14.25 [362]	0.25
3x3x7C	130637771	80X307QGMS...	9.5 [241]	19 [483]	4.98 [126]	6.25 [159]	5.85 [149]	31.02 [788]	6 [152]	6 [152]	4 [102]	0.75 [19]	12.17 [309]	14.25 [362]	0.25
4x4x7B	130636971	80X407RHMS...	10.5 [267]	21 [533]	5.28 [134]	6.53 [166]	6.57 [167]	31.99 [813]	6 [152]	7.5 [191]	8 [203]	0.75 [19]	12.17 [309]	14.25 [362]	0.25
5x5x7B	130636971	80X507PHMS...	12 [305]	24 [610]	5.69 [145]	8.31 [211]	7.28 [185]	33.07 [840]	6 [152]	8.5 [216]	8 [203]	0.88 [22]	12.17 [309]	14.25 [362]	0.25

## Dimensions - Low speed (380-480V)

Pump Size	Motor Code	e-80X PN	A	B	C	D	G	Hv	V	125# ANSI			Rv	W	Gauge Tappings (NPT)
										J	N	P			
1.5x1.5x7C	130635810	80X157CBLT...	8 [203]	16 [406]	4.57 [116]	4.61 [117]	4.58 [116]	22.74 [578]	5 [127]	3.88 [99]	4 [102]	0.63 [16]	7.62 [194]	10.1 [257]	0.25
1.5x1.5x9.5B	130636610	80X159JDLT...	9.5 [241]	19 [483]	5.86 [149]	6.16 [156]	4.5 [114]	25.33 [643]	5 [127]	3.88 [99]	4 [102]	0.63 [16]	9.48 [241]	11.89 [302]	0.25
1.5x1.5x9.5B	130635810	80X159GBLT...	9.5 [241]	19 [483]	5.86 [149]	6.16 [156]	4.5 [114]	22.72 [577]	5 [127]	3.88 [99]	4 [102]	0.63 [16]	7.62 [194]	10.1 [257]	0.25
2x2x7B	130635810	80X207CBLT...	8.5 [216]	17 [432]	4.65 [118]	5.12 [130]	5.13 [130]	23.27 [591]	5 [127]	4.75 [121]	4 [102]	0.75 [19]	7.62 [194]	10.1 [257]	0.25
2x2x9.5C	130636730	80X209JELT...	10 [254]	20 [508]	6 [152]	6.5 [165]	5.38 [137]	26.27 [667]	5 [127]	4.75 [121]	4 [102]	0.75 [19]	9.48 [241]	11.89 [302]	0.25
2x2x9.5C	130635810	80X209EBLT...	10 [254]	20 [508]	6 [152]	6.5 [165]	5.38 [137]	23.70 [602]	5 [127]	4.75 [121]	4 [102]	0.75 [19]	7.62 [194]	10.1 [257]	0.25
2.5x2.5x7B	130635810	80X257CBLT...	9 [229]	18 [457]	4.7 [119]	5.46 [139]	5.4 [137]	23.81 [605]	5 [127]	5.5 [140]	4 [102]	0.75 [19]	7.62 [194]	10.1 [257]	0.25
2.5x2.5x9.5C	130636730	80X259JELT...	10.75 [273]	21.5 [546]	5.96 [151]	7.06 [179]	6 [152]	26.95 [685]	5 [127]	5.5 [140]	4 [102]	0.75 [19]	9.48 [241]	11.89 [302]	0.25
2.5x2.5x9.5C	130636610	80X259EDLT...	10.75 [273]	21.5 [546]	5.96 [151]	7.06 [179]	6 [152]	26.95 [685]	5 [127]	5.5 [140]	4 [102]	0.75 [19]	9.48 [241]	11.89 [302]	0.25
2.5x2.5x9.5C	130635810	80X259CBLT...	10.75 [273]	21.5 [546]	5.96 [151]	7.06 [179]	6 [152]	24.33 [618]	5 [127]	5.5 [140]	4 [102]	0.75 [19]	7.62 [194]	10.1 [257]	0.25
3x3x7C	130637730	80X307CCLT...	9.5 [241]	19 [483]	4.98 [126]	6.25 [159]	5.85 [149]	26.87 [682]	5 [127]	6 [152]	4 [102]	0.75 [19]	9.48 [241]	11.89 [302]	0.25
3x3x7C	130635810	80X307CBLT...	9.5 [241]	19 [483]	4.98 [126]	6.25 [159]	5.85 [149]	224.26 [616]	5 [127]	6 [152]	4 [102]	0.75 [19]	7.62 [194]	10.1 [257]	0.25
3x3x9.5C	130638390	80X309JFLT...	11.5 [292]	23 [584]	6.53 [166]	7.4 [188]	6.13 [156]	31.23 [793]	6 [152]	6 [152]	4 [102]	0.75 [19]	12.17 [309]	14.25 [362]	0.25
3x3x9.5C	130636730	80X309GELT...	11.5 [292]	23 [584]	6.53 [166]	7.4 [188]	6.13 [156]	26.93 [684]	5 [127]	6 [152]	4 [102]	0.75 [19]	9.48 [241]	11.89 [302]	0.25
3x3x9.5C	130636610	80X309YDLT...	11.5 [292]	23 [584]	6.53 [166]	7.4 [188]	6.13 [156]	26.93 [684]	5 [127]	6 [152]	4 [102]	0.75 [19]	9.48 [241]	11.89 [302]	0.25
3x3x11B	130637570	80X301LGLT...	12 [305]	24 [610]	6.99 [178]	7.13 [181]	6.75 [171]	30.71 [780]	6 [152]	6 [152]	4 [102]	0.75 [19]	12.17 [309]	14.25 [362]	0.25
3x3x11B	130638390	80X301KFLT...	12 [305]	24 [610]	6.99 [178]	7.13 [181]	6.75 [171]	30.71 [780]	6 [152]	6 [152]	4 [102]	0.75 [19]	12.17 [309]	14.25 [362]	0.25
3x3x11B	130636730	80X3019ELT...	12 [305]	24 [610]	6.99 [178]	7.13 [181]	6.75 [171]	27.40 [696]	6 [152]	6 [152]	4 [102]	0.75 [19]	9.48 [241]	11.89 [302]	0.25
4x4x7B	130636610	80X407CDLT...	10.5 [267]	21 [533]	5.28 [134]	6.53 [166]	6.57 [167]	27.84 [707]	5 [127]	7.5 [191]	8 [203]	0.75 [19]	9.48 [241]	11.89 [302]	0.25
4x4x7B	130635810	80X407ABLT...	10.5 [267]	21 [533]	5.28 [134]	6.53 [166]	6.57 [167]	25.2 [640]	5 [127]	7.5 [191]	8 [203]	0.75 [19]	7.62 [194]	10.1 [257]	0.25
4x4x9.5B	130637570	80X409JGLT...	12.5 [318]	25 [635]	6.51 [165]	7.94 [202]	7.25 [184]	32.67 [830]	6 [152]	7.5 [191]	8 [203]	0.75 [19]	12.17 [309]	14.25 [362]	0.25
4x4x9.5B	130638390	80X409GFLT...	12.5 [318]	25 [635]	6.51 [165]	7.94 [202]	7.25 [184]	32.67 [830]	6 [152]	7.5 [191]	8 [203]	0.75 [19]	12.17 [309]	14.25 [362]	0.25
4x4x9.5B	130636730	80X409YELT...	12.5 [318]	25 [635]	6.51 [165]	7.94 [202]	7.25 [184]	28.40 [720]	6 [152]	7.5 [191]	8 [203]	0.75 [19]	9.48 [241]	11.89 [302]	0.25
4x4x11	130637570	80X401KGLT...	13 [330]	26 [660]	7.01 [178]	8.22 [209]	7.5 [191]	31.65 [804]	6 [152]	7.5 [191]	8 [203]	0.75 [19]	12.17 [309]	14.25 [362]	0.25
4x4x11	130638390	80X401HFLT...	13 [330]	26 [660]	7.01 [178]	8.22 [209]	7.5 [191]	31.65 [804]	6 [152]	7.5 [191]	8 [203]	0.75 [19]	12.17 [309]	14.25 [362]	0.25

## Dimensions - Low speed (380-480V) (Continued)

Pump Size	Motor Code	e-80X PN	A	B	C	D	G	Hv	V	125# ANSI			Rv	W	Gauge Tappings (NPT)
										J	N	P			
5x5x7B	130636730	80X507CELT...	12 [305]	24 [610]	5.69 [145]	8.31 [211]	7.28 [185]	28.92 [735]	5 [127]	8.5 [216]	8 [203]	0.88 [22]	9.48 [241]	11.89 [302]	0.25
5x5x7B	130636610	80X507ADLT...	12 [305]	24 [610]	5.69 [145]	8.31 [211]	7.28 [185]	28.92 [735]	5 [127]	8.5 [216]	8 [203]	0.88 [22]	9.48 [241]	11.89 [302]	0.25
5x5x7B	130635810	80X507QBLT...	12 [305]	24 [610]	5.69 [145]	8.31 [211]	7.28 [185]	26.31 [668]	5 [127]	8.5 [216]	8 [203]	0.88 [22]	7.62 [194]	10.1 [257]	0.25
5x5x9.5B	130637570	80X509HGLT...	14.5 [368]	29 [737]	7.02 [178]	9.57 [243]	7.7 [196]	33.12 [841]	6 [152]	8.5 [216]	8 [203]	0.88 [22]	12.17 [309]	14.25 [362]	0.25
5x5x9.5B	130638390	80X509YFLT...	14.5 [368]	29 [737]	7.02 [178]	9.57 [243]	7.7 [196]	33.12 [841]	6 [152]	8.5 [216]	8 [203]	0.88 [22]	12.17 [309]	14.25 [362]	0.25
6x6x7B	130637450	80X607CFLT...	14 [356]	28 [711]	6.5 [165]	8.5 [216]	8.13 [207]	34.48 [876]	6 [152]	9.5 [241]	8 [203]	0.88 [22]	12.17 [309]	14.25 [362]	0.25
6x6x7B	130636730	80X607MELT...	14 [356]	28 [711]	6.5 [165]	8.5 [216]	8.13 [207]	30.18 [766]	6 [152]	9.5 [241]	8 [203]	0.88 [22]	9.48 [241]	11.89 [302]	0.25
6x6x7B	130636610	80X607SDLT...	14 [356]	28 [711]	6.5 [165]	8.5 [216]	8.13 [207]	30.18 [766]	6 [152]	9.5 [241]	8 [203]	0.88 [22]	9.48 [241]	11.89 [302]	0.25
6x6x9.5B	130637570	80X601FGLT...	16.75 [425]	33.5 [851]	7.57 [192]	10.67 [271]	8.88 [226]	34.42 [874]	6 [152]	9.5 [241]	8 [203]	0.88 [22]	12.17 [309]	14.25 [362]	0.25
6x6x9.5B	130638390	80X601WFLT...	16.75 [425]	33.5 [851]	7.57 [192]	10.67 [271]	8.88 [226]	34.42 [874]	6 [152]	9.5 [241]	8 [203]	0.88 [22]	12.17 [309]	14.25 [362]	0.25

## Series e-80X – Dimensions

(All dimensions in inches [mm]. Do not use for construction purposes.)

### Dimensions - Low speed (200-240V)

Pump Size	Motor Code	e-80X PN	A	B	C	D	G	Hv	V	125# ANSI			Rv	W	Gauge Tappings (NPT)
										J	N	P			
1.5x1.5x7C	130635811	80X157CBLS...	8 [203]	16 [406]	4.57 [116]	4.61 [117]	4.58 [116]	22.74 [578]	5 [127]	3.88 [99]	4 [102]	0.63 [16]	7.62 [194]	10.1 [257]	0.25
1.5x1.5x9.5B	130636611	80X159JDLS...	9.5 [241]	19 [483]	5.86 [149]	6.16 [156]	4.5 [114]	25.33 [643]	5 [127]	3.88 [99]	4 [102]	0.63 [16]	9.48 [241]	11.89 [302]	0.25
1.5x1.5x9.5B	130635811	80X159GBLS...	9.5 [241]	19 [483]	5.86 [149]	6.16 [156]	4.5 [114]	22.72 [577]	5 [127]	3.88 [99]	4 [102]	0.63 [16]	7.62 [194]	10.1 [257]	0.25
2x2x7B	130635811	80X207CBLS...	8.5 [216]	17 [432]	4.65 [118]	5.12 [130]	5.13 [130]	23.27 [591]	5 [127]	4.75 [121]	4 [102]	0.75 [19]	7.62 [194]	10.1 [257]	0.25
2x2x9.5C	130636731	80X209JELS...	10 [254]	20 [508]	6 [152]	6.5 [165]	5.38 [137]	26.27 [667]	5 [127]	4.75 [121]	4 [102]	0.75 [19]	9.48 [241]	11.89 [302]	0.25
2x2x9.5C	130635811	80X209EBLS...	10 [254]	20 [508]	6 [152]	6.5 [165]	5.38 [137]	23.70 [602]	5 [127]	4.75 [121]	4 [102]	0.75 [19]	7.62 [194]	10.1 [257]	0.25
2.5x2.5x7B	130635811	80X257CBLS...	9 [229]	18 [457]	4.7 [119]	5.46 [139]	5.4 [137]	23.81 [605]	5 [127]	5.5 [140]	4 [102]	0.75 [19]	7.62 [194]	10.1 [257]	0.25
2.5x2.5x9.5C	130636731	80X259JELS...	10.75 [273]	21.5 [546]	5.96 [151]	7.06 [179]	6 [152]	26.95 [685]	5 [127]	5.5 [140]	4 [102]	0.75 [19]	9.48 [241]	11.89 [302]	0.25
2.5x2.5x9.5C	130636611	80X259EDLS...	10.75 [273]	21.5 [546]	5.96 [151]	7.06 [179]	6 [152]	26.95 [685]	5 [127]	5.5 [140]	4 [102]	0.75 [19]	9.48 [241]	11.89 [302]	0.25
2.5x2.5x9.5C	130635811	80X259CBLS...	10.75 [273]	21.5 [546]	5.96 [151]	7.06 [179]	6 [152]	24.33 [618]	5 [127]	5.5 [140]	4 [102]	0.75 [19]	7.62 [194]	10.1 [257]	0.25
3x3x7C	130637731	80X307CCLS...	9.5 [241]	19 [483]	4.98 [126]	6.25 [159]	5.85 [149]	26.87 [682]	5 [127]	6 [152]	4 [102]	0.75 [19]	9.48 [241]	11.89 [302]	0.25
3x3x7C	130635811	80X307CBLS...	9.5 [241]	19 [483]	4.98 [126]	6.25 [159]	5.85 [149]	224.26 [616]	5 [127]	6 [152]	4 [102]	0.75 [19]	7.62 [194]	10.1 [257]	0.25

**Dimensions - Low speed (200-240V) (Continued)**

Pump Size	Motor Code	e-80X PN	A	B	C	D	G	Hv	V	125# ANSI			Rv	W	Gauge Tappings (NPT)
										J	N	P			
3x3x9.5C	130638391	80X309JFLS...	11.5 [292]	23 [584]	6.53 [166]	7.4 [188]	6.13 [156]	31.23 [793]	6 [152]	6 [152]	4 [102]	0.75 [19]	12.17 [309]	14.25 [362]	0.25
3x3x9.5C	130636731	80X309GELS...	11.5 [292]	23 [584]	6.53 [166]	7.4 [188]	6.13 [156]	26.93 [684]	5 [127]	6 [152]	4 [102]	0.75 [19]	9.48 [241]	11.89 [302]	0.25
3x3x9.5C	130636611	80X309YDLS...	11.5 [292]	23 [584]	6.53 [166]	7.4 [188]	6.13 [156]	26.93 [684]	5 [127]	6 [152]	4 [102]	0.75 [19]	9.48 [241]	11.89 [302]	0.25
3x3x11B	130637571	80X301LGLS...	12 [305]	24 [610]	6.99 [178]	7.13 [181]	6.75 [171]	30.71 [780]	6 [152]	6 [152]	4 [102]	0.75 [19]	12.17 [309]	14.25 [362]	0.25
3x3x11B	130638391	80X301KFLS...	12 [305]	24 [610]	6.99 [178]	7.13 [181]	6.75 [171]	30.71 [780]	6 [152]	6 [152]	4 [102]	0.75 [19]	12.17 [309]	14.25 [362]	0.25
3x3x11B	130636731	80X3019ELS...	12 [305]	24 [610]	6.99 [178]	7.13 [181]	6.75 [171]	27.40 [696]	6 [152]	6 [152]	4 [102]	0.75 [19]	9.48 [241]	11.89 [302]	0.25
4x4x7B	130636611	80X407CDLS...	10.5 [267]	21 [533]	5.28 [134]	6.53 [166]	6.57 [167]	27.84 [707]	5 [127]	7.5 [191]	8 [203]	0.75 [19]	9.48 [241]	11.89 [302]	0.25
4x4x7B	130635811	80X407ABLS...	10.5 [267]	21 [533]	5.28 [134]	6.53 [166]	6.57 [167]	25.2 [640]	5 [127]	7.5 [191]	8 [203]	0.75 [19]	7.62 [194]	10.1 [257]	0.25
4x4x9.5B	130637571	80X409JGLS...	12.5 [318]	25 [635]	6.51 [165]	7.94 [202]	7.25 [184]	32.67 [830]	6 [152]	7.5 [191]	8 [203]	0.75 [19]	12.17 [309]	14.25 [362]	0.25
4x4x9.5B	130638391	80X409GFLS...	12.5 [318]	25 [635]	6.51 [165]	7.94 [202]	7.25 [184]	32.67 [830]	6 [152]	7.5 [191]	8 [203]	0.75 [19]	12.17 [309]	14.25 [362]	0.25
4x4x9.5B	130636731	80X409YELS...	12.5 [318]	25 [635]	6.51 [165]	7.94 [202]	7.25 [184]	28.40 [720]	6 [152]	7.5 [191]	8 [203]	0.75 [19]	9.48 [241]	11.89 [302]	0.25
4x4x11	130637571	80X401KGLS...	13 [330]	26 [660]	7.01 [178]	8.22 [209]	7.5 [191]	31.65 [804]	6 [152]	7.5 [191]	8 [203]	0.75 [19]	12.17 [309]	14.25 [362]	0.25
4x4x11	130638391	80X401HFLS...	13 [330]	26 [660]	7.01 [178]	8.22 [209]	7.5 [191]	31.65 [804]	6 [152]	7.5 [191]	8 [203]	0.75 [19]	12.17 [309]	14.25 [362]	0.25
5x5x7B	130636731	80X507CELS...	12 [305]	24 [610]	5.69 [145]	8.31 [211]	7.28 [185]	28.92 [735]	5 [127]	8.5 [216]	8 [203]	0.88 [22]	9.48 [241]	11.89 [302]	0.25
5x5x7B	130636611	80X507ADLS...	12 [305]	24 [610]	5.69 [145]	8.31 [211]	7.28 [185]	28.92 [735]	5 [127]	8.5 [216]	8 [203]	0.88 [22]	9.48 [241]	11.89 [302]	0.25
5x5x7B	130635811	80X507QBLS...	12 [305]	24 [610]	5.69 [145]	8.31 [211]	7.28 [185]	26.31 [668]	5 [127]	8.5 [216]	8 [203]	0.88 [22]	7.62 [194]	10.1 [257]	0.25
5x5x9.5B	130637571	80X509HGLS...	14.5 [368]	29 [737]	7.02 [178]	9.57 [243]	7.7 [196]	33.12 [841]	6 [152]	8.5 [216]	8 [203]	0.88 [22]	12.17 [309]	14.25 [362]	0.25
5x5x9.5B	130638391	80X509YFLS...	14.5 [368]	29 [737]	7.02 [178]	9.57 [243]	7.7 [196]	33.12 [841]	6 [152]	8.5 [216]	8 [203]	0.88 [22]	12.17 [309]	14.25 [362]	0.25
6x6x7B	130637451	80X607CFLS...	14 [356]	28 [711]	6.5 [165]	8.5 [216]	8.13 [207]	34.48 [876]	6 [152]	9.5 [241]	8 [203]	0.88 [22]	12.17 [309]	14.25 [362]	0.25
6x6x7B	130636731	80X607MELS...	14 [356]	28 [711]	6.5 [165]	8.5 [216]	8.13 [207]	30.18 [766]	6 [152]	9.5 [241]	8 [203]	0.88 [22]	9.48 [241]	11.89 [302]	0.25
6x6x7B	130636611	80X607SDLS...	14 [356]	28 [711]	6.5 [165]	8.5 [216]	8.13 [207]	30.18 [766]	6 [152]	9.5 [241]	8 [203]	0.88 [22]	9.48 [241]	11.89 [302]	0.25
6x6x9.5B	130637571	80X601FGLS...	16.75 [425]	33.5 [851]	7.57 [192]	10.67 [271]	8.88 [226]	34.42 [874]	6 [152]	9.5 [241]	8 [203]	0.88 [22]	12.17 [309]	14.25 [362]	0.25
6x6x9.5B	130638391	80X601WFLS...	16.75 [425]	33.5 [851]	7.57 [192]	10.67 [271]	8.88 [226]	34.42 [874]	6 [152]	9.5 [241]	8 [203]	0.88 [22]	12.17 [309]	14.25 [362]	0.25



Learn more about  
e-80X Smart Pumps

**Xylem Product Cybersecurity:**

Xylem values your system security and the availability of your critical services. For more information on Xylem cybersecurity practices or to contact the cybersecurity team please visit [xylem.com/security](http://xylem.com/security).

**Xylem Inc.**  
8200 N. Austin Avenue  
Morton Grove, Illinois 60053

Phone: (847) 966-3700  
Fax: (847) 965-8379  
[www.xylem.com/bellgossett](http://www.xylem.com/bellgossett)

Subject to change without notice. All information presented herein is believed reliable and in accordance with accepted engineering practices. Xylem makes no warranties as to the completeness of this information. Users are responsible for evaluating individual product suitability for specific applications. Xylem assumes no liability whatsoever for any special, indirect or consequential damages arising from the sale, resale or misuse of its products.

© 2025 Xylem, Bell & Gossett and Hydrovar are registered trademarks of Xylem Inc. or one of its subsidiaries. MODBUS is a registered trademark of Schneider Electric USA, Inc. The Bluetooth word mark and logos are registered trademarks owned by Bluetooth SIG, Inc. and any use of such marks by Xylem Inc. or one of its subsidiaries is under license. All other trademarks or registered trademarks are the property of their respective owners.

