



# Series e-80SCX Smart Pumps

Integrated pump, motor & variable speed drive solutions,  
powered by hydrovar<sup>®</sup> X

Featuring sensorless technology

# Contents

General introduction .....	3
Applications and benefits .....	4
Performance coverage at 60 Hz, 2-poles and 4-poles .....	5
Assembly configurations .....	6
Specifications document list .....	9
Electrical data .....	10
Terminal block .....	15
How to read smart pump series curves .....	16
Sensorless selection strategy and limitations .....	17
Performance curves for high speed models - 460V .....	22
Performance curves for high speed models - 230V .....	39
Performance curves for low speed models .....	48
Materials of construction .....	72
Seal assemblies .....	72
Dimensions and weights .....	73

## General introduction

Powered by Xylem's hydrovar® X Smart Motor, Series e-80SCX Smart Pumps offer customizable pumping solutions designed to deliver ultra-premium efficiency, connectivity, and simplicity right out of the box!

Series e-80SCX Smart Pumps integrate decades of expertise and know-how in pumping solutions to bring the right combination of Motors, variable speed drives and hydraulic pumps in one comprehensive, highly efficient package. Series e-80SCX Smart Pumps reduce electricity consumption, improve overall system performance, and lower life cycle costs. The extensive energy saving profile enables users to maintain significantly higher levels of efficiency over a much wider range of operating conditions. Designed for horizontal and vertical in-line mounting, it's ideal for hydronic heating and cooling systems, light industrial processes and general service.

So, when it's time to think efficiency, performance and reliable market-leading technology ... start with Series e-80SCX Smart Pumps from Bell & Gossett – a complete system, delivering the solutions you need for today.

### Hydraulic specifications

- **Maximum flow:** up to **1400 GPM**
- **Maximum head:** up to **428 ft TDH<sup>1</sup>**
- Hydraulic performance compliant with **ANSI/HI 14.6 Grade 2B**
- **Maximum temperature:** up to 250 °F (121 °C)
- **Maximum working pressure:** 175 psi (12 bar)<sup>2</sup>

1 The 1.5x9.5B model may exceed the nominal 175 psi rating when operating above 3600 RPM in low-flow conditions. For reliable operation, observe the recommended maximum speed limits indicated on the individual performance curves and adjust the Motor speed to avoid exceeding the 175 psi maximum working pressure.

2 See mechanical seal options for temperature limitations.

### Motor specifications

hydrovar X:

- IES2 power drive system (PDS) efficiency (IEC 61800-9-2:2017)
- IE5 motor efficiency (IEC TS 60034-30-2:2016)
- NEMA 4
- Insulation class 115 (Class F)
- Totally enclosed fan cooled (TEFC) construction
- 3-phase power supply
- **Rated speeds (high speed models):**  
3000 - 4000 RPM<sup>3</sup>
- **Rated speeds (low speed models):**  
1500 - 2000 RPM<sup>3</sup>
- **High speed models:** 3 kW to 22 kW (4 HP to 30 HP):  
200-240V and 380-480V +/- 10%, 50/60Hz
- **Low speed models:** 1.5 kW to 11 kW (2 HP to 15 HP):  
200-240V and 380-480V +/- 10%, 50/60Hz
- RS485 communication interface, BACnet and Modbus standard and BLE included
- Overload and locked rotor protection with automatic reset included
- Multi-pump linking (up to 8 pumps)

3 Rated speeds are used to determine the net efficiency of a pump-drive system and for energy efficiency listings. Pumps may or may not utilize the full speed range of hydrovar X depending on a variety of factors or limitations. Models may operate below rated speed at partial loading. See individual performance curves for more detail.

## Applications

The **Series e-80SCX** is suitable for the following applications:

- Chilled water
- Commercial HVAC
- Hydronic heating and cooling systems
- Cooling towers and industrial uses
- Pressure boosting
- General liquid transfer

### **Pumped fluids:**

- Unheated domestic and fresh water
- Boiler feed water
- Condensate
- Benign liquids

## Benefits

The **Series e-80SCX** provides the following benefits:

**Ease of installation and maintenance:** the integrated pump and hydrovar X Smart Motor package eliminates additional wiring, labor, and costs associated with a traditional variable frequency drive (VFD) package. The hydrovar X motor features a quick-connect electrical socket between the Motor and drive for rapid maintenance.

**Intelligent performance:** advanced control systems embedded within the hydrovar X motor are customizable for a wide range of applications and multi-pump support (up to 8 pumps) for parallel pumping installations.

**Simple:** the hydrovar X Smart Motor is easy to configure and commission. Follow the start-up genie to quickly tailor the Motor to its intended application. Control selections and navigate menus via a full color graphical display.

**Built-in protections:** integrated functions protect the pump and motor when operating near the current and power limits of the system.

**High efficiency:** the IE5 “ultra-premium” hydrovar X motor provides one of the broadest efficiency ranges in the industry.

# Performance coverage at 60HZ (Supply frequency)

e-80SCX high speed hydraulic performance

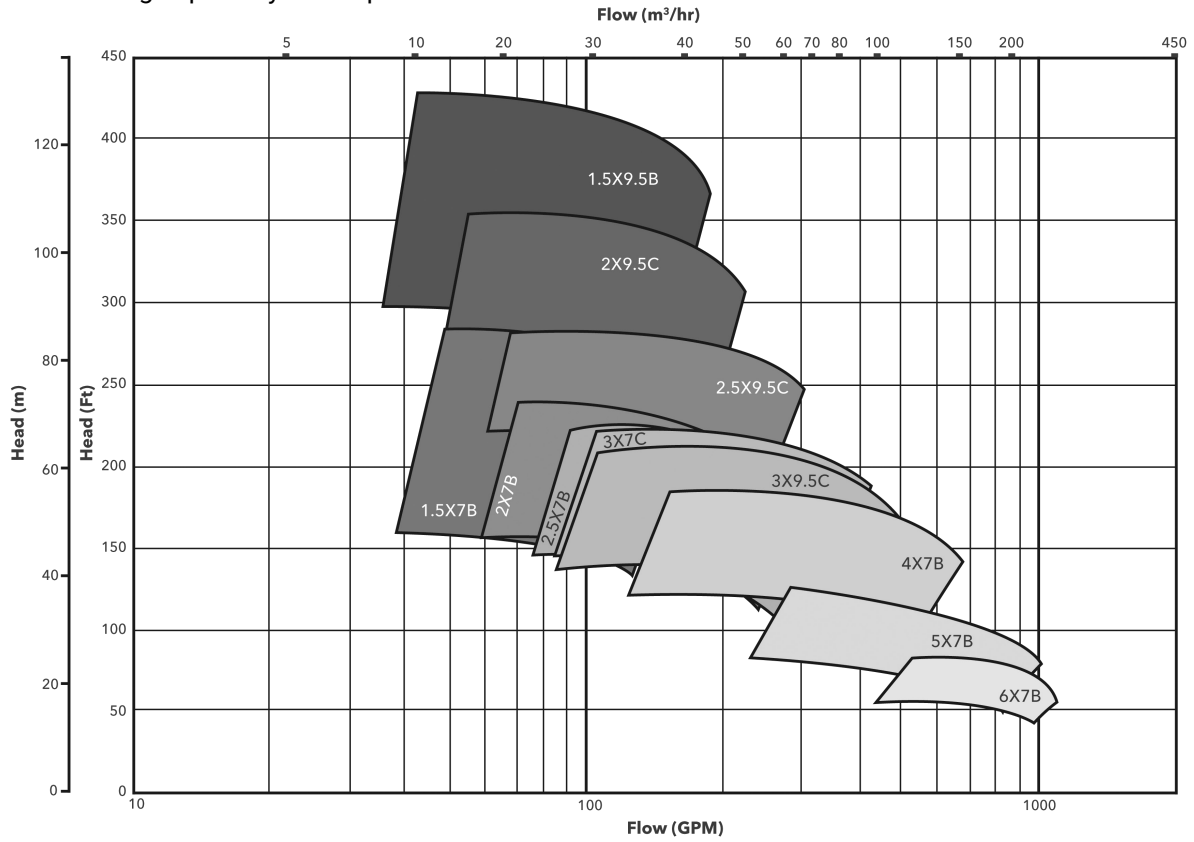

e-80SCX low speed hydraulic performance

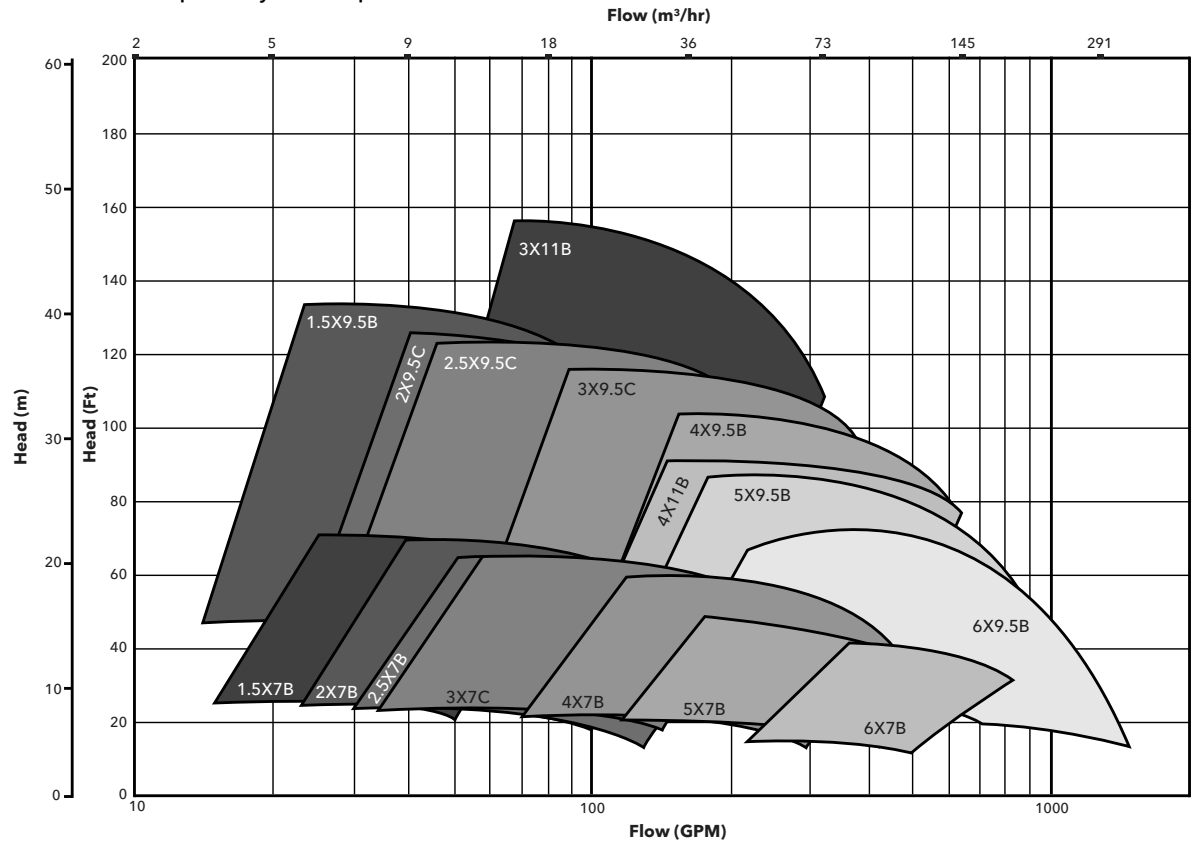

## Series e-80SCX Assembly configurations

High speed (800-4000 RPM) 3-phase - 380-480V (460V nominal voltage)

Pump size	Impeller trim (in.)	Motor HP	Motor code	NEMA frame	EPR/C/SiC	EPR/SiC/SiC	Motor type
1.5x1.5x7C	7	15	130636330	213TC	80SCX157CGMTXW	80SCX157CGMTXZ	EXM213-215/4.150CH2
1.5x1.5x7C	6	7.5	130635370	143TC	80SCX157AEMTXW	80SCX157AEMTXZ	EXM143-145/4.075BH2
1.5x1.5x9.5B	9.5	30	130637170	254TC	80SCX159JNMTXW	80SCX159JNMTXZ	EXM254-256/4.300DH2
1.5x1.5x9.5B	8.5	20	130636930	254TC	80SCX159GHMTXW	80SCX159GHMTXZ	EXM254-256/4.200DH2
2x2x7B	7	20	130636930	254TC	80SCX207CHMTXW	80SCX207CHMTXZ	EXM254-256/4.200DH2
2x2x7B	6	10	130636210	213TC	80SCX207AFMTXW	80SCX207AFMTXZ	EXM213-215/4.100CH2
2x2x9.5C	8.5	30	130637170	254TC	80SCX209GNMTXW	80SCX209GNMTXZ	EXM254-256/4.300DH2
2.5x2.5x7B	7	20	130636930	254TC	80SCX257CHMTXW	80SCX257CHMTXZ	EXM254-256/4.200DH2
2.5x2.5x7B	6	10	130636210	213TC	80SCX257AFMTXW	80SCX257AFMTXZ	EXM213-215/4.100CH2
2.5x2.5x9.5C	8	30	130637170	254TC	80SCX259ENMTXW	80SCX259ENMTXZ	EXM254-256/4.300DH2
3x3x7C	7	30	130637170	254TC	80SCX307CNMTXW	80SCX307CNMTXZ	EXM254-256/4.300DH2
3x3x7C	5.5	15	130636330	213TC	80SCX307QGMTXW	80SCX307QGMTXZ	EXM213-215/4.150CH2
3x3x9.5C	7.25	30	130637170	254TC	80SCX309DNMTXW	80SCX309DNMTXZ	EXM254-256/4.300DH2
4x4x7B	6.5	30	130637170	254TC	80SCX407BNMTXW	80SCX407BNMTXZ	EXM254-256/4.300DH2
4x4x7B	6	25	130637050	254TC	80SCX407AJMTXW	80SCX407AJMTXZ	EXM254-256/4.250DH2
5x5x7B	5.5	30	130637170	254TC	80SCX507QNMTXW	80SCX507QNMTXZ	EXM254-256/4.300DH2
6x6x7B	5.5	30	130637170	254TC	80SCX607QNMTXW	80SCX607QNMTXZ	EXM254-256/4.300DH2

High speed (800-4000 RPM) 3-phase - 200-240V (230V nominal voltage)

Pump size	Impeller trim (in.)	Motor HP	Motor code	NEMA frame	EPR/C/SiC	EPR/SiC/SiC	Motor type
1.5x1.5x7C	6	7.5	130636091	213TC	80SCX157AEMSXW	80SCX157AEMSXZ	EXM213-215/3.075CH2
1.5x1.5x9.5B	8.5	20	130636931	254TC	80SCX159GHMSXW	80SCX159GHMSXZ	EXM254-256/3.200DH2
2x2x7B	7	20	130636931	254TC	80SCX207CHMSXW	80SCX207CHMSXZ	EXM254-256/3.200DH2
2x2x9.5C	7.25	20	130636931	254TC	80SCX209DHMSXW	80SCX209DHMSXZ	EXM254-256/3.200DH2
2.5x2.5x7B	7	20	130636931	254TC	80SCX257CHMSXW	80SCX257CHMSXZ	EXM254-256/3.200DH2
3x3x7C	6.5	20	130636931	254TC	80SCX307BHMSXW	80SCX307BHMSXZ	EXM254-256/3.200DH2
3x3x7C	5.5	15	130636811	254TC	80SCX307QGMSXW	80SCX307QGMSXZ	EXM213-215/3.150DH2
4x4x7B	5.75	20	130636931	254TC	80SCX407RHMSXW	80SCX407RHMSXZ	EXM254-256/3.200DH2
5x5x7B	5	20	130636931	254TC	80SCX507PHMSXW	80SCX507PHMSXZ	EXM254-256/3.200DH2

## Series e-80SCX

### Assembly configurations

Low speed (400-2000 RPM) 3-phase - 380-480V (460V nominal voltage)

Pump size	Impeller trim (in.)	Motor HP	Motor code	NEMA frame	EPR/C/SiC	EPR/SiC/SiC	Motor type
1.5x1.5x7C	7	3	130635770	143TC	80SCX157CBLTXW	80SCX157CBLTXZ	EXM143-145/4.030BH4
1.5x1.5x9.5B	9.5	5.5	130636570	213TC	80SCX159JDLTXW	80SCX159JDLTXZ	EXM213-215/4.055CH4
1.5x1.5x9.5B	8.5	3	130635770	143TC	80SCX159GBLTXW	80SCX159GBLTXZ	EXM143-145/4.030BH4
2x2x7B	7	3	130635770	143TC	80SCX207CBLTXW	80SCX207CBLTXZ	EXM143-145/4.030BH4
2x2x9.5C	9.5	7.5	130636690	213TC	80SCX209JELTXW	80SCX209JELTXZ	EXM213-215/4.075CH4
2x2x9.5C	8	3	130635770	143TC	80SCX209EBLTXW	80SCX209EBLTXZ	EXM143-145/4.030BH4
2.5x2.5x7B	7	3	130635770	143TC	80SCX257CBLTXW	80SCX257CBLTXZ	EXM143-145/4.030BH4
2.5x2.5x9.5C	9.5	7.5	130636690	213TC	80SCX259JELTXW	80SCX259JELTXZ	EXM213-215/4.075CH4
2.5x2.5x9.5C	8	5.5	130636570	213TC	80SCX259EDLTXW	80SCX259EDLTXZ	EXM213-215/4.055CH4
3x3x7C	7	4	130636450	213TC	80SCX307CCLTXW	80SCX307CCLTXZ	EXM213-215/4.040CH4
3x3x9.5C	9.5	10	130637410	254TC	80SCX309JFLTXW	80SCX309JFLTXZ	EXM254-256/4.100DH4
3x3x9.5C	8.5	7.5	130636690	213TC	80SCX309GELTXW	80SCX309GELTXZ	EXM213-215/4.075CH4
3x3x11B	11	15	130637530	254TC	80SCX301LGLTXW	80SCX301LGLTXZ	EXM254-256/4.150DH4
3x3x11B	10.5	10	130637410	254TC	80SCX301KFLTXW	80SCX301KFLTXZ	EXM254-256/4.100DH4
4x4x7B	7	5.5	130636570	213TC	80SCX407CDLTXW	80SCX407CDLTXZ	EXM213-215/4.055CH4
4x4x9.5B	9.5	15	130637530	254TC	80SCX409JGLTXW	80SCX409JGLTXZ	EXM254-256/4.150DH4
4x4x9.5B	8.5	10	130637410	254TC	80SCX409GFLTXW	80SCX409GFLTXZ	EXM254-256/4.100DH4
4x4x11	10.5	15	130637530	254TC	80SCX401KGLTXW	80SCX401KGLTXZ	EXM254-256/4.150DH4
5x5x7B	7	7.5	130636690	213TC	80SCX507CELTXW	80SCX507CELTXZ	EXM213-215/4.075CH4
5x5x7B	6	5.5	130636570	213TC	80SCX507ADLTXW	80SCX507ADLTXZ	EXM213-215/4.055CH4
5x5x9.5B	9	15	130637530	254TC	80SCX509HGLTXW	80SCX509HGLTXZ	EXM254-256/4.150DH4
6x6x7B	7	10	130637410	254TC	80SCX607CFLTXW	80SCX607CFLTXZ	EXM254-256/4.100DH4
6x6x7B	7.5	6.75	130636690	213TC	80SCX607MELTXW	80SCX607MELTXZ	EXM213-215/4.075CH4
6x6x9.5B	8.25	15	130637530	254TC	80SCX609FGLTXW	80SCX609FGLTXZ	EXM254-256/4.150DH4

## Series e-80SCX

### Assembly configurations

Low speed (400-2000 RPM) 3-phase - 200-240V (230V nominal voltage)

Pump size	Impeller trim (in.)	Motor HP	Motor code	NEMA frame	EPR/C/SiC	EPR/SiC/SiC	Motor type
1.5x1.5x7C	7	3	130635771	143TC	80SCX157CBLSXW	80SCX157CBLSXZ	EXM143-145/3.030BH4
1.5x1.5x9.5B	9.5	5.5	130636571	213TC	80SCX159JDLSXW	80SCX159JDLSXZ	EXM213-215/3.055CH4
1.5x1.5x9.5B	8.5	3	130635771	143TC	80SCX159GBLSXW	80SCX159GBLSXZ	EXM143-145/3.030BH4
2x2x7B	7	3	130635771	143TC	80SCX207CBLSXW	80SCX207CBLSXZ	EXM143-145/3.030BH4
2x2x9.5C	9.5	7.5	130636691	213TC	80SCX209JELSXW	80SCX209JELSXZ	EXM213-215/3.075CH4
2x2x9.5C	8	3	130635771	143TC	80SCX209EBSXW	80SCX209EBSXZ	EXM143-145/3.030BH4
2.5x2.5x7B	7	3	130635771	143TC	80SCX257CBLSXW	80SCX257CBLSXZ	EXM143-145/3.030BH4
2.5x2.5x9.5C	9.5	7.5	130636691	213TC	80SCX259JELSXW	80SCX259JELSXZ	EXM213-215/3.075CH4
2.5x2.5x9.5C	8	5.5	130636571	213TC	80SCX259EDLSXW	80SCX259EDLSXZ	EXM213-215/3.055CH4
3x3x7C	7	4	130636451	213TC	80SCX307CCLSXW	80SCX307CCLSXZ	EXM213-215/3.040CH4
3x3x9.5C	9.5	10	130637411	254TC	80SCX309JFLSXW	80SCX309JFLSXZ	EXM254-256/3.100DH4
3x3x9.5C	8.5	7.5	130636691	213TC	80SCX309GELSXW	80SCX309GELSXZ	EXM213-215/3.075CH4
3x3x11B	11	15	130637531	254TC	80SCX301LGLSXW	80SCX301LGLSXZ	EXM254-256/3.150DH4
3x3x11B	10.5	10	130637411	254TC	80SCX301KFLSXW	80SCX301KFLSXZ	EXM254-256/3.100DH4
4x4x7B	7	5.5	130636571	213TC	80SCX407CDLSXW	80SCX407CDLSXZ	EXM213-215/3.055CH4
4x4x9.5B	9.5	15	130637531	254TC	80SCX409JGLSXW	80SCX409JGLSXZ	EXM254-256/3.150DH4
4x4x9.5B	8.5	10	130637411	254TC	80SCX409GFLSXW	80SCX409GFLSXZ	EXM254-256/3.100DH4
4x4x11	10.5	15	130637531	254TC	80SCX401KGLSXW	80SCX401KGLSXZ	EXM254-256/3.150DH4
5x5x7B	7	7.5	130636691	213TC	80SCX507CELSXW	80SCX507CELSXZ	EXM213-215/3.075CH4
5x5x7B	6	5.5	130636571	213TC	80SCX507ADLSXW	80SCX507ADLSXZ	EXM213-215/3.055CH4
5x5x9.5B	9	15	130637531	254TC	80SCX509HGLSXW	80SCX509HGLSXZ	EXM254-256/3.150DH4
6x6x7B	7	10	130637411	254TC	80SCX607CFLSXW	80SCX607CFLSXZ	EXM254-256/3.100DH4
6x6x7B	7.5	6.75	130636691	213TC	80SCX607MELSXW	80SCX607MELSXZ	EXM213-215/4.075CH4
6x6x9.5B	8.25	15	130637531	254TC	80SCX609FGLSXW	80SCX609FGLSXZ	EXM254-256/3.150DH4

## Series e-80SCX motor specifications document list<sup>1</sup>

Speed tier	Motor type	Voltage range	Power (hp)	Motor frame	Specification document number
High speed	EXM56/4.040BH2	380-480V	4	56	XY-hyXeXM-SUB-520
	EXM143-145/4.040BH2		4	143-145	XY-hyXeXM-SUB-521
	EXM143-145/4.055BH2		5.5	143-145	XY-hyXeXM-SUB-522
	EXM143-145/4.075BH2		7.5	143-145	XY-hyXeXM-SUB-523
	EXM213-215/4.075CH2		7.5	213-215	XY-hyXeXM-SUB-524
	EXM213-215/4.100CH2		10	213-215	XY-hyXeXM-SUB-525
	EXM213-215/4.150CH2		15	213-215	XY-hyXeXM-SUB-526
	EXM254-256/4.150DH2		15	254-256	XY-hyXeXM-SUB-527
	EXM254-256/4.200DH2		20	254-256	XY-hyXeXM-SUB-528
	EXM254-256/4.250DH2		25	254-256	XY-hyXeXM-SUB-529
	EXM254-256/4.300DH2		30	254-256	XY-hyXeXM-SUB-530
	EXM56/3.040BH2		200-240V	4	56
	EXM143-145/3.040BH2	4		143-145	XY-hyXeXM-SUB-536
	EXM213-215/3.075CH2	7.5		213-215	XY-hyXeXM-SUB-537
	EXM254-256/3.150DH2	15		254-256	XY-hyXeXM-SUB-538
	EXM254-256/3.200DH2	20		254-256	XY-hyXeXM-SUB-539
Low speed	EXM56/4.020BH4	380-480V	2	56	XY-hyXeXM-SUB-542
	EXM56/4.030BH4		3	56	XY-hyXeXM-SUB-543
	EXM143-145/4.020BH4		2	143-145	XY-hyXeXM-SUB-544
	EXM143-145/4.030BH4		3	143-145	XY-hyXeXM-SUB-545
	EXM213-215/4.040CH4		4	213-215	XY-hyXeXM-SUB-546
	EXM213-215/4.055CH4		5.5	213-215	XY-hyXeXM-SUB-547
	EXM213-215/4.075CH4		7.5	213-215	XY-hyXeXM-SUB-548
	EXM254-256/4.075DH4		7.5	254-256	XY-hyXeXM-SUB-549
	EXM254-256/4.100DH4		10	254-256	XY-hyXeXM-SUB-550
	EXM254-256/4.150DH4		15	254-256	XY-hyXeXM-SUB-551
	EXM56/3.020BH4	200-240V	2	56	XY-hyXeXM-SUB-552
	EXM56/3.030BH4		3	56	XY-hyXeXM-SUB-553
	EXM143-145/3.020BH4		2	143-145	XY-hyXeXM-SUB-554
	EXM143-145/3.030BH4		3	143-145	XY-hyXeXM-SUB-555
	EXM213-215/3.040CH4		4	213-215	XY-hyXeXM-SUB-556
	EXM213-215/3.055CH4		5.5	213-215	XY-hyXeXM-SUB-557
	EXM213-215/3.075CH4		7.5	213-215	XY-hyXeXM-SUB-558
	EXM254-256/3.075DH4		7.5	254-256	XY-hyXeXM-SUB-559
	EXM254-256/3.100DH4		10	254-256	XY-hyXeXM-SUB-560
	EXM254-256/3.150DH4		15	254-256	XY-hyXeXM-SUB-561

<sup>1</sup> The table above consists of all NEMA frame hydrovar X Motor types. Not all Motor types are used in the e-80SCX product line.

## Series e-80SCX electrical data

\* Please note: efficiency values shown are power-drive-system (PDS) efficiencies which include the combined losses from both the inverter and Motor. The values shown correspond to the full load range of the hydrovar X Motor. The hydrovar X Motor may operate below the minimum rated speed at partial loading.

Table 1: 56 frame, high speed, 380-480V

Pn HP	Motor type	NEMA frame	Speed (RPM) min-1	Input current (I) 380-480V A	Data related to 460V						
					In	Power factor cos (φ)	Tn lb.ft	*PDS efficiency η%			
					A			100	75	50	
4.0	EXM56/4.040BH2	56	3000	6.7-5.3	5.4	0.80	7.04	87.6	87.5	86.0	
			3600		5.3			5.87	88.0	87.4	85.4
			4000		5.3			5.28	88.1	87.1	84.9

Table 2: 56 frame, high speed, 200-240V

Pn HP	Motor type	NEMA frame	Speed (RPM) min-1	Input current (I) 200-240V A	Data related to 230V						
					In	Power factor cos (φ)	Tn lb.ft	*PDS efficiency η%			
					A			100	75	50	
4.0	EXM56/3.040BH2	56	-	10.7-8.9	-	0.94	-	-	-	-	
			3600		9.2			5.87	87.2	87.1	85.9
			4000		9.1			5.28	88.0	87.8	86.4

Table 3: 143-145 frame high speed, 380-480V

Pn HP	Motor type	NEMA frame	Speed (RPM) min-1	Input current (I) 380-480V A	Data related to 460V						
					In	Power factor cos (φ)	Tn lb.ft	*PDS efficiency η%			
					A			100	75	50	
4.0	EXM143-145/4.040BH2	143-145	3000	6.7-5.3	5.4	0.80	7.04	87.6	87.5	86.0	
			3600		5.3			5.87	88.0	87.4	85.4
			4000		5.3			5.28	88.1	87.1	84.9
5.5	EXM143-145/4.055BH2		3000	7.7-6.6	6.8	0.86	9.39	87.3	87.7	87.5	
			3600		6.6			7.83	89.1	88.8	87.3
			4000		6.5			7.04	89.1	88.5	86.8
7.5	EXM143-145/4.075BH2		3000	10.2-8.4	8.6	0.89	12.91	89.9	89.9	89.2	
			3600		8.6			10.76	89.7	89.5	88.5
			4000		8.4			9.68	90.5	89.4	87.4

## Series e-80SCX electrical data

Table 4: 143-145 frame high speed, 200-240V

Pn HP	Motor type	NEMA frame	Speed (RPM) min-1	Input current (I) 200-240V A	Data related to 230V						
					In A	Power factor cos (φ)	Tn lb.ft	*PDS efficiency η%			
								100	75	50	
4.0	EXM143-145/3.040BH2	143-145	3000	10.7-8.9	-	0.94	-	-	-	-	
			3600		9.2		5.87	87.2	87.1	85.9	
			4000		9.1		5.28	88.0	87.8	86.4	
5.5	EXM143-145/3.055BH2		3000	Unavailable							
			3600								
			4000								
7.5	EXM143-145/3.075BH2		3000	Unavailable							
			3600								
			4000								

Table 5: 213-215 frame, high speed, 380-480V

Pn HP	Motor type	NEMA frame	Speed (RPM) min-1	Input current (I) 380-480V A	Data related to 460V					
					In A	Power factor cos (φ)	Tn lb.ft	*PDS efficiency η%		
								100	75	50
7.50	EXM213-215/4.075CH2	213-215	3000	11.4-11.0	11.1	0.72	12.92	90.5	90.1	88.8
			3600		10.6		10.76	90.8	90.1	88.5
			4000		10.6		9.68	90.5	89.5	87.4
10.0	EXM213-215/4.100CH2		3000	14.4-12.5	12.2	0.85	17.61	90.8	90.1	88.4
			3600		12.4		14.67	90.2	89.2	87.0
			4000		12.0		13.20	90.6	89.5	87.1
15.0	EXM213-215/4.150CH2		3000	20.3-16.5	16.8	0.90	25.82	91.2	90.7	89.3
			3600		16.9		21.52	91.1	90.5	89.1
			4000		17.0		19.37	90.6	90.2	88.4

Table 6: 213-215 frame, high speed, 200-240V

Pn HP	Motor type	NEMA frame	Speed (RPM) min-1	Input current (I) 200-240V A	Data related to 230V						
					In A	Power factor cos (φ)	Tn lb.ft	*PDS efficiency η%			
								100	75	50	
7.50	EXM213-215/3.075CH2	213-215	3000	18.9-16.2	16.7	0.94	12.92	89.6	89.3	88.2	
			3600		16.3		10.76	89.9	89.2	87.6	
			4000		16.6		9.68	88.6	87.6	85.1	
10.0	EXM213-215/3.100CH2		3000	Unavailable							
			3600								
			4000								
15.0	EXM213-215/3.150CH2		3000	Unavailable							
			3600								
			4000								

\* Please note: efficiency values shown are power-drive-system (PDS) efficiencies which include the combined losses from both the inverter and Motor. The values shown correspond to the full load range of the hydrovar X Motor. The hydrovar X Motor may operate below the minimum rated speed at partial loading.

## Series e-80SCX electrical data

Table 7: 254-256 frame, high speed, 380-480V

Pn HP	Motor type	NEMA frame	Speed (RPM) min-1	Input current (I) 380-480V A	Data related to 460V					
					In A	Power factor cos (φ)	Tn lb.ft	*PDS efficiency η%		
								100	75	50
15.00	EXM254-256/4.150DH2	254-256	3000	24.5-22.8	21.7	0.72	25.82	91.7	91.2	90.2
			3600		20.9		21.52	92.0	91.2	89.9
			4000		20.5		19.37	91.5	90.6	88.8
20.0	EXM254-256/4.200DH2		3000	30.2-27.1	24.5	0.76	35.22	91.5	91.2	90.1
			3600		27.0		29.35	92.1	91.4	90.1
			4000		26.8		26.41	91.8	91.1	89.6
25.0	EXM254-256/4.250DH2		3000	33.5-28.6	29.4	0.87	43.44	91.7	91.4	90.7
			3600		28.9		36.19	92.1	91.5	90.4
			4000		28.8		32.58	92.0	91.4	90.2
30.0	EXM254-256/4.300DH2		3000	38.9-32.4	33.5	0.90	51.65	92.1	91.7	90.7
			3600		33.3		43.04	92.5	91.8	90.6
			4000		32.7		38.83	92.4	91.6	90.2

Table 8: 254-256 frame, high speed, 200-240V

Pn HP	Motor type	NEMA frame	Speed (RPM) min-1	Input current (I) 200-240V A	Data related to 230V						
					In A	Power factor cos (φ)	Tn lb.ft	*PDS efficiency η%			
								100	75	50	
15.00	EXM254-256/3.150DH2	254-256	3000	38.4-34.1	35.4	0.90	25.82	90.3	90.3	89.4	
			3600		33.7		21.52	91.2	90.8	89.7	
			4000		32.5		19.37	91.3	90.6	89.3	
20.0	EXM254-256/3.200DH2		-	50.0-44.1	-	0.92	-	-	-	-	
			3600		44.9		29.35	91.1	90.6	89.5	
			4000		44.4		26.41	90.3	89.4	87.5	
25.0	EXM254-256/3.250DH2		3000		Unavailable						
			3600		Unavailable						
			4000		Unavailable						
30.0	EXM254-256/3.300DH2		3000		Unavailable						
			3600		Unavailable						
			4000		Unavailable						

Table 9: 56 frame, low speed, 380-480V

Pn HP	Motor type	NEMA frame	Speed (RPM) min-1	Input current (I) 380-480V A	Data related to 460V					
					In A	Power factor cos (φ)	Tn lb.ft	*PDS efficiency η%		
								100	75	50
2.0	EXM56/4.020BH4	56	1500	4.0-3.8	3.70	0.57	7.04	82.2	83.2	83.0
			1800		3.90		5.87	85.1	85.9	85.6
			2000		3.50		5.28	86.7	86.4	85.3
3.0	EXM56/4.030BH4		1500	5.0-4.6	4.70	0.69	10.33	85.6	85.8	84.9
			1800		4.60		8.61	88.0	87.6	86.5
			2000		4.50		7.74	89.0	88.6	87.3

\* Please note: efficiency values shown are power-drive-system (PDS) efficiencies which include the combined losses from both the inverter and Motor. The values shown correspond to the full load range of the hydrovar X Motor. The hydrovar X Motor may operate below the minimum rated speed at partial loading.

## Series e-80SCX electrical data

Table 10: 143-145 frame low speed, 200-240V

Pn HP	Motor type	NEMA frame	Speed (RPM) min-1	Input current (I) 200-240V A	Data related to 230V					
					In A	Power factor cos (φ)	Tn lb.ft	*PDS efficiency η%		
								100	75	50
2.0	EXM56/3.020BH4	56	1500	5.7-4.9	5.1	0.89	7.04	83.2	83.8	83.5
			1800		4.9		5.87	85.7	85.9	85.3
			2000		4.9		5.28	86.5	85.7	83.6
3.0	EXM56/3.030BH4		1500	7.9-6.7	7.00	0.93	10.33	86.0	86.3	86.2
			1800		6.80		8.63	87.9	87.7	86.8
			2000		6.70		7.74	88.9	88.9	87.9

Table 11: 143-145 frame low speed, 380-480V

Pn HP	Motor type	NEMA frame	Speed (RPM) min-1	Input current (I) 380-480V A	Data related to 460V					
					In A	Power factor cos (φ)	Tn lb.ft	*PDS efficiency η%		
								100	75	50
2.0	EXM143- 145/4.020BH4	143-145	1500	4.0-3.8	3.70	0.57	7.04	82.2	83.2	83.0
			1800		3.90		5.87	85.1	85.9	85.6
			2000		3.50		5.28	86.7	86.4	85.3
3.0	EXM143- 145/4.030BH4		1500	5.0-4.6	4.70	0.69	10.33	85.6	85.8	84.9
			1800		4.60		8.61	88.0	87.6	86.5
			2000		4.50		7.74	89.0	88.6	87.3

Table 12: 143-145 frame, low speed, 200-240V

Pn HP	Motor type	NEMA frame	Speed (RPM) min-1	Input current (I) 200-240V A	Data related to 230V					
					In A	Power factor cos (φ)	Tn lb.ft	*PDS efficiency η%		
								100	75	50
2.0	EXM143- 145/3.020BH4	143-145	1500	5.7-4.9	5.1	0.89	7.04	83.2	83.8	83.5
			1800		4.9		5.87	85.7	85.9	85.3
			2000		4.9		5.28	86.5	85.7	83.6
3.0	EXM143- 145/3.030BH4		1500	7.9-6.7	7.00	0.93	10.33	86.0	86.3	86.2
			1800		6.80		8.63	87.9	87.7	86.8
			2000		6.70		7.74	88.9	88.9	87.9

Table 13: HX-C-LS-HV

Pn HP	Motor type	NEMA frame	Speed (RPM) min-1	Input current (I) 380-480V A	Data related to 460V					
					In A	Power factor cos (φ)	Tn lb.ft	*PDS efficiency η%		
								100	75	50
4.0	EXM213- 215/4.040CH4	213-215	1500	7.9-7	7.2	0.62	14.09	86.3	86.6	85.7
			1800		6.9		11.73	88.1	87.9	86.8
			2000		7		10.55	88.5	88.2	87.1
5.5	EXM213- 215/4.055CH4		1500	9.2-8.5	8.9	0.66	18.78	89.4	89.4	88.8
			1800		8.4		15.65	91.2	91.1	90.4
			2000		8.3		14.09	91.6	91.5	90.8
7.5	EXM213- 215/4.075CH4		1500	11.2-10.2	10.3	0.75	25.82	90.7	90.8	90.4
			1800		10.1		21.52	91.6	91.8	90.6
			2000		10.1		19.37	91.6	91.3	90.5

\* Please note: efficiency values shown are power-drive-system (PDS) efficiencies which include the combined losses from both the inverter and Motor. The values shown correspond to the full load range of the hydrovar X Motor. The hydrovar X Motor may operate below the minimum rated speed at partial loading.

## Series e-80SCX electrical data

Table 14: 213-215 frame low speed, 200-240V

Pn HP	motor type	NEMA frame	Speed (RPM) min-1	Input current (I) 200-240V A	Data related to 230V					
					In A	Power factor cos (φ)	Tn lb.ft	*PDS efficiency η%		
								100	75	50
4.00	EXM213- 215/3.040CH4	213-215	1500	11.0-9.8	9.9	0.87	14.09	87.2	87.4	87.1
			1800		9.8		11.73	88.3	88.3	87.7
			2000		9.8		10.55	88.4	88.7	87.7
5.5	EXM213- 215/3.055CH4		1500	14.0-12.3	12.5	0.92	18.81	88.4	88.8	88.7
			1800		12.2		15.64	89.9	89.8	89.3
			2000		12.1		14.09	90.2	90.4	89.6
7.5	EXM213- 215/3.075CH4		1500	21.6-20.4	16.6	0.93	25.82	89.4	89.7	89.5
			1800		16.5		21.52	90.2	90.5	90.2
			2000		16.6		19.37	90.1	90.4	90.1

Table 15: 254-256 frame, low speed, 380-480V

Pn HP	Motor type	NEMA frame	Speed (RPM) min-1	Input current (I) 380-480V A	Data related to 460V					
					In A	Power factor cos (φ)	Tn lb.ft	*PDS efficiency η%		
								100	75	50
7.50	EXM254- 256/4.075DH4	254-256	1500	15.3-13.6	14.1	0.55	25.82	88.6	88.6	87.9
			1800		13.8		21.52	90.9	90.7	89.8
			2000		14.3		19.37	91.0	91.1	90.4
10.0	EXM254- 256/4.100DH4		1500	18.7-17.4	17.8	0.60	35.22	89.6	89.9	89.7
			1800		17.3		29.35	91.0	90.8	89.9
			2000		17.2		26.41	91.3	91.2	90.1
15.0	EXM254- 256/4.150DH4		1500	24.5-22.8	22.9	0.66	51.65	91.1	91.2	90.7
			1800		22.7		43.04	92.0	91.7	90.8
			2000		22.2		38.74	92.6	92.3	91.4

Table 16: 254-256 frame, low speed, 200-240V

Pn HP	Motor type	NEMA frame	Speed (RPM) min-1	Input current (I) 200-240V A	Data related to 230V					
					In A	Power factor cos (φ)	Tn lb.ft	*PDS efficiency η%		
								100	75	50
7.50	EXM254- 256/3.075DH4	254-256	1500	20.5-18.8	19.2	0.83	25.81	88.0	88.4	88.2
			1800		18.6		21.54	88.9	88.6	87.6
			2000		18		19.40	89.8	89.6	88.8
10.0	EXM254- 256/3.100DH4		1500	27.5-24.8	25.4	0.88	35.22	88.9	89.3	89.1
			1800		23.5		29.35	90.7	90.7	90.3
			2000		23.3		26.41	91.2	91.2	90.6
15.0	EXM254- 256/3.150DH4		1500	39.0-34.5	35.6	0.9	51.65	89.6	90.1	90.0
			1800		33.6		43.05	91.1	91.0	90.6
			2000		32.9		38.74	91.5	91.2	90.5

\* Please note: efficiency values shown are power-drive-system (PDS) efficiencies which include the combined losses from both the inverter and Motor. The values shown correspond to the full load range of the hydrovar X Motor. The hydrovar X Motor may operate below the minimum rated speed at partial loading.

# Terminal block hydrovar X

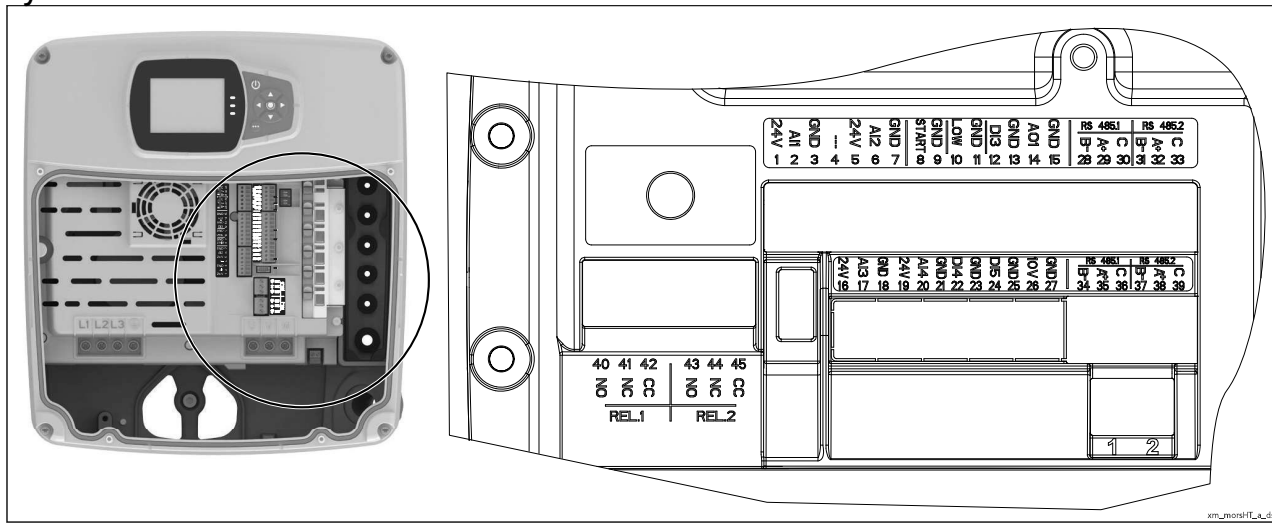

Ref.	Item	Description	Default
1		Power supply +24 VDC, max. 60mA (total, terminals 1 + 5)	
2	Analog Input 1	Configurable Analog Input 1	Pressure Sensor 1
3		Electronic GND	
4	Not used	Internal use - Do not connect	
5		Power supply +24 VDC, max. 60mA (total, terminals 1 + 5)	
6	Analog Input 2	Configurable Analog Input 2	Not used
7		Electronic GND	
8	External Start/Stop	Start/Stop digital input, +24 VDC internal pull-up, 6mA contact current	
9		Electronic GND	
10	External Lack of Water	Low water digital input, +24 VDC internal pull-up, 6mA contact current	
11		Electronic GND	
12	Digital Input 3	Configurable Digital Input 3, +24 VDC internal pull-up, 6mA contact current	Solo Run
13		Electronic GND	
14	Analog Output	Configurable Analog Output	Motor Speed
15		Electronic GND	
16		Power supply +24 VDC, max. 60mA (total, terminals 16 and 19)	
17	Analog Input 3	Configurable Analog Input 3	Not used
18		Electronic GND	
19		Power supply +24 VDC, max. 60mA (total, terminals 16 and 19)	
20	Analog Input 4	Configurable Analog Input 4	Not used
21		Electronic GND	
22	Digital Input 4	Configurable Digital Input 4, +24 VDC internal pull-up, 6mA contact current	Not used
23		Electronic GND	
24	Digital Input 5	Configurable Digital Input 5, +24 VDC internal pull-up, 6mA contact current	Not used
25		Electronic GND	
26	10 VDC supply	Power supply +10 VDC, max. 3mA	
27		Electronic GND	
28		RS485 port 1: RS485-1B N (-)	
29	Communication bus 1	RS485 port 1: RS485-1A P (+)	Multipump
30		RS485 port 1: RS485-COM	
31		RS485 port 2: RS485-2B N (-)	
32	Communication bus 2	RS485 port 2: RS485-2A P (+)	Modbus
33		RS485 port 2: RS485-COM	
34		RS485 port 1: RS485-1B N (-)	
35	Communication bus 1	RS485 port 1: RS485-1A P (+)	Multipump
36		RS485 port 1: RS485-COM	
37		RS485 port 2: RS485-2B N (-)	
38	Communication bus 2	RS485 port 2: RS485-2A P (+)	Modbus
39		RS485 port 2: RS485-COM	
40		Configurable relay 1: Normally Open	
41	Relay 1	Configurable relay 1: Normally Closed	Running
42		Configurable relay 1: Common Contact	
43		Configurable relay 2: Normally Open	
44	Relay 2	Configurable relay 2: Normally Closed	Error
45		Configurable relay 2: Common Contact	

# How to read smart pump series curves

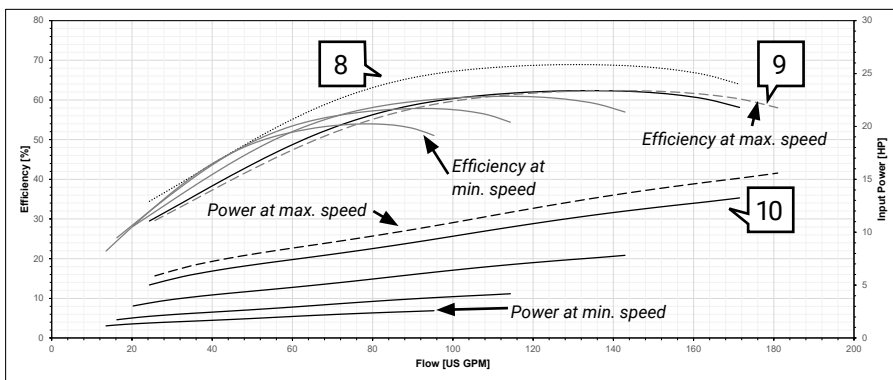
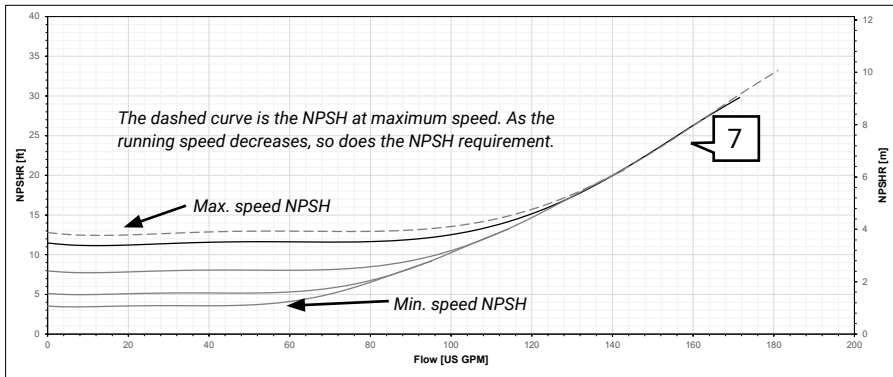
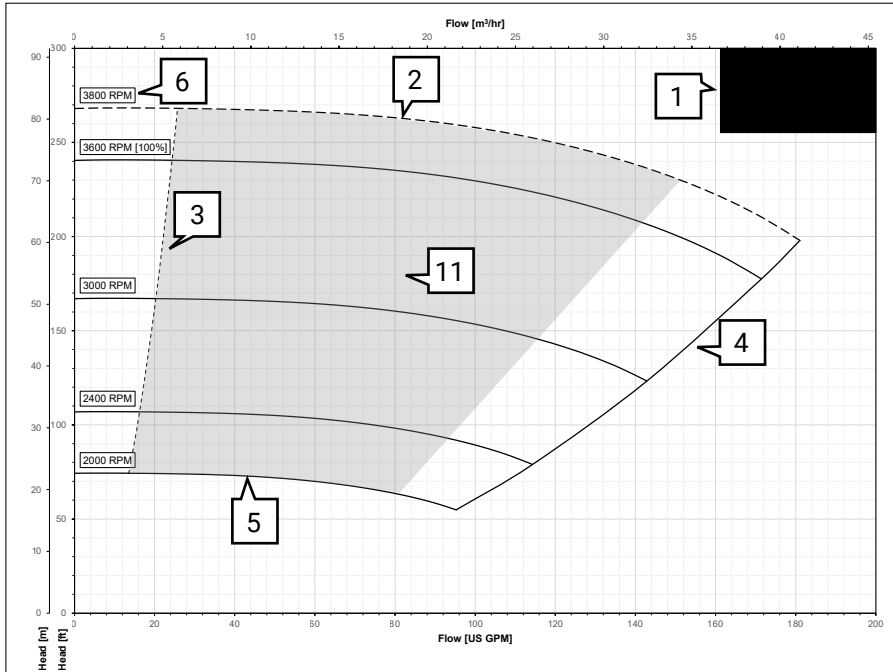

1. **Model information:** pump model and motor information.
2. **Maximum speed curve:** the maximum operating speed of the pump. Any speed above the nominal speed rating (i.e. 1800 RPM or 3600 RPM) is indicated by a dashed line.
3. **Minimum continuous stable flow:** the recommended minimum flow rate of the pump.
4. **Maximum flow curve:** the recommended maximum flow rate of the pump.
5. **Minimum speed curve:** the minimum operating speed of the pump for continuous operation.
6. **speed tags:** indicate the Motor speed of a given performance curve. The [100%] modifier indicates the default maximum speed setting of the motor.
7. **NPSH curve:** the net positive suction head required of the pump.
8. **Pump efficiency curve:** the standalone efficiency of the pump operating at the [100%] speed condition.
9. **Efficiency overall:** the overall efficiency (wire-to-water efficiency) of the pump and motor per speed. **Note:** efficiency curves for each speed are shown in descending order where lower speeds result in lower efficiency.
10. **Input power:** the input power required to drive the motor by speed.
11. **Sensorless working area:** the shaded area on the performance curve indicates the sensorless operating area.

# Sensorless selection strategy and limitations

## How and where sensorless works

When opting for sensorless operation, it is critical to understand the reliable zone of operation for each specific pump model and how it interacts with the control curve. The reliable zone of operation is the shaded area overlaid on the performance curve. The control curve is the system curve that the drive defines based on the duty point and minimum head input by the user. Note that the control curve is not the true system curve, rather a simple approximation. See diagram below:

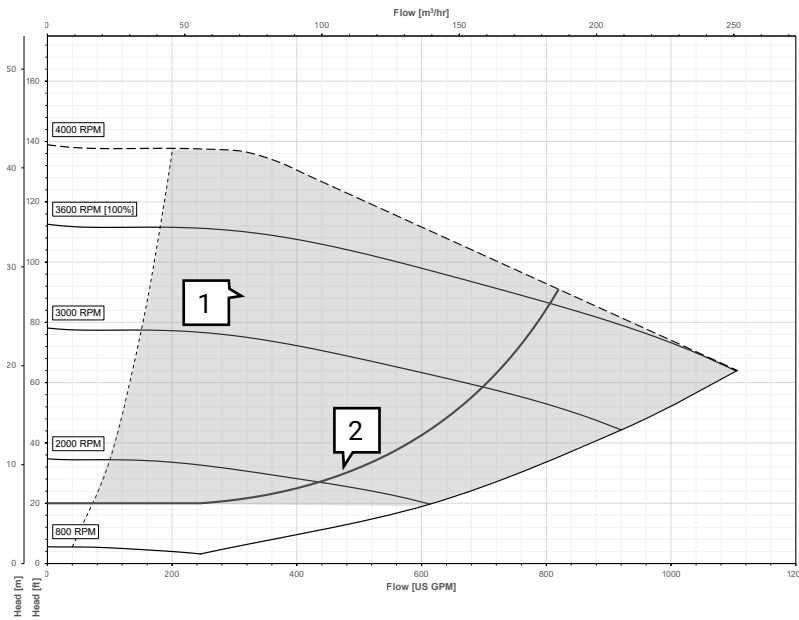

1. **Sensorless operating area**  
(reliable zone of operation)
2. **Control curve**

The control curve may have two possible shapes: linear (proportional pressure control) or quadratic (quadratic pressure control). The type of control that should be used depends on the duty point, expected flow operating range, accuracy needed, and minimum head required. It is up to the user to choose the control strategy that best suits their system while keeping in mind general limitations of sensorless operation.

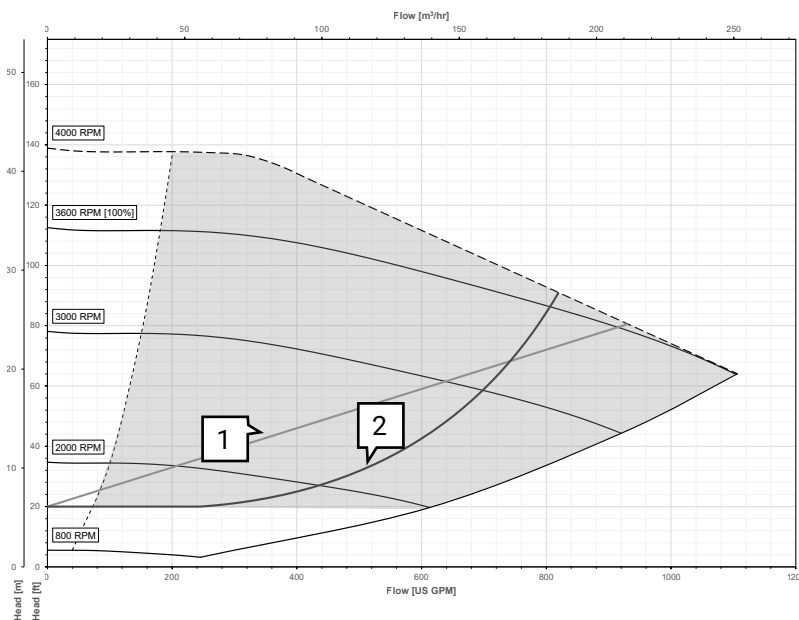

1. **Linear control curve**  
(Proportional pressure control mode)
2. **Quadratic control curve**  
(Quadratic pressure control mode)

### How is the exact shape of the control curve created?

The hydrovar X drive uses the input duty point and minimum head to draw a control curve between both points and then extends the curve towards a maximum speed setpoint. The maximum speed setpoint is located at the intersection of the control curve and the maximum speed curve. See example below:

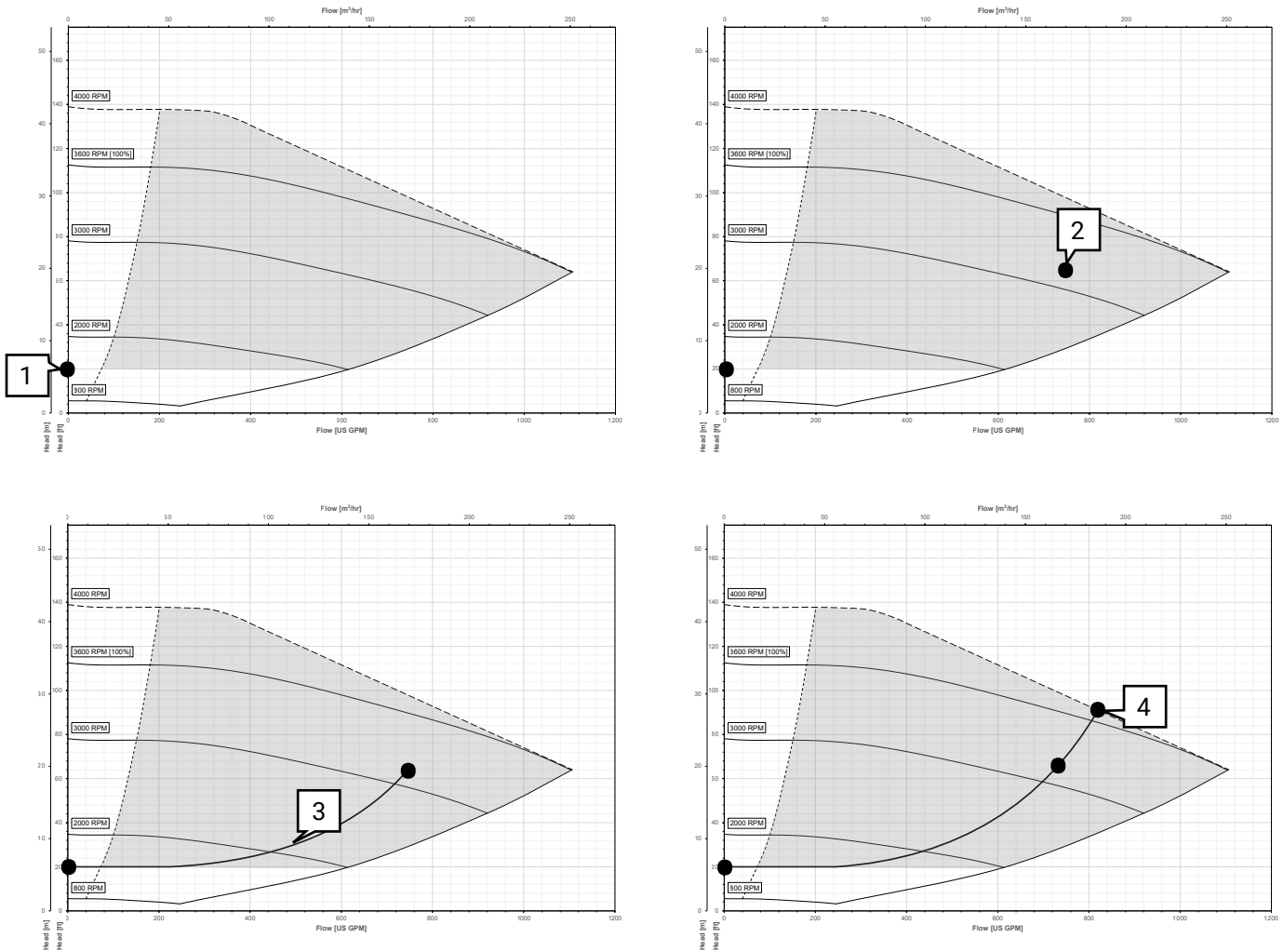

1. User sets the zero flow minimum head.
2. User sets the duty point head and flow.
3. The hydrovar X drive will evaluate if the input values are within the sensorless range and draw a curve between both points based on whether the user selected proportional or quadratic control (quadratic control is depicted in the example).
4. The hydrovar X drive will establish the maximum speed setpoint at the intersection of the max speed curve and the control curve. This concludes the control curve setup.

## Sensorless selection scenarios and best practices

For reliable operation, the entire control curve must fit within the reliable zone of operation. Examples below show various selection scenarios highlighting the limitations of sensorless operation:

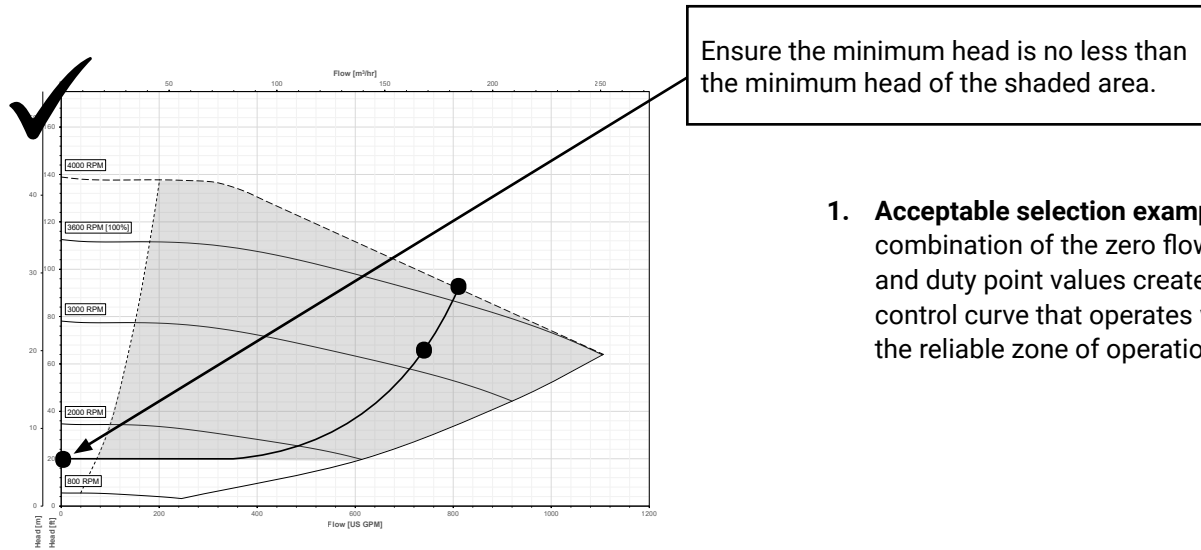

1. **Acceptable selection example:** The combination of the zero flow head and duty point values created a control curve that operates within the reliable zone of operation.

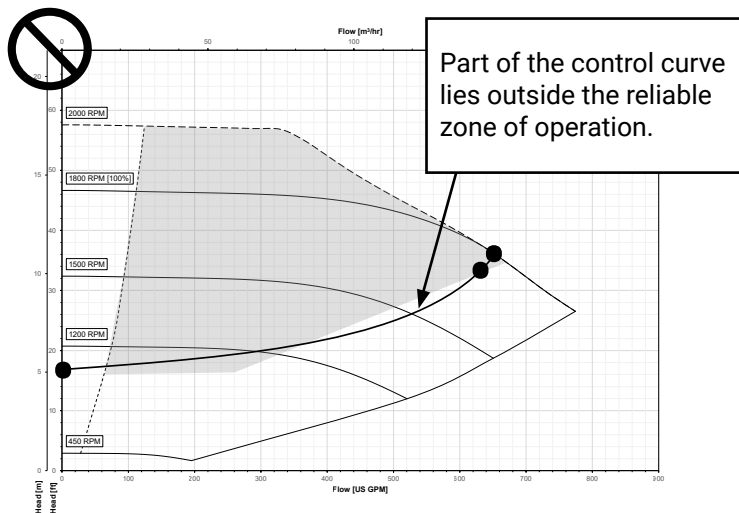

2. **Poor selection:** Placing a duty point near the maximum flow range of the reliable zone of operation and selecting a low head value for zero flow while using quadratic control may create a control curve that lies outside of the shaded region. Such a selection will create control instability along the control curve.

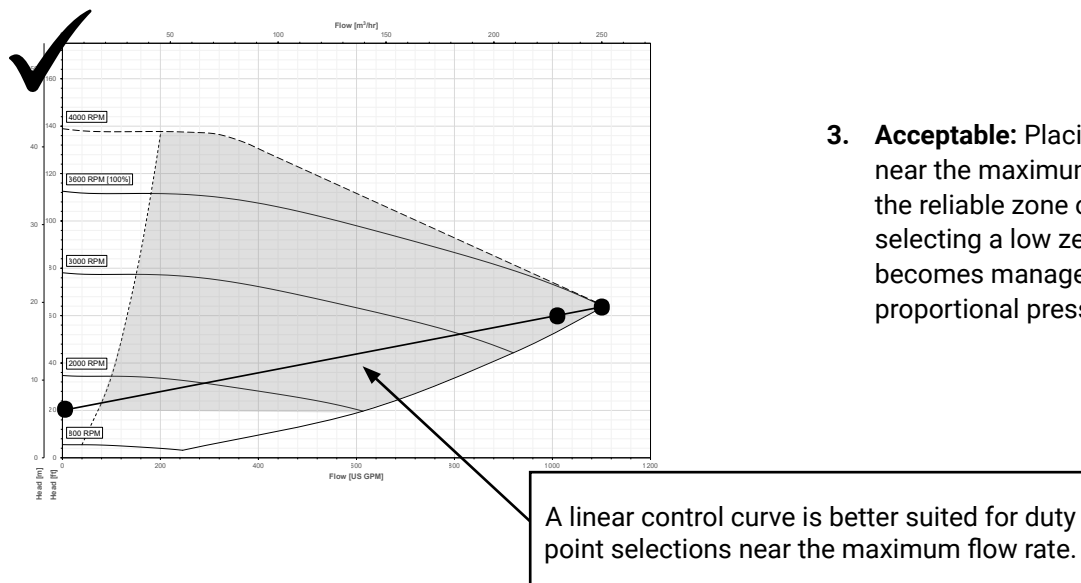

3. **Acceptable:** Placing a duty point near the maximum flow rate of the reliable zone of operation and selecting a low zero-flow head value becomes manageable with linear proportional pressure control.

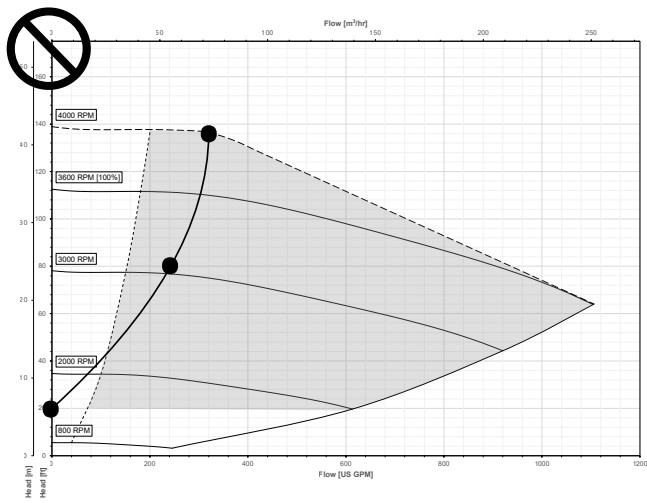

4. **Poor selection example:** Even though the control curve lies within the reliable zone of operation, it is best to avoid unnecessarily steep control curves. Steep curves may cause dramatic changes in pressure over small changes in flow leading to system instability.

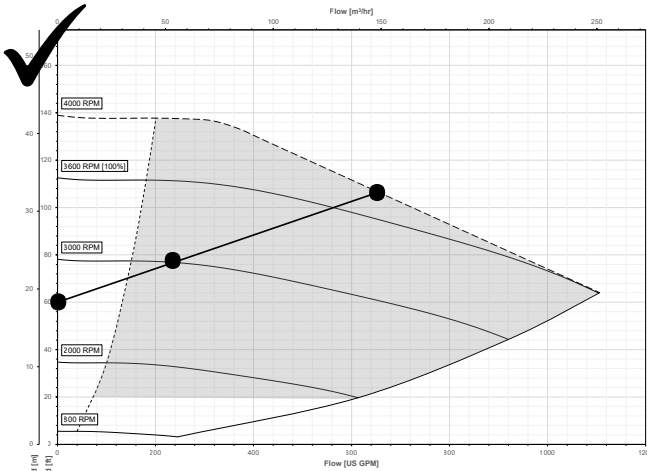

5. For duty points at high head and low flow, it is best to utilize a linear control curve with a raised minimum head value.

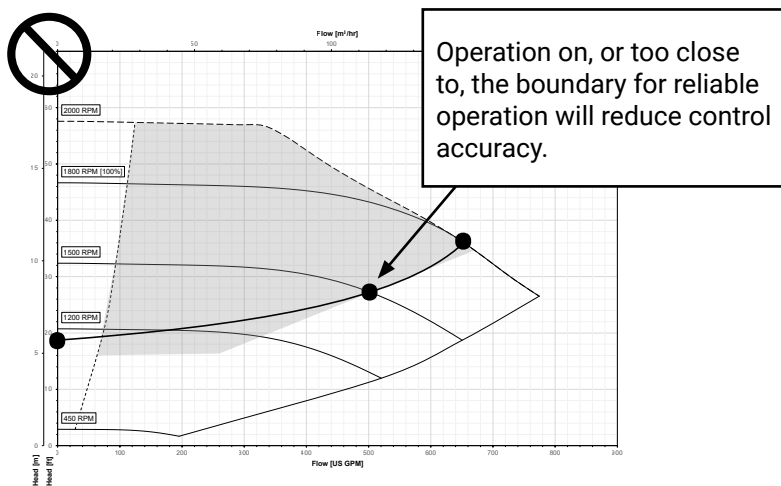

6. **Poor selection example:** Even though the control curve lies within the reliable zone of operation, it is best to avoid having the control curve operate near the boundary of sensorless operation. At the boundary, the drive will lose control accuracy which may cause system instability.

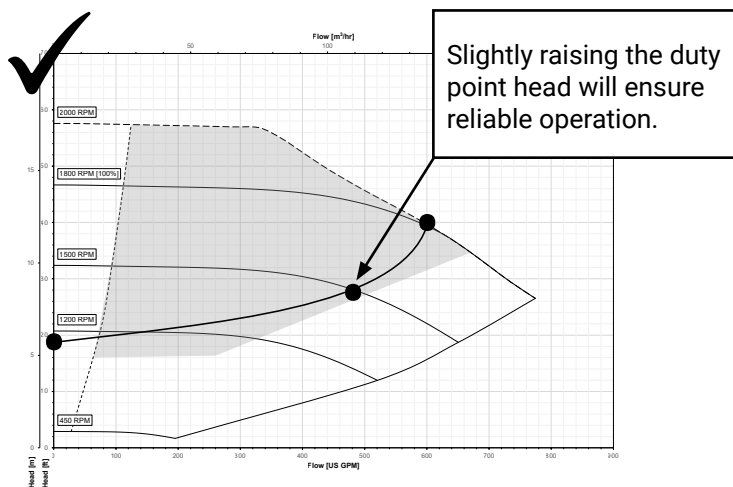

7. **Acceptable selection example:** Slightly raising the duty point shifts the control curve upward, moving it well within the reliable zone of operation.

## Sensorless minimum and maximum speed regulation behavior

**Maximum speed regulation:** The smart pump will always ensure continuous operation does not occur above the user-defined maximum speed. If the smart pump reaches maximum speed while under sensorless operation, the control curve will begin to follow the maximum speed limit curve until either the flow demand reduces or the maximum flow rate allowed by the system is met. (see left-side figure below). If the flow demand exceeds the maximum flow rate of the reliable zone of operation, sensorless control will lose accuracy and become unstable. It is recommended to implement flow limiting measures that align with the maximum flow rate of the reliable zone of operation. If the user lowers the maximum speed parameter, the control curve will still follow its original path until it reaches the new maximum speed curve. From that point, the control curve will path along the new maximum speed curve. (see right-side figure below).

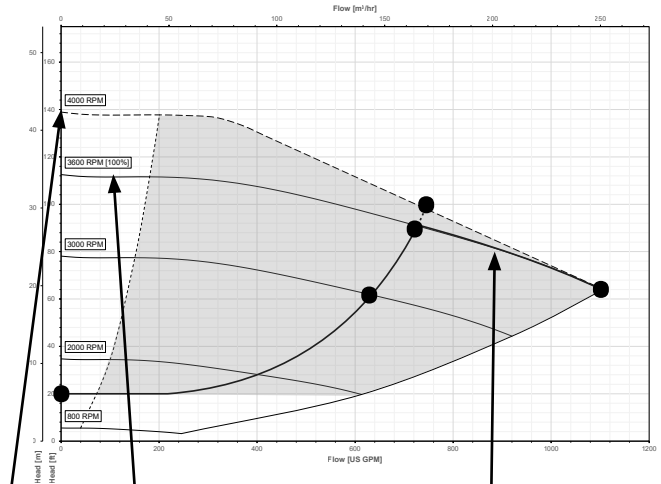
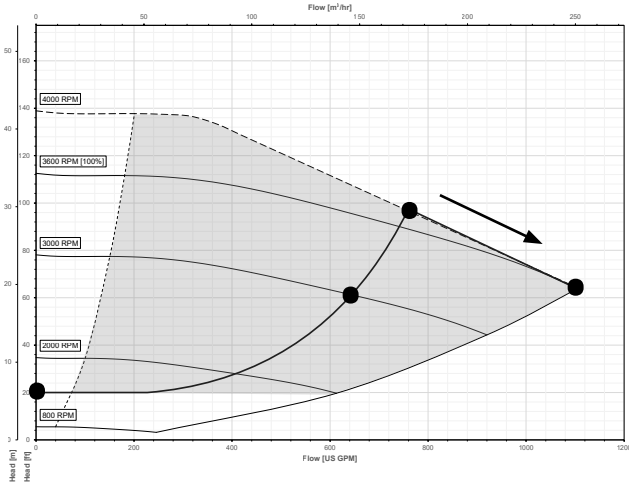

User changes maximum speed from 4000 to 3600 RPM.

Control curve will follow new maximum speed curve once 3600 RPM is reached.

**Minimum speed regulation:** The smart pump will always ensure continuous operation does not occur below the user-defined minimum speed. In sensorless control, the minimum head may be set below the minimum speed provided that the user-defined minimum head is no less than the minimum head of the reliable zone of operation (shaded area). The control curve is always defined by the user-input minimum head and duty point; however, the control path will follow along the minimum speed curve that is programmed into the drive by the user. See figure below:

1. User changes minimum speed from 800 RPM to 2000 RPM.

2. User sets minimum head below the new minimum speed of 2000 RPM. Note the minimum head is still within the shaded region's pressure range.

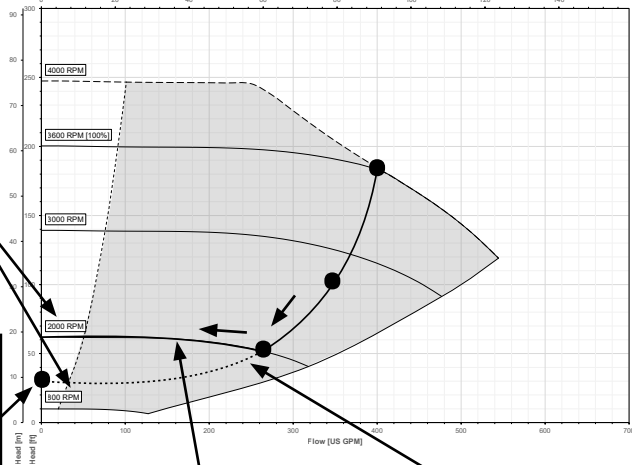

4. Control curve will follow the new minimum speed performance curve at low flow rates.

3. Control curve will no longer operate along the dotted line at low flow rates.

**Warning:** sensorless operation does not include lack of water detection and protection. The smart pump system should be paired with an external stop signal to protect the pump from operating conditions that force the pump to operate below the minimum flow rate.

# Performance curves

## Series e-80SCX performance curves for high speed models - 460V

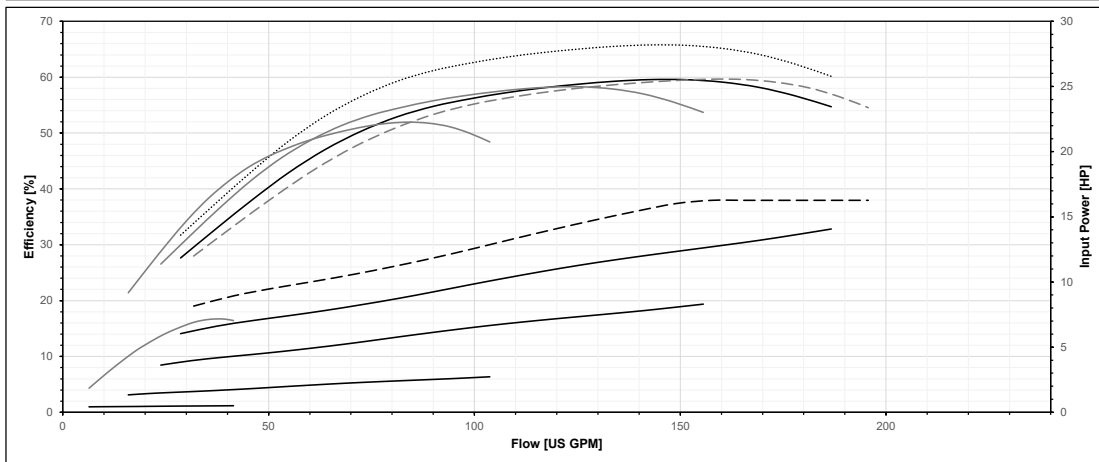
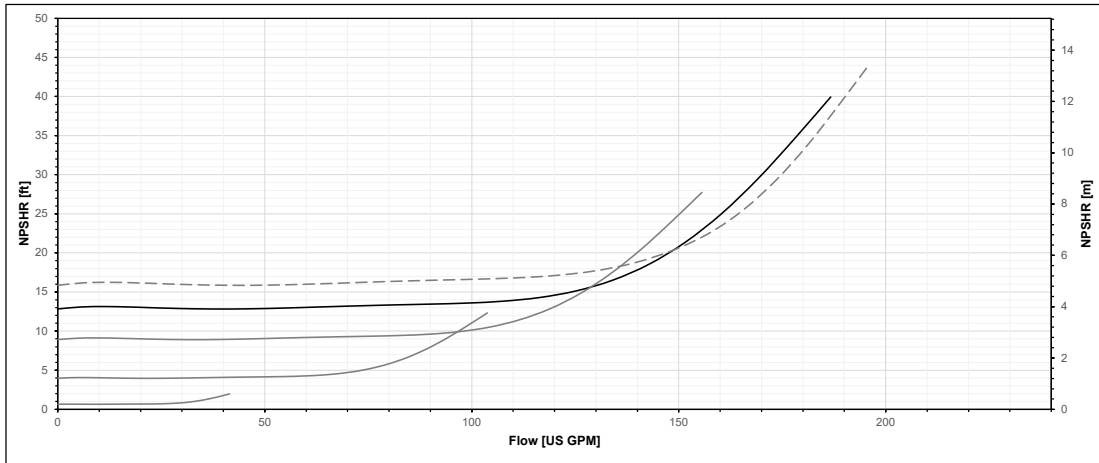
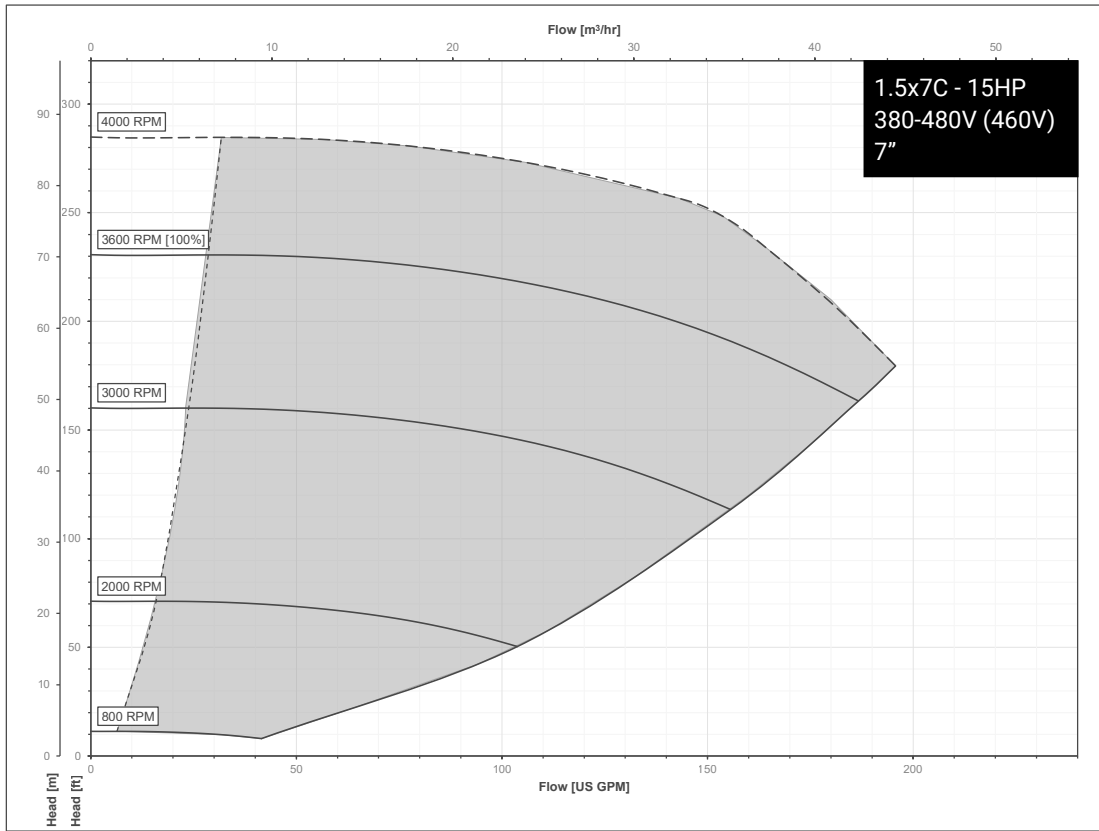

# Series e-80SCX performance curves for high speed models - 460V

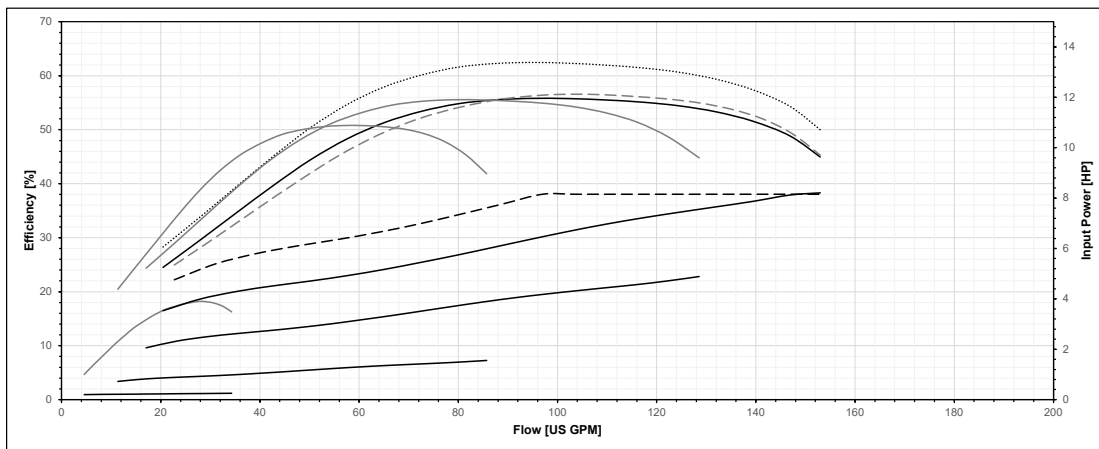
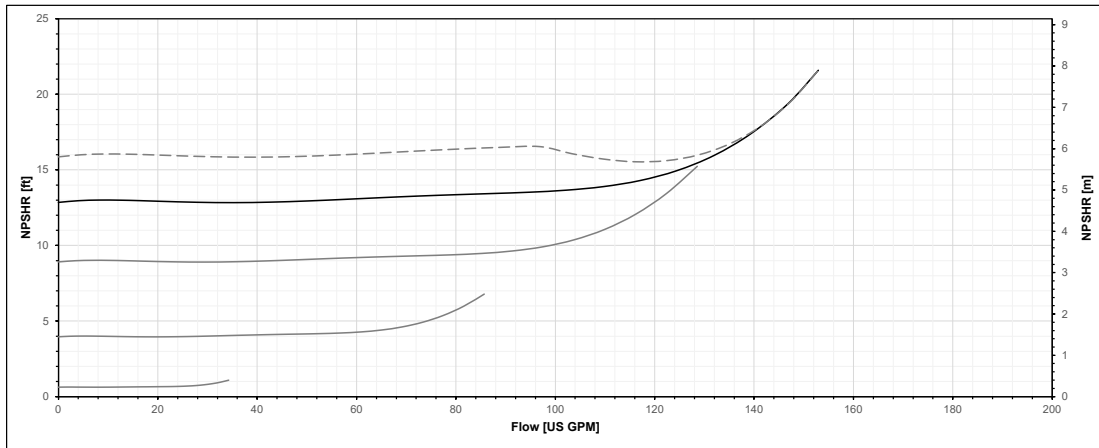
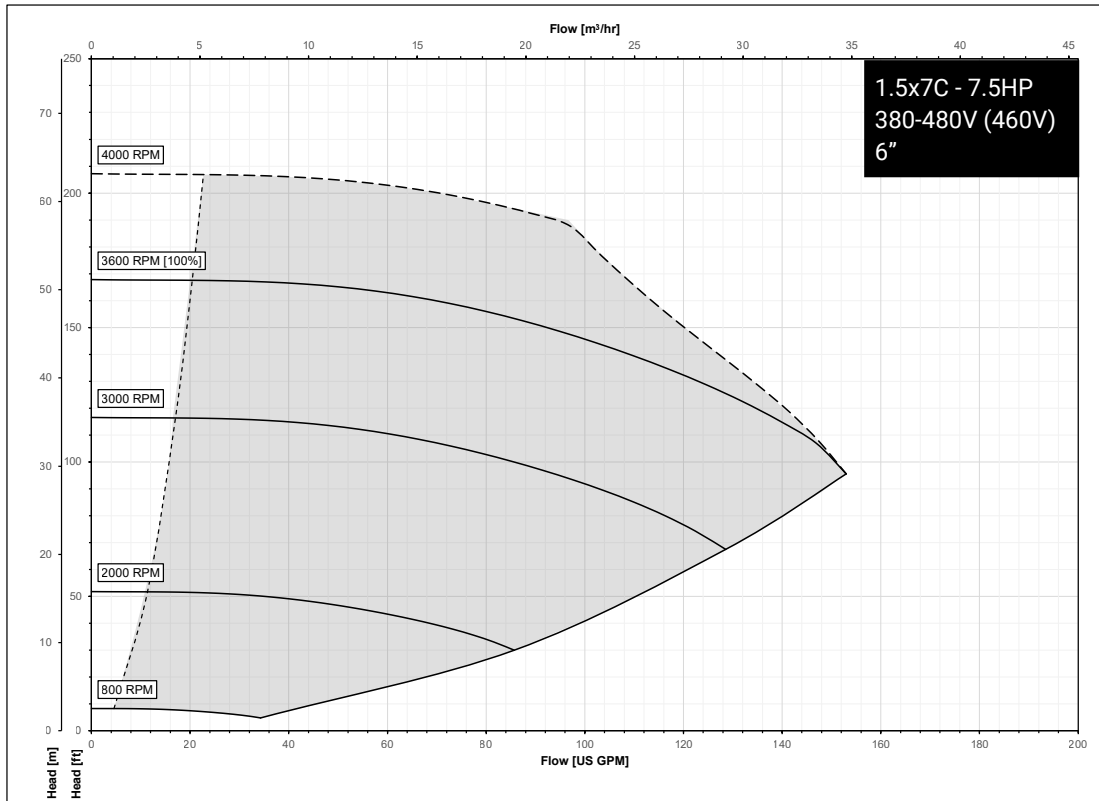

## Series e-80SCX performance curves for high speed models - 460V

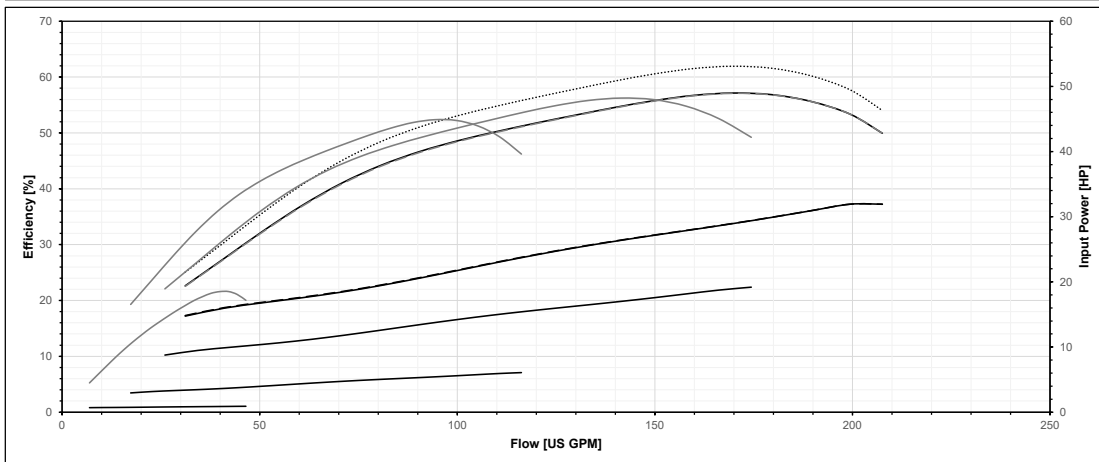
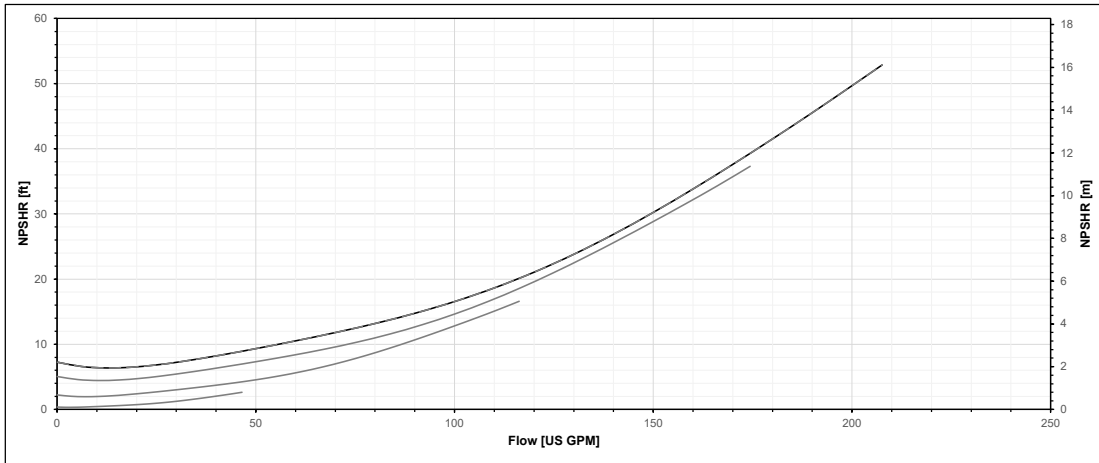
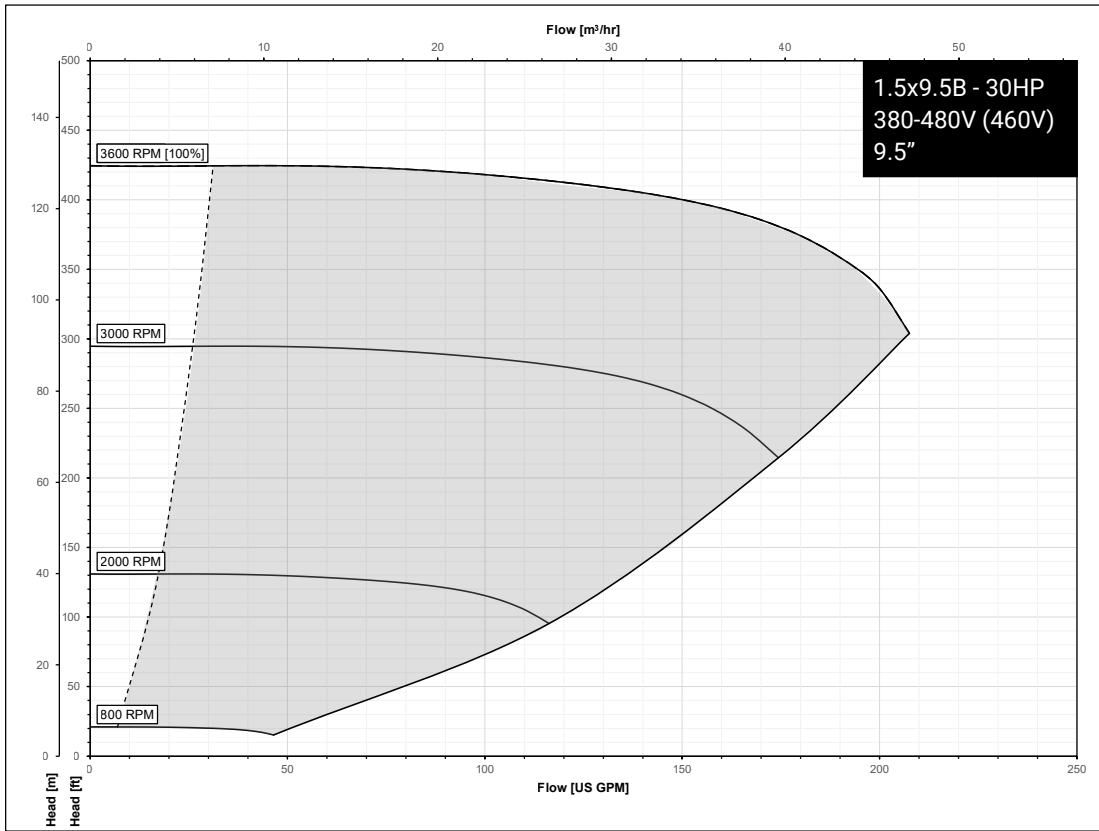

# Series e-80SCX performance curves for high speed models - 460V

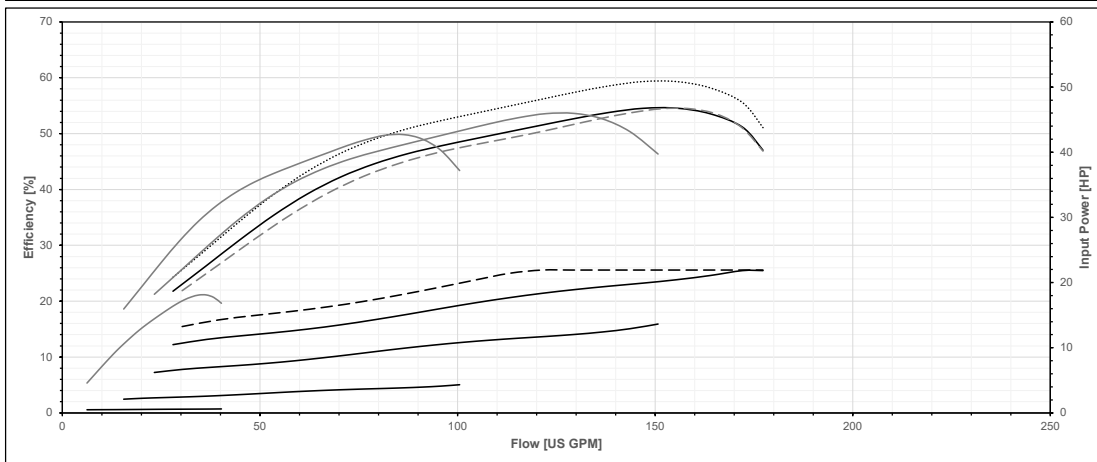
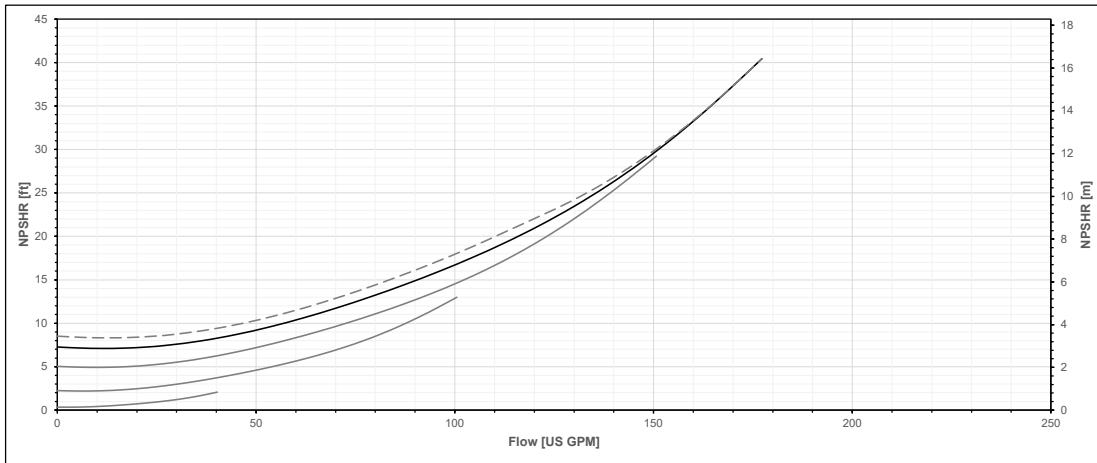
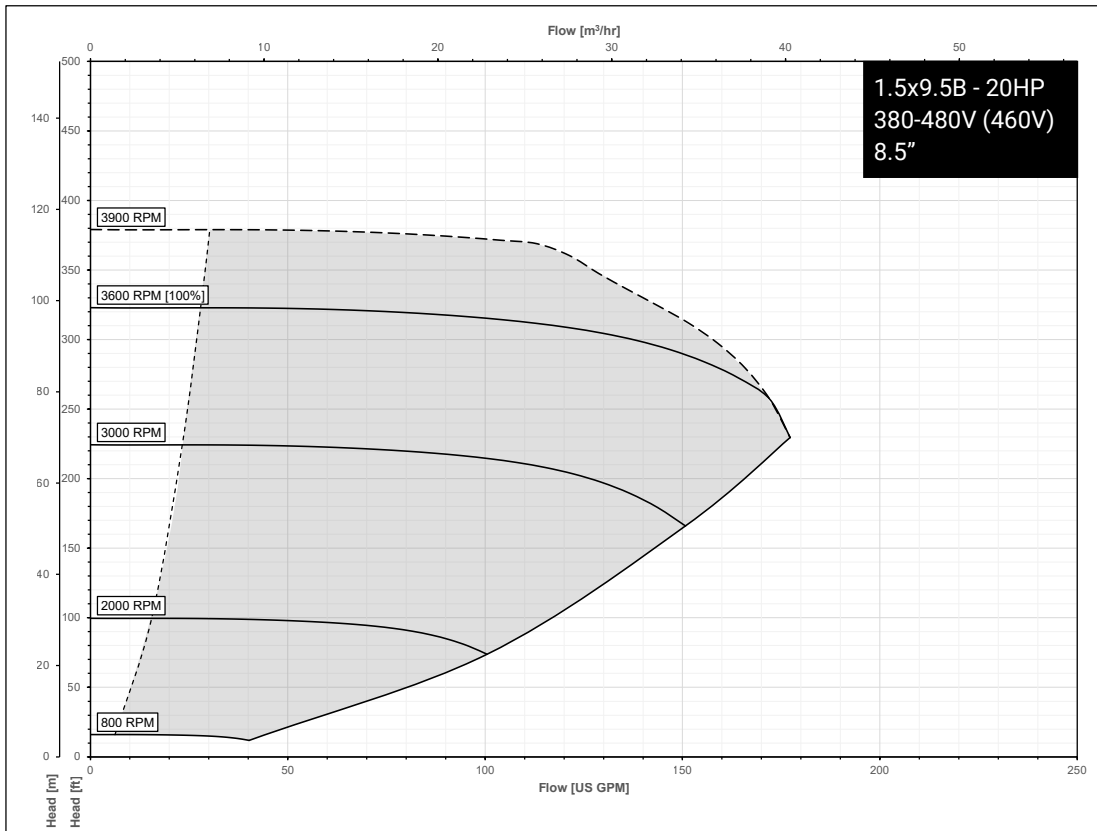

# Series e-80SCX performance curves for high speed models - 460V

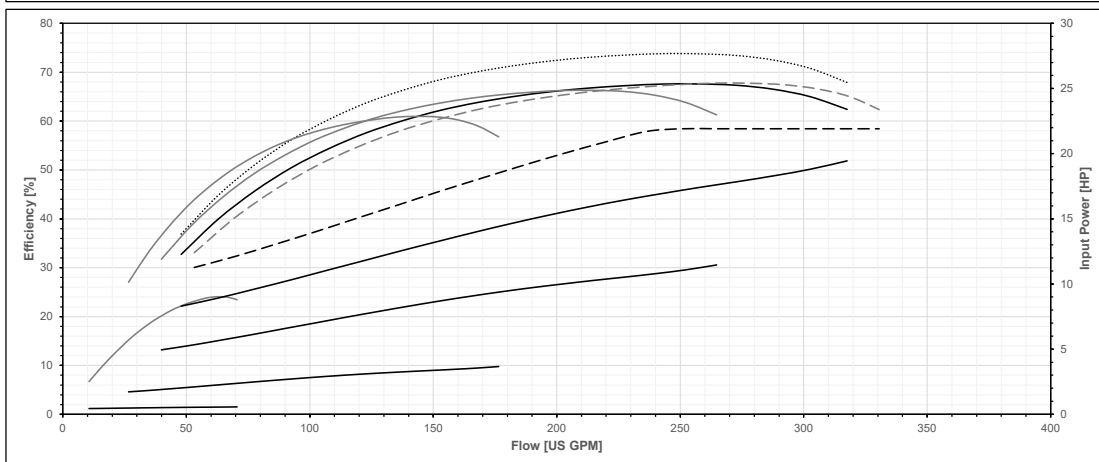
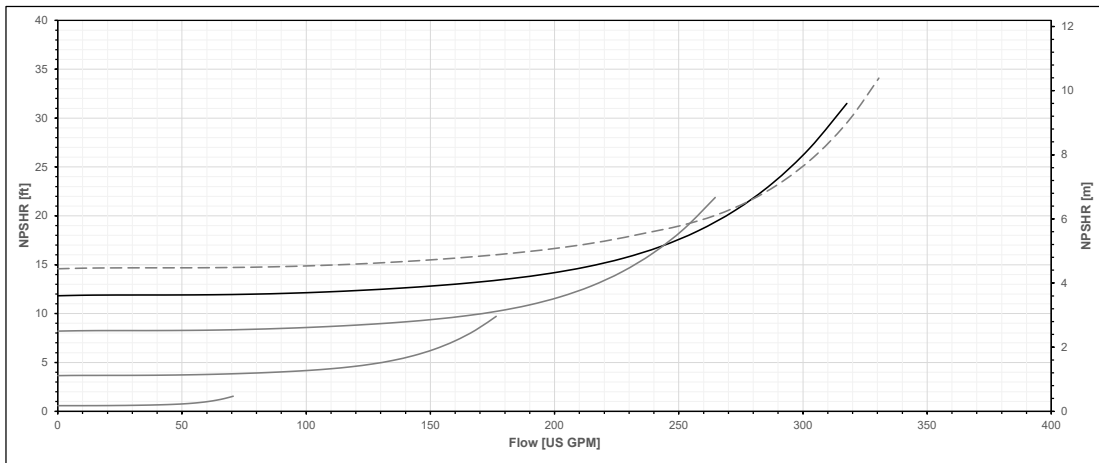
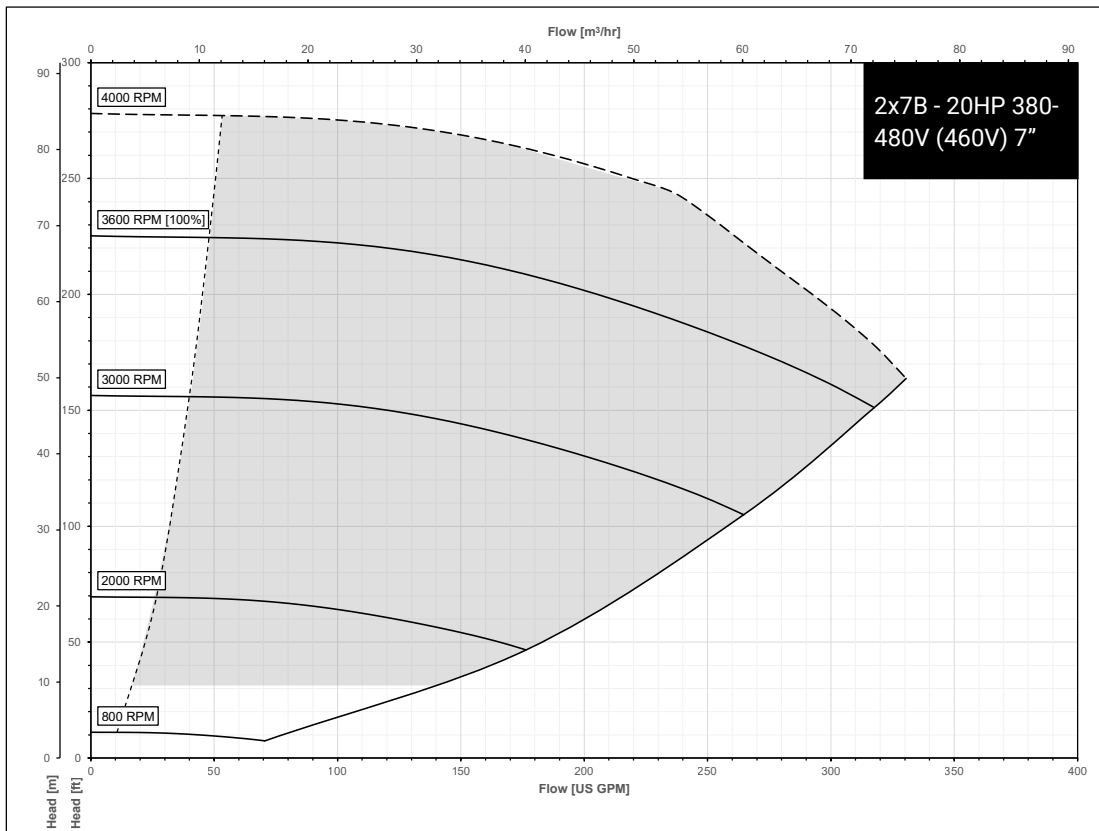

# Series e-80SCX performance curves for high speed models - 460V

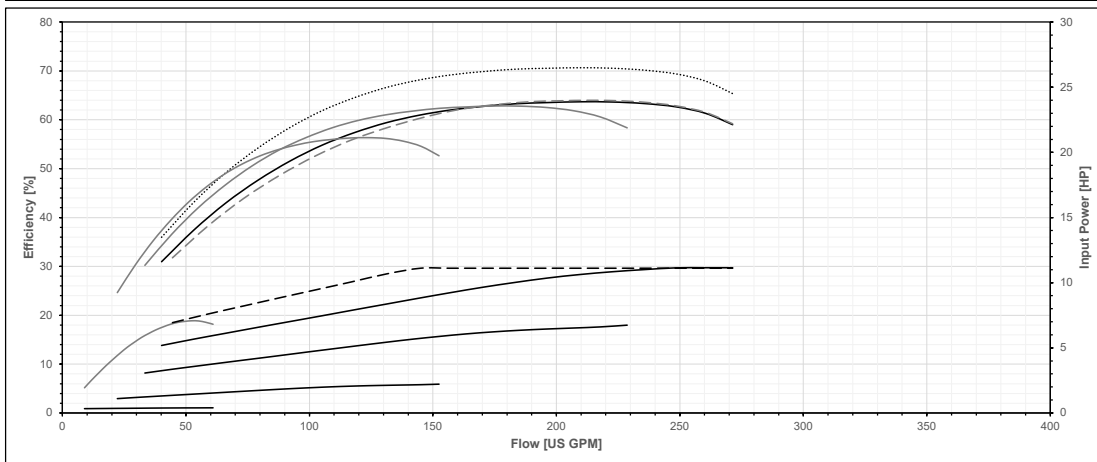
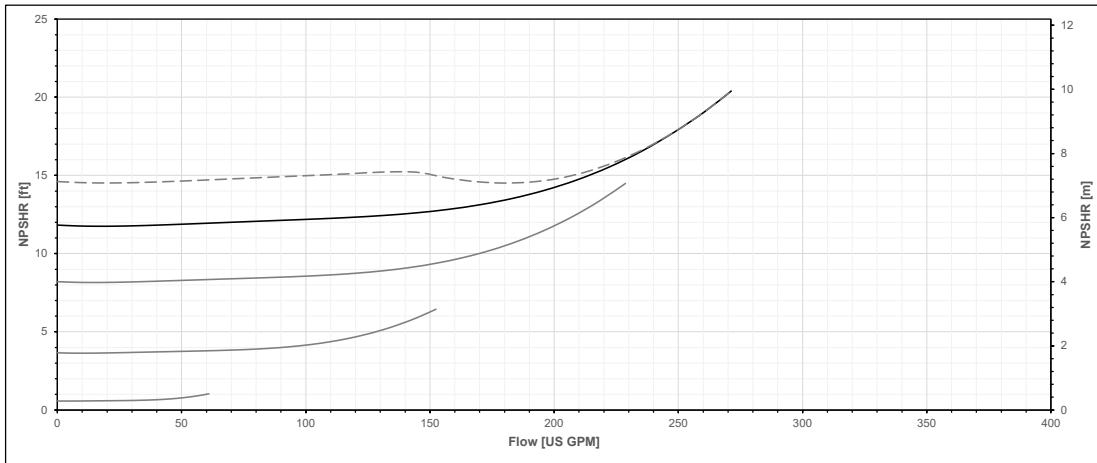
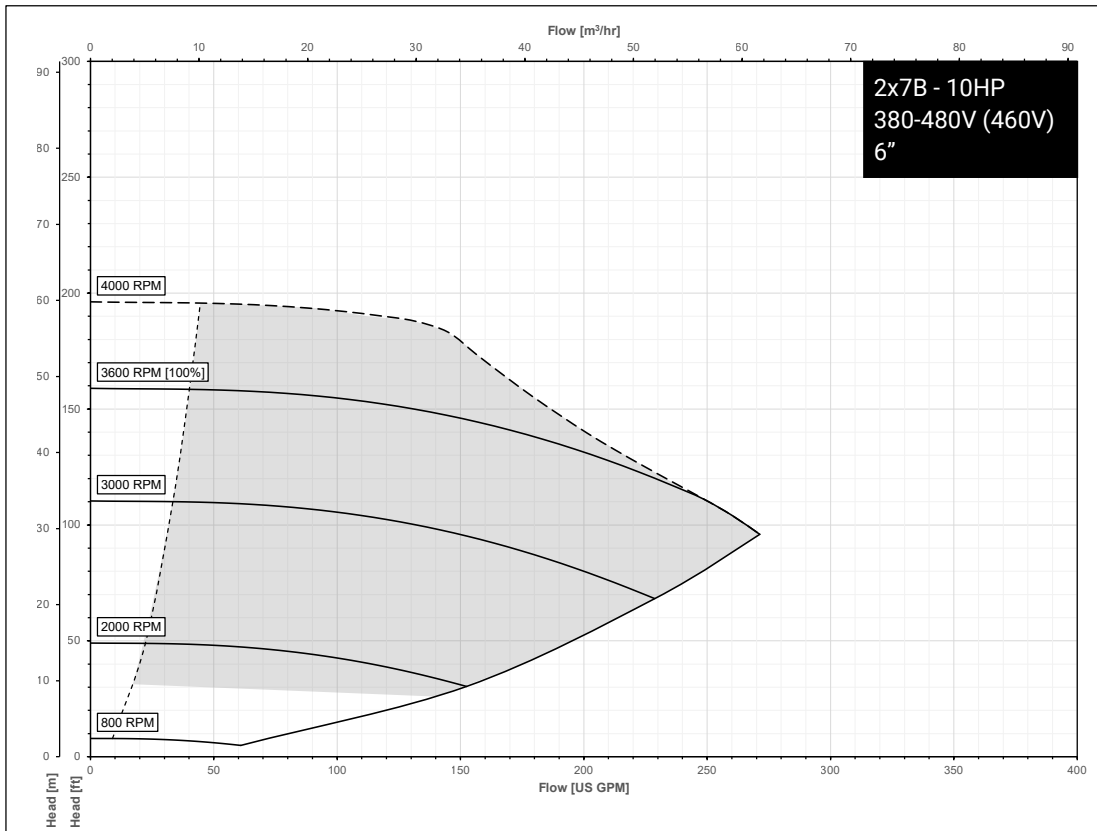

# Series e-80SCX performance curves for high speed models - 460V

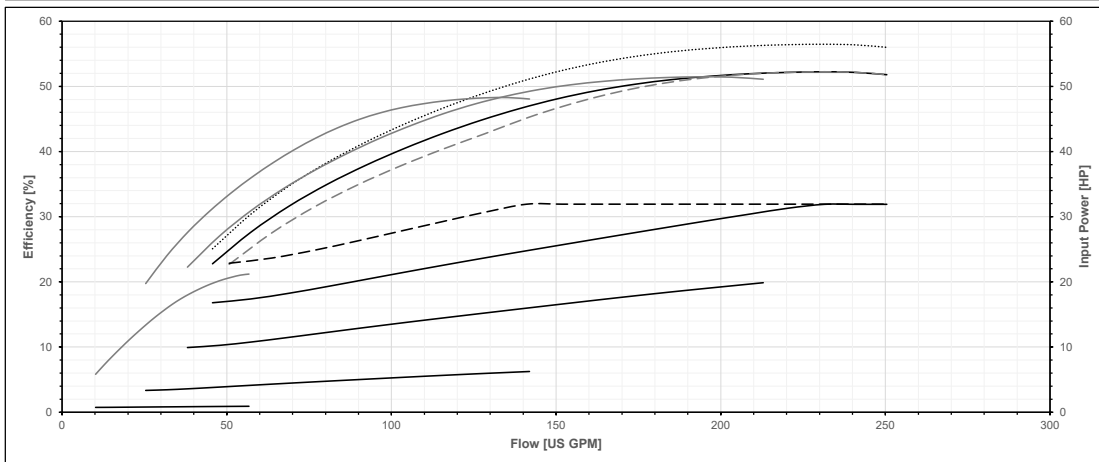
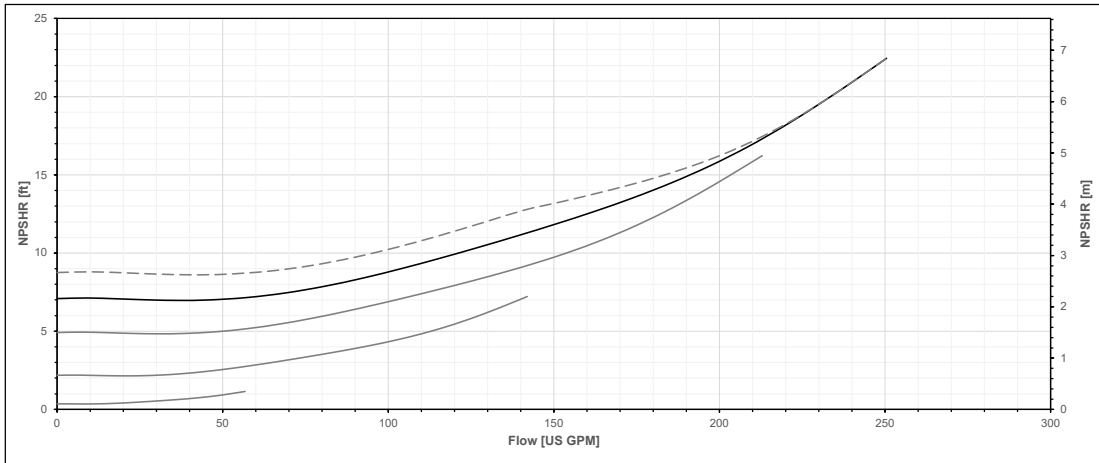
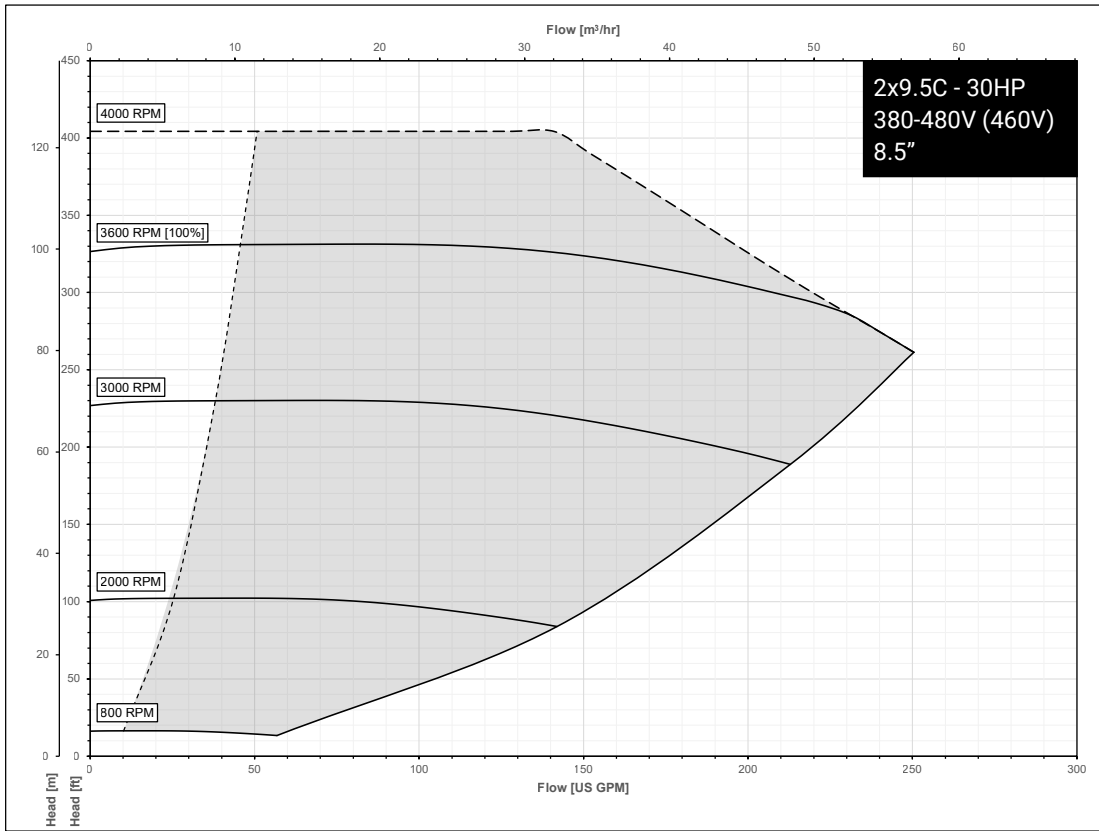

# Series e-80SCX performance curves for high speed models - 460V

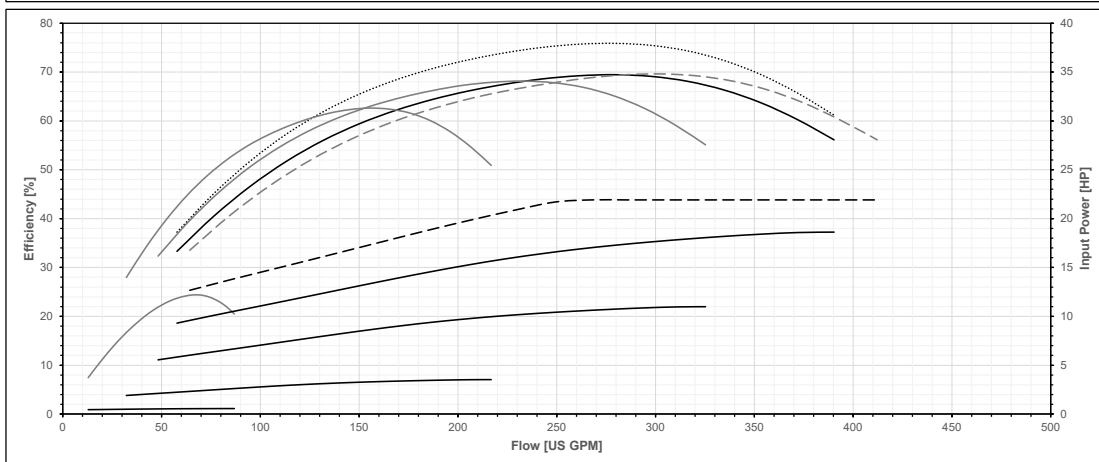
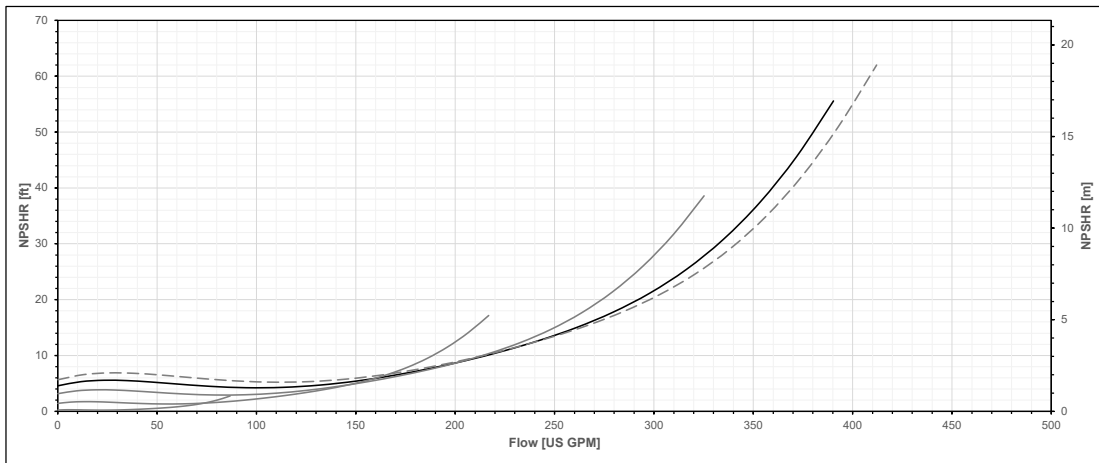
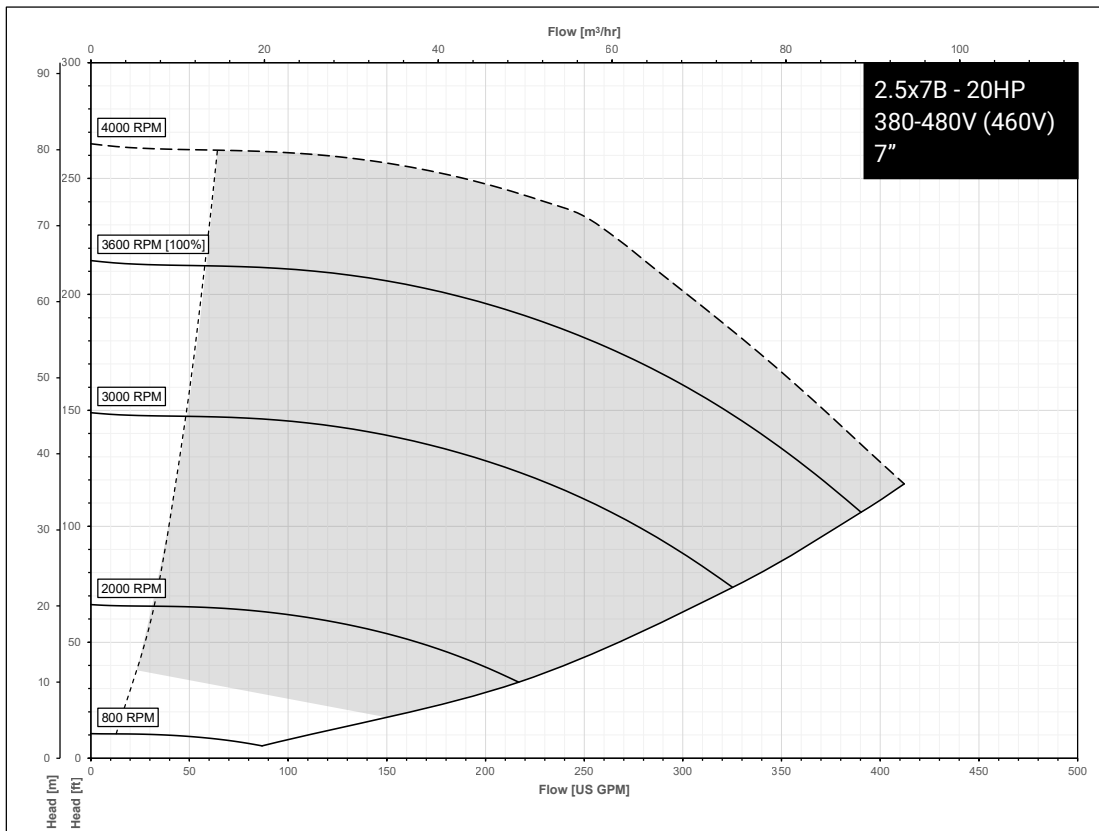

# Series e-80SCX performance curves for high speed models - 460V

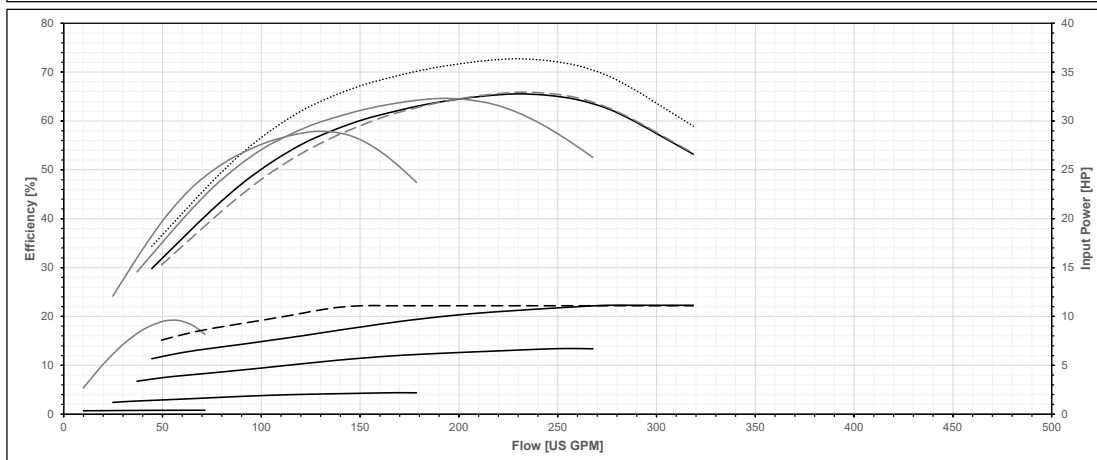
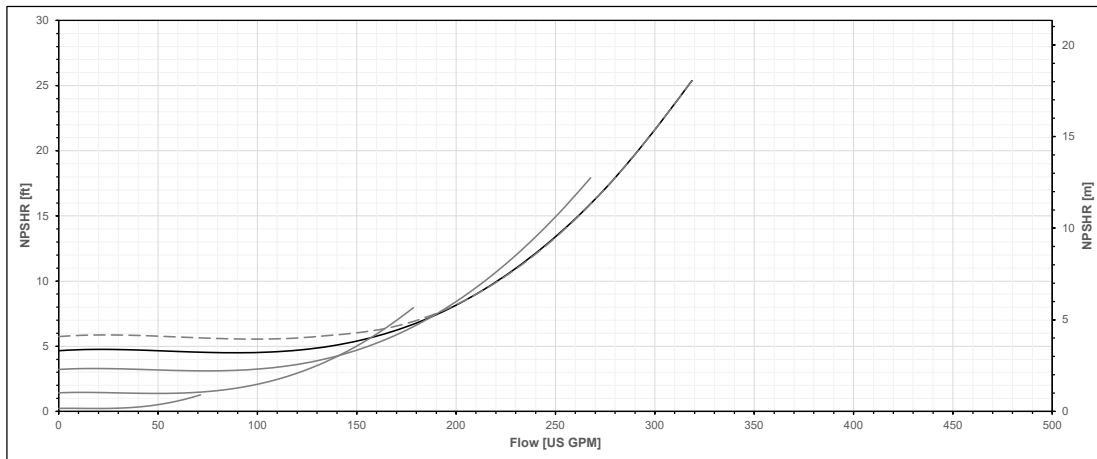
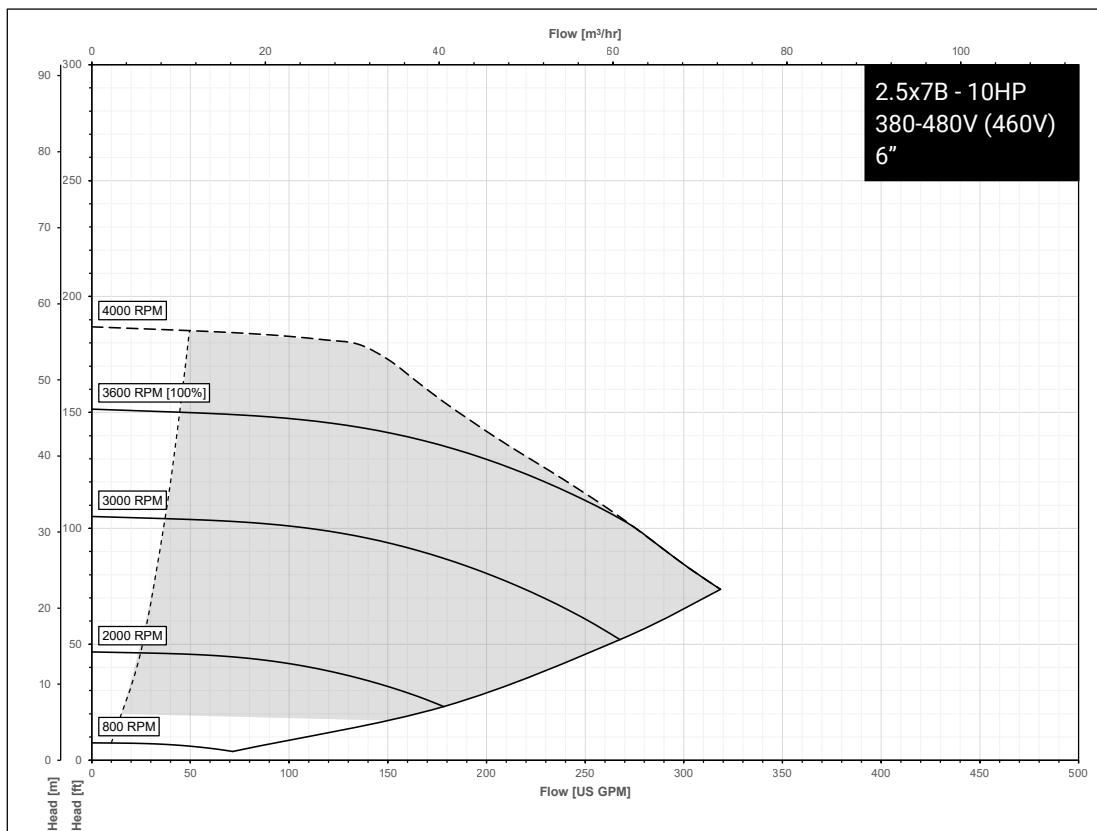

# Series e-80SCX performance curves for high speed models - 460V

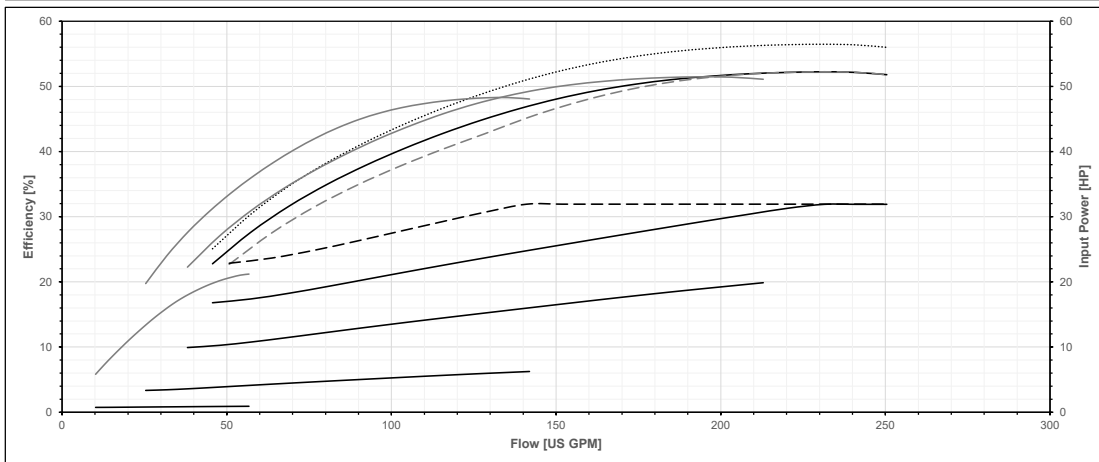
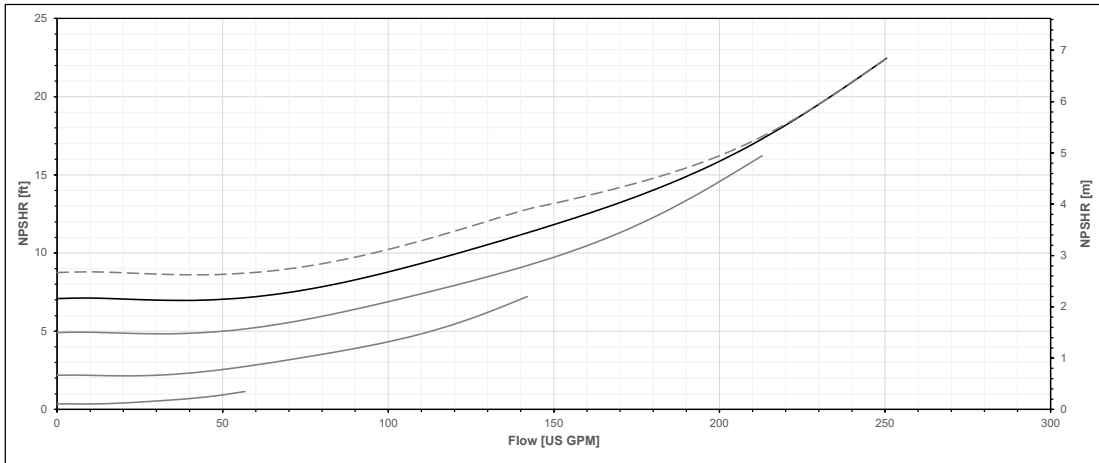
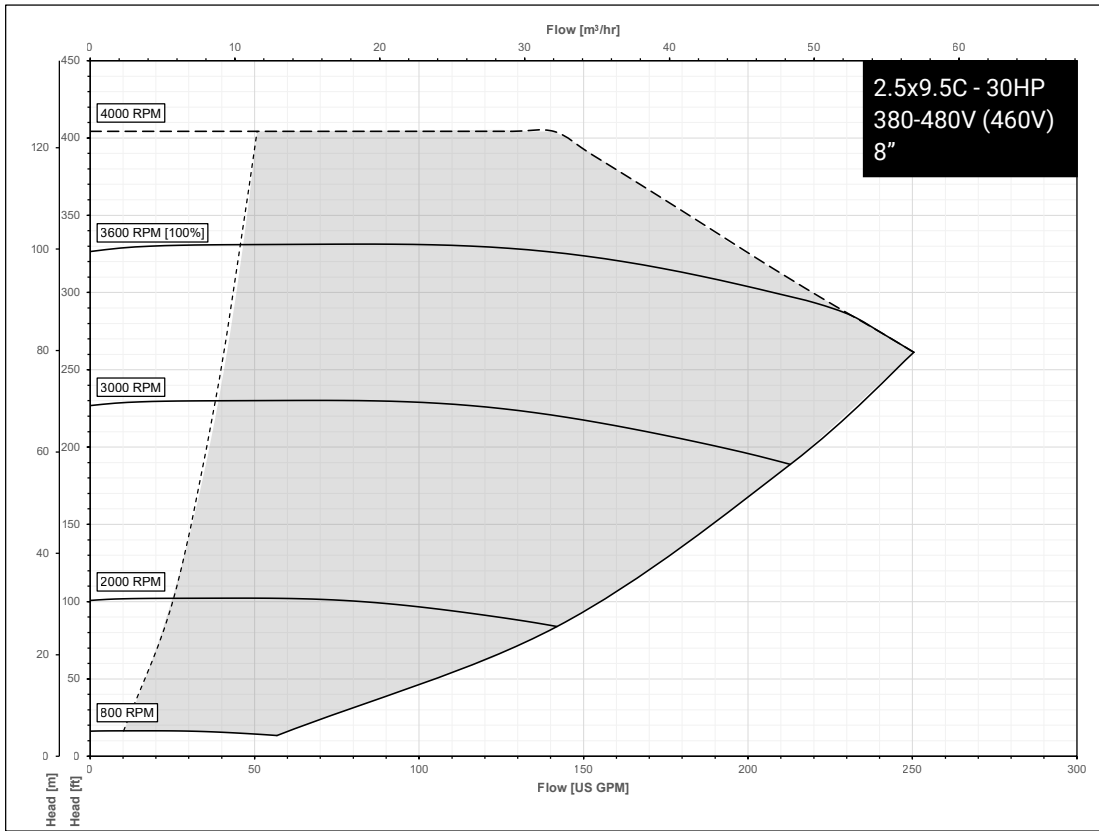

# Series e-80SCX performance curves for high speed models - 460V

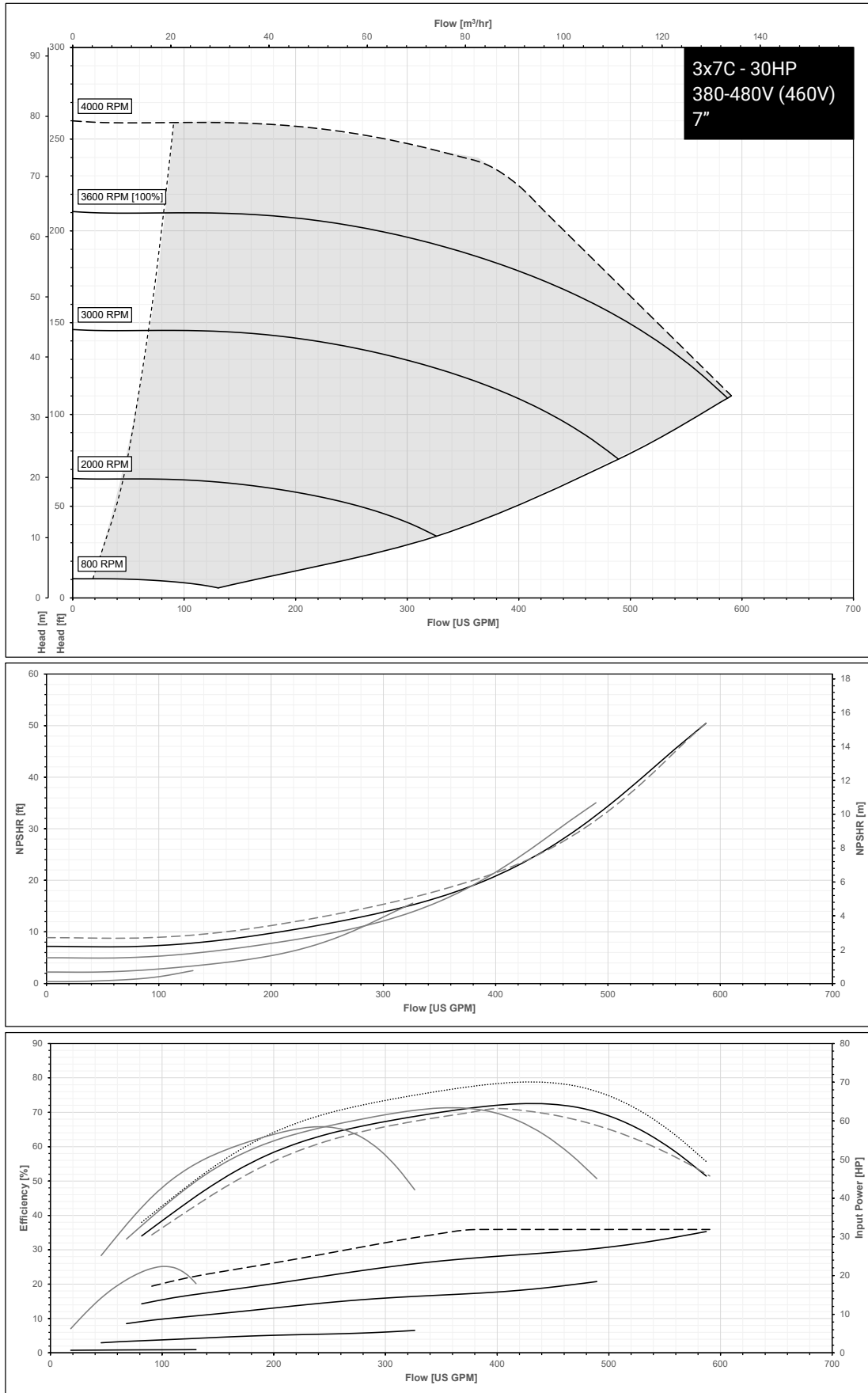

# Series e-80SCX performance curves for high speed models - 460V

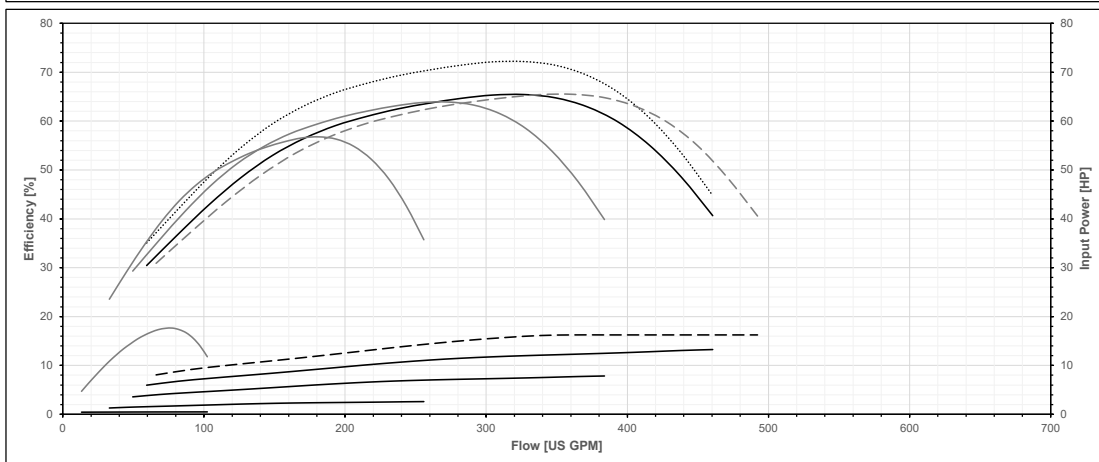
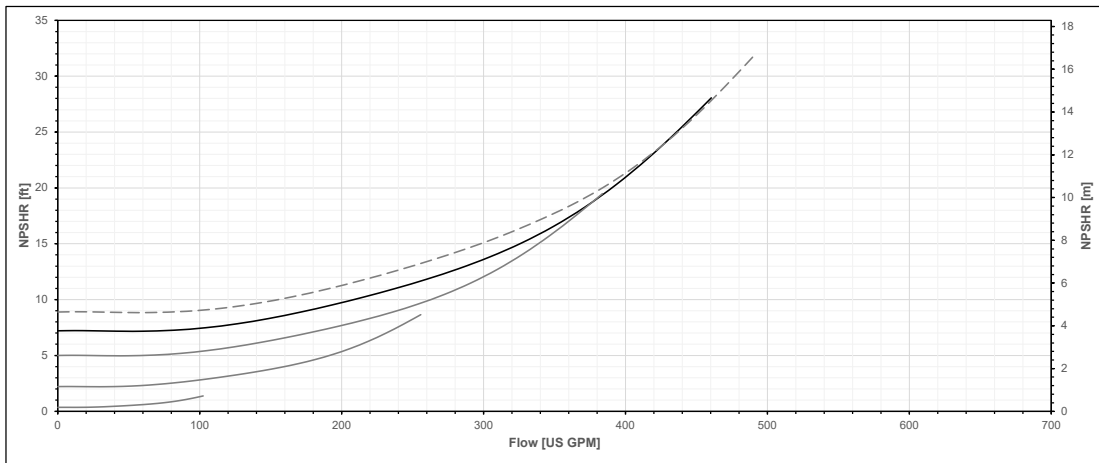
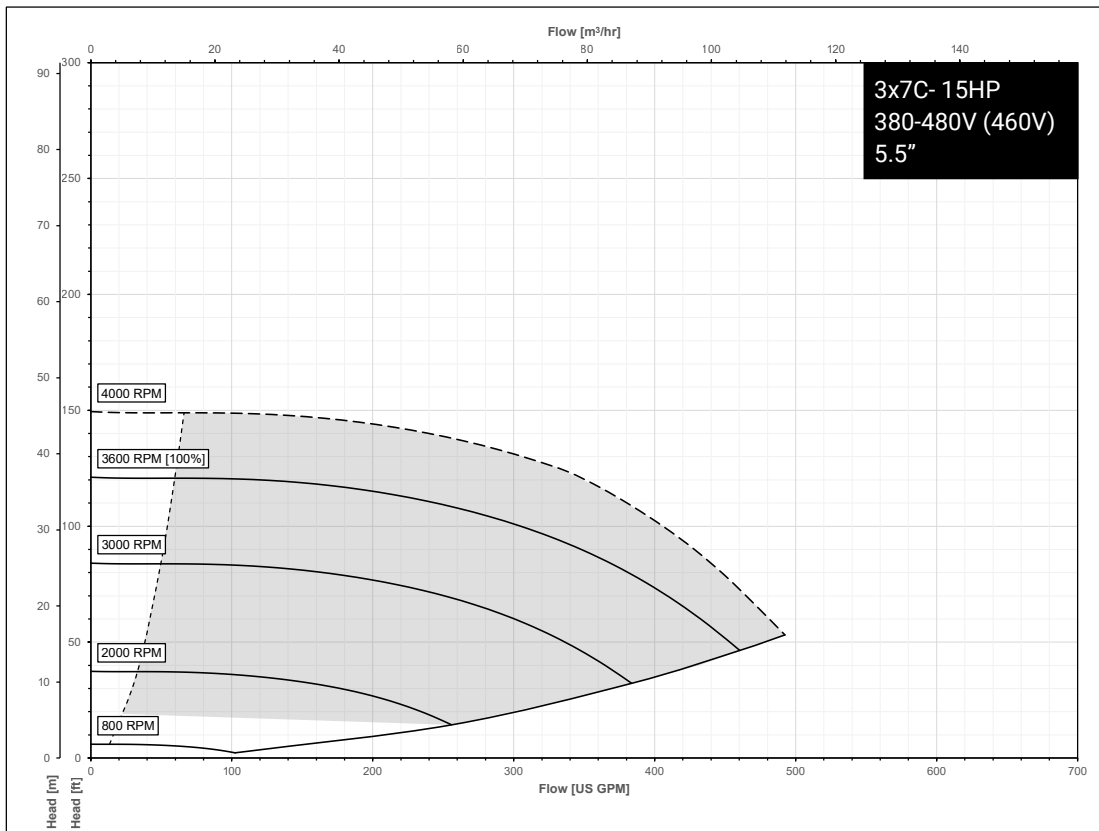

# Series e-80SCX performance curves for high speed models - 460V

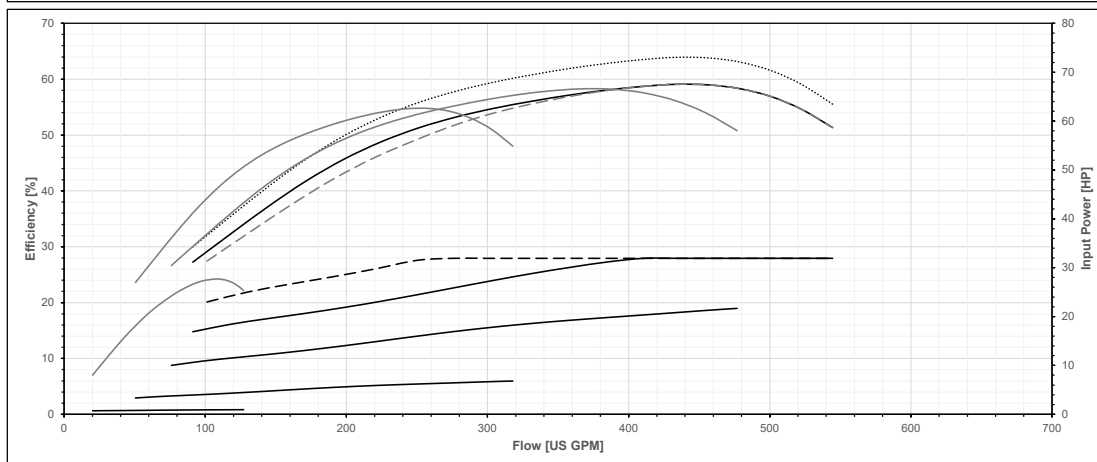
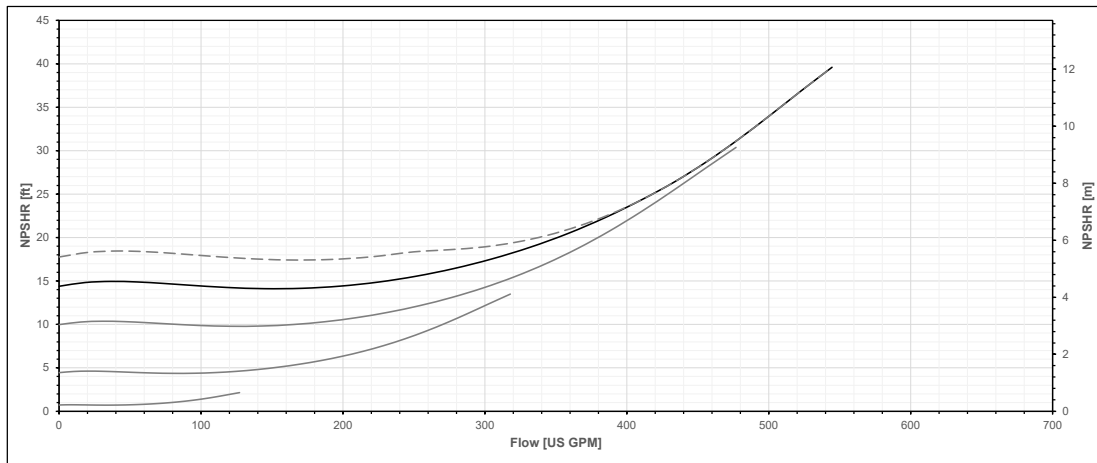
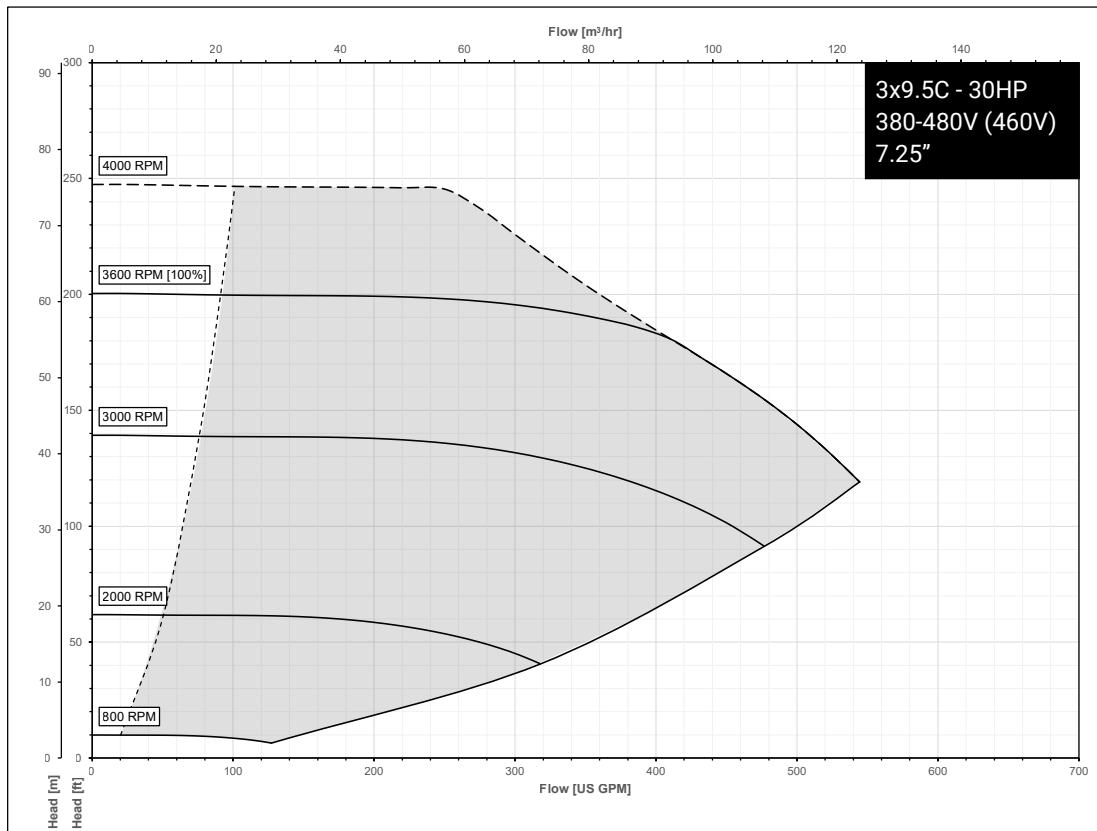

# Series e-80SCX performance curves for high speed models - 460V

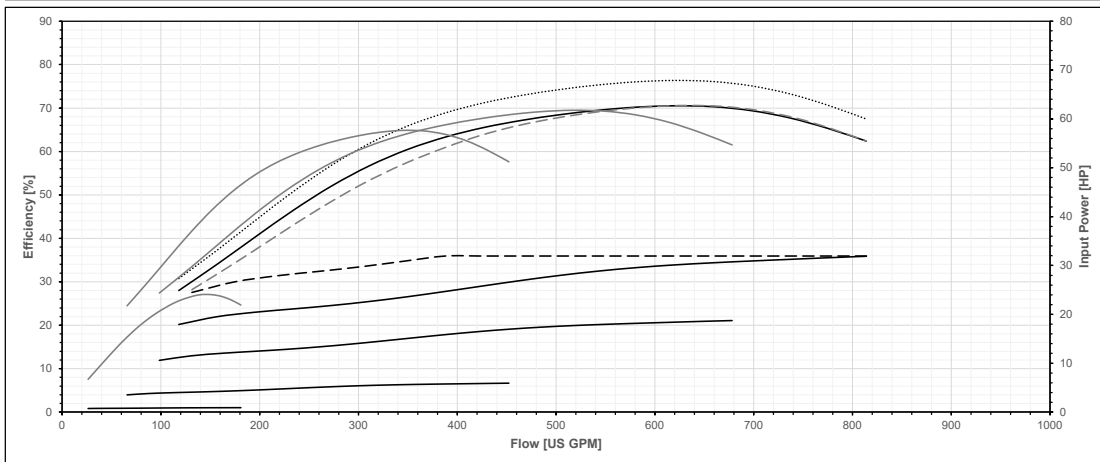
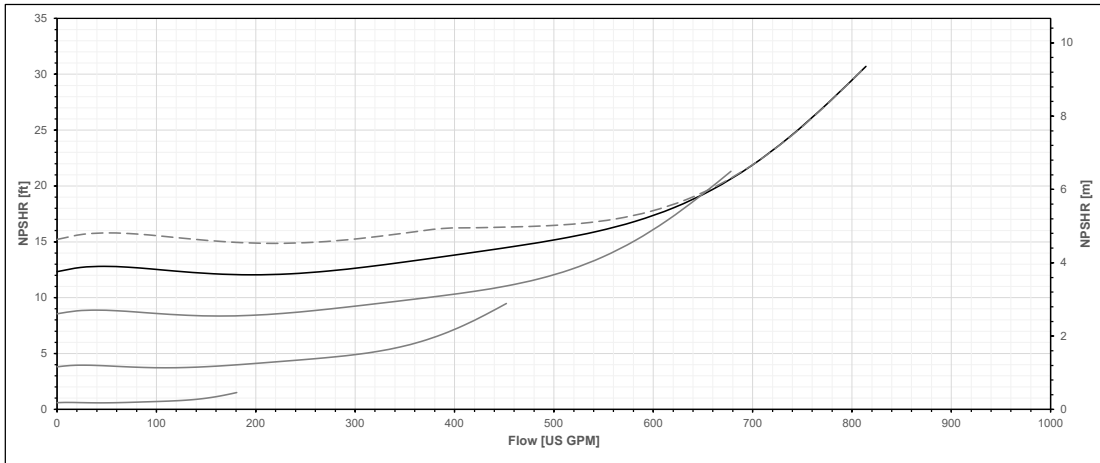
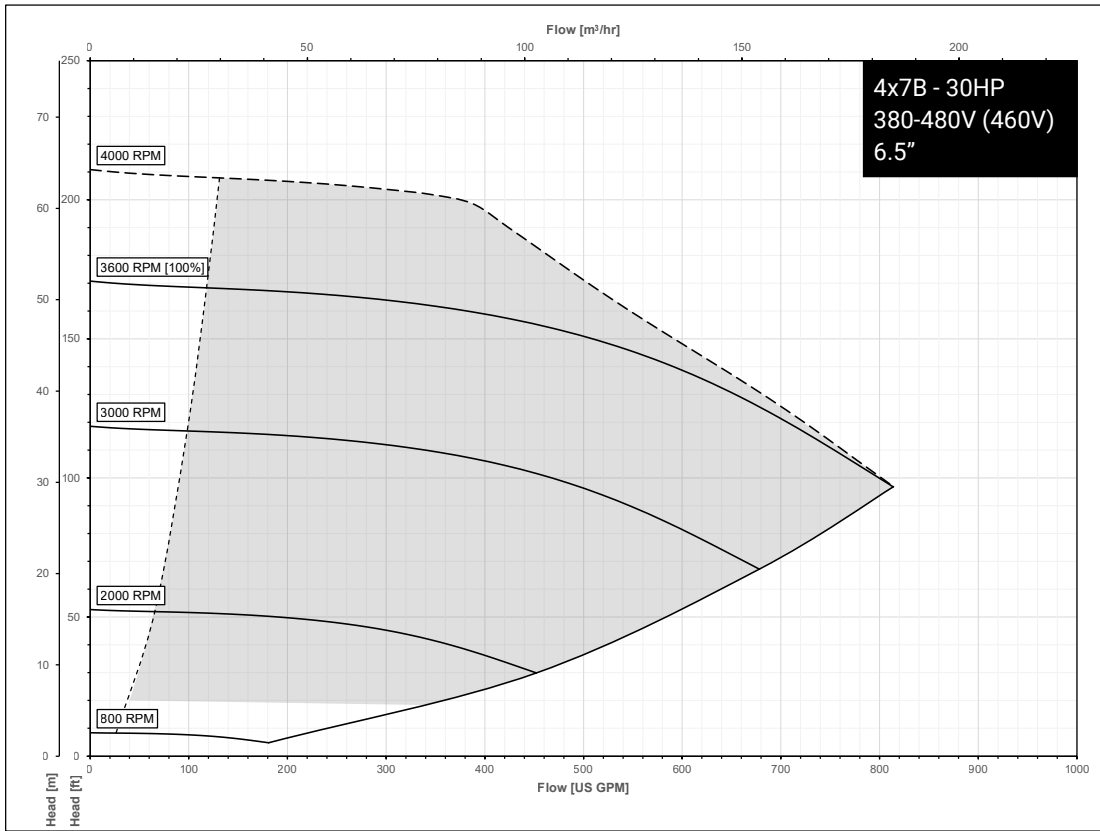

# Series e-80SCX performance curves for high speed models - 460V

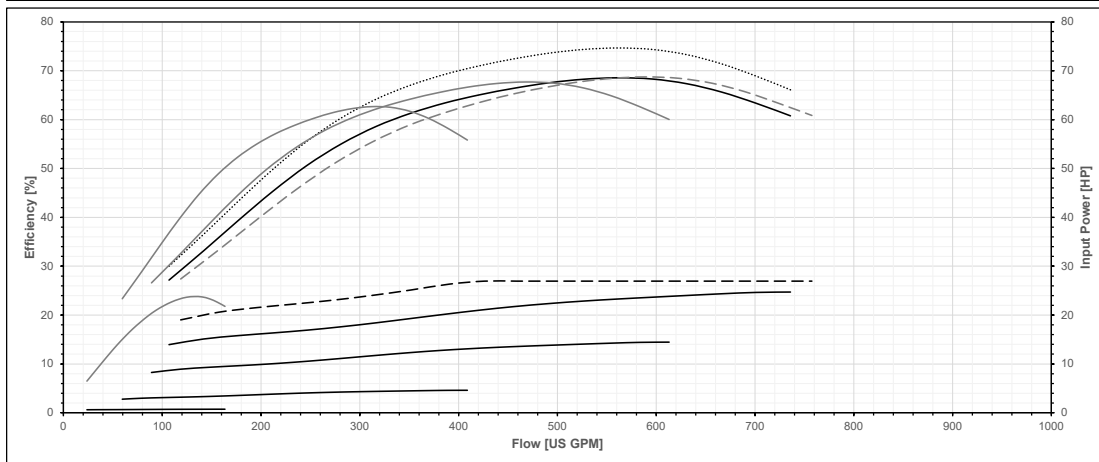
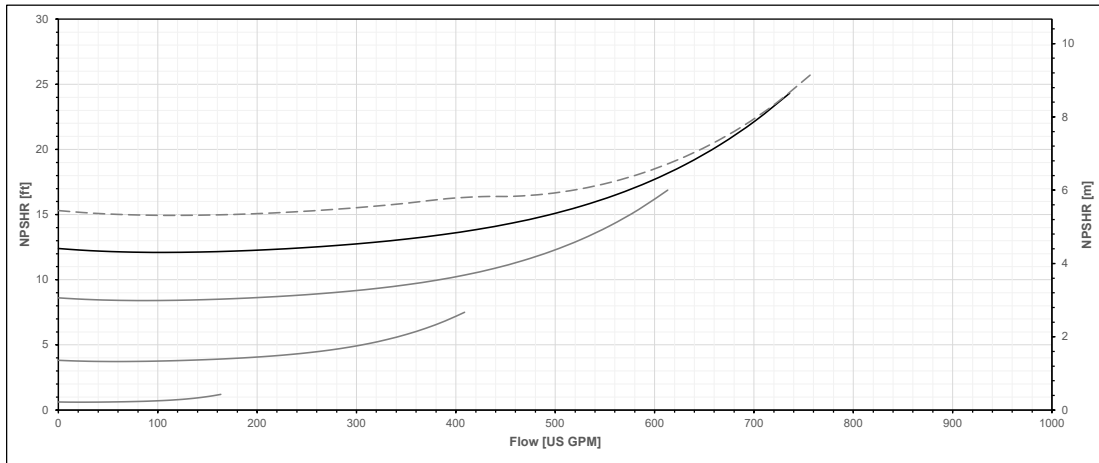
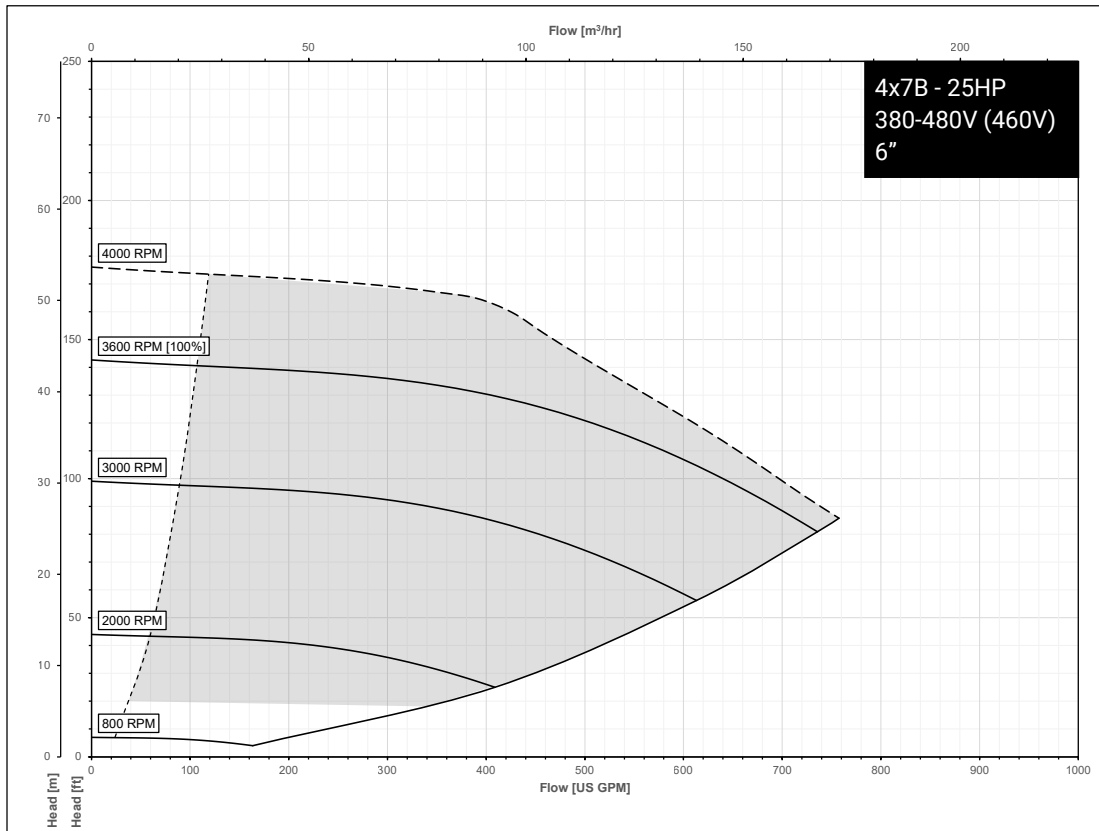

## Series e-80SCX performance curves for high speed models - 460V

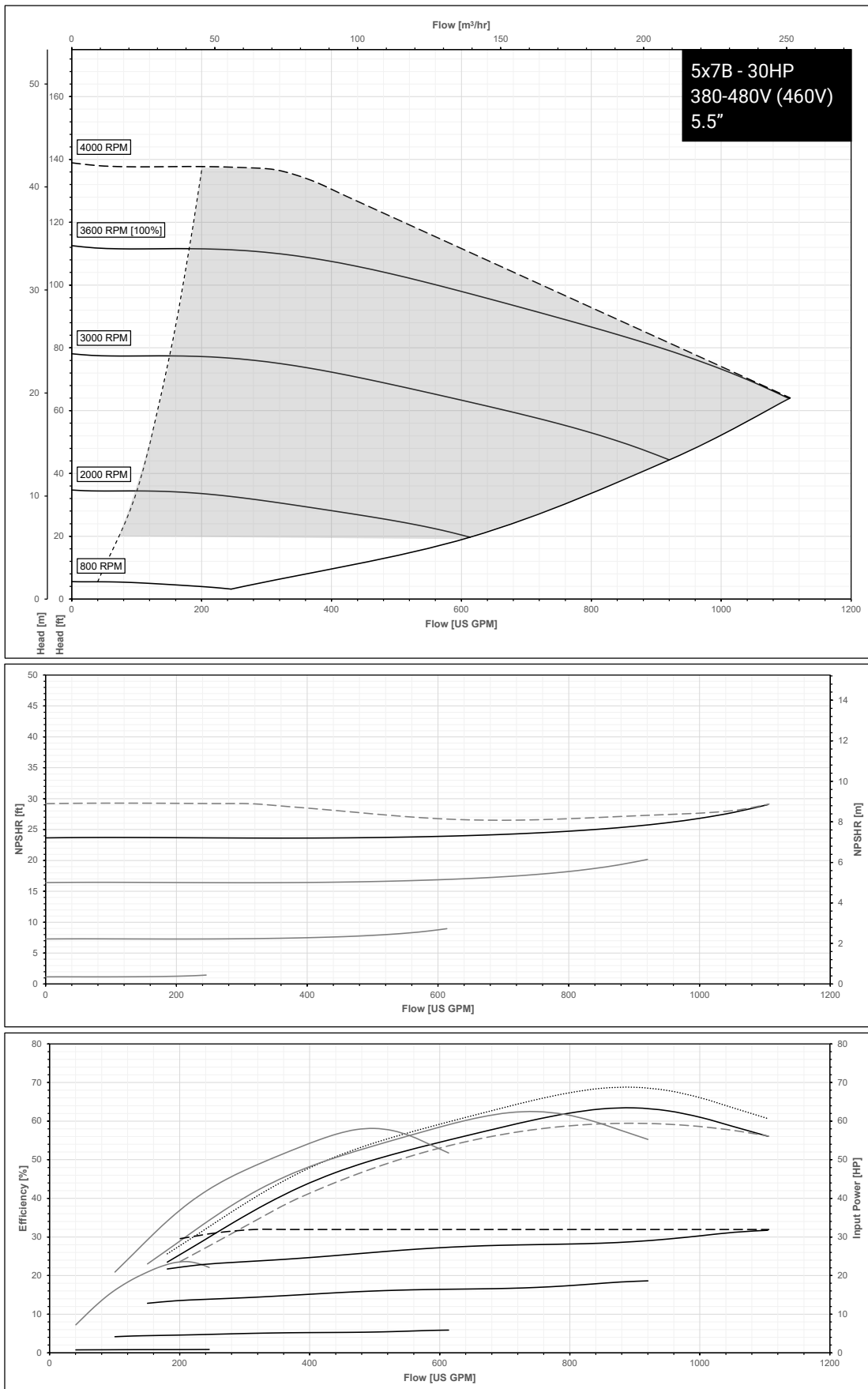

# Series e-80SCX performance curves for high speed models - 460V

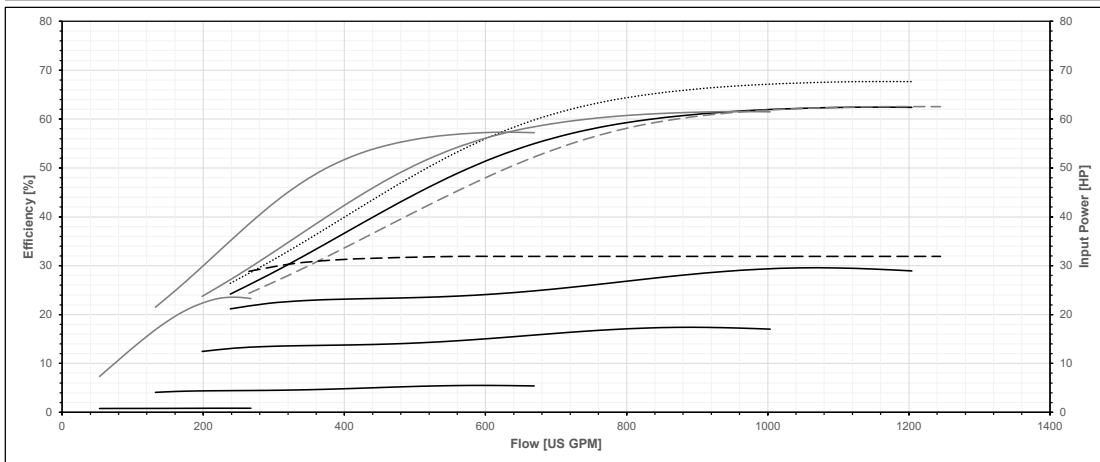
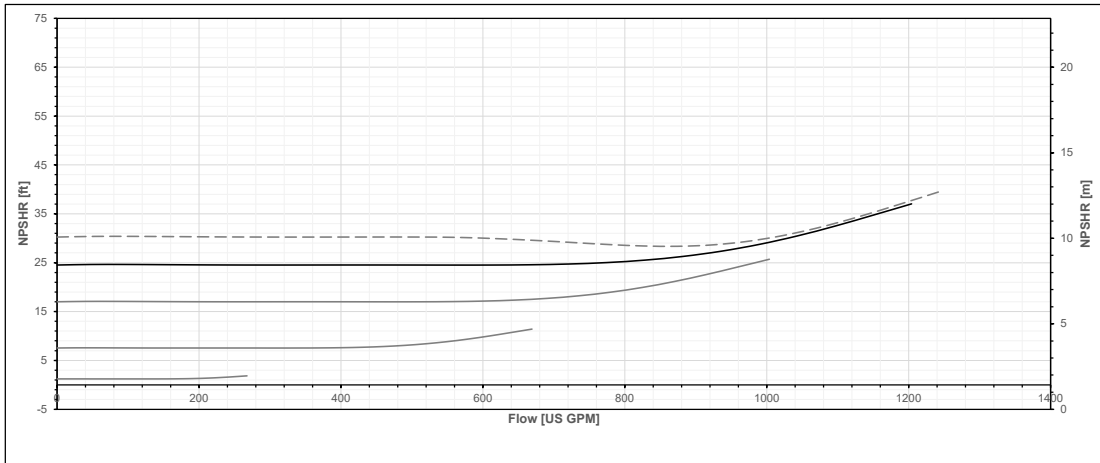
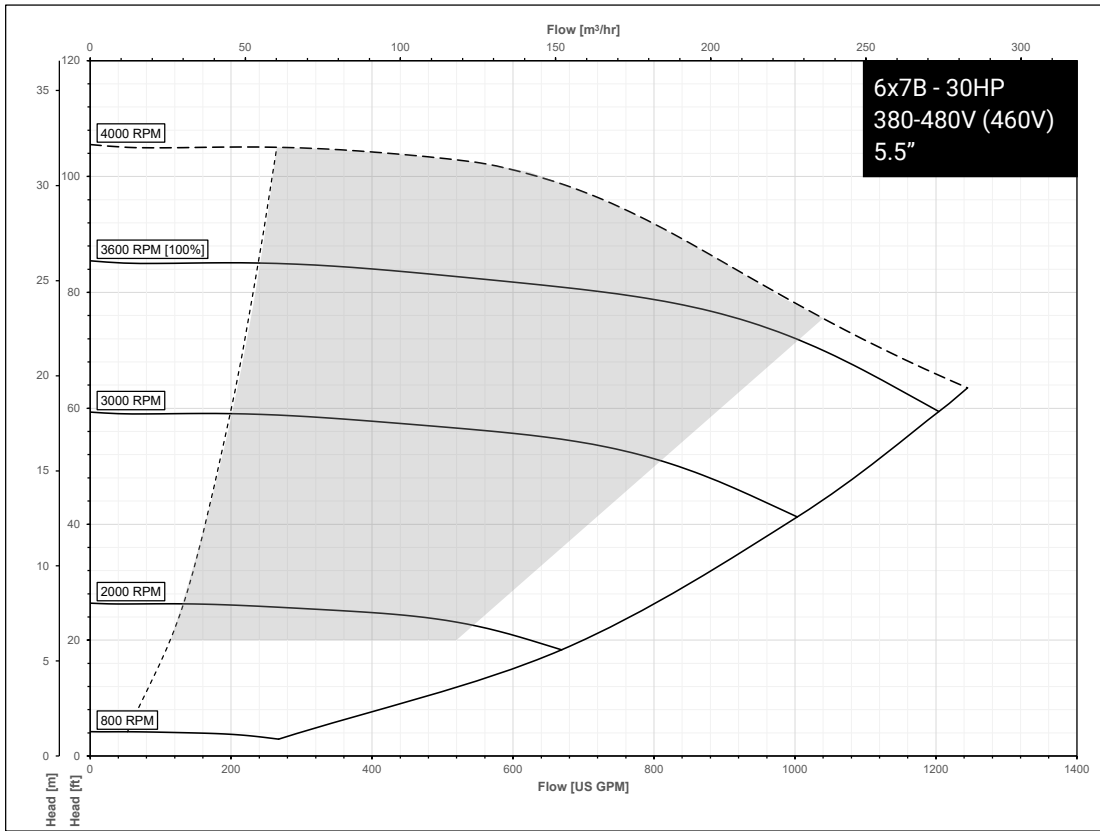

## Series e-80SCX performance curves for high speed models - 230V

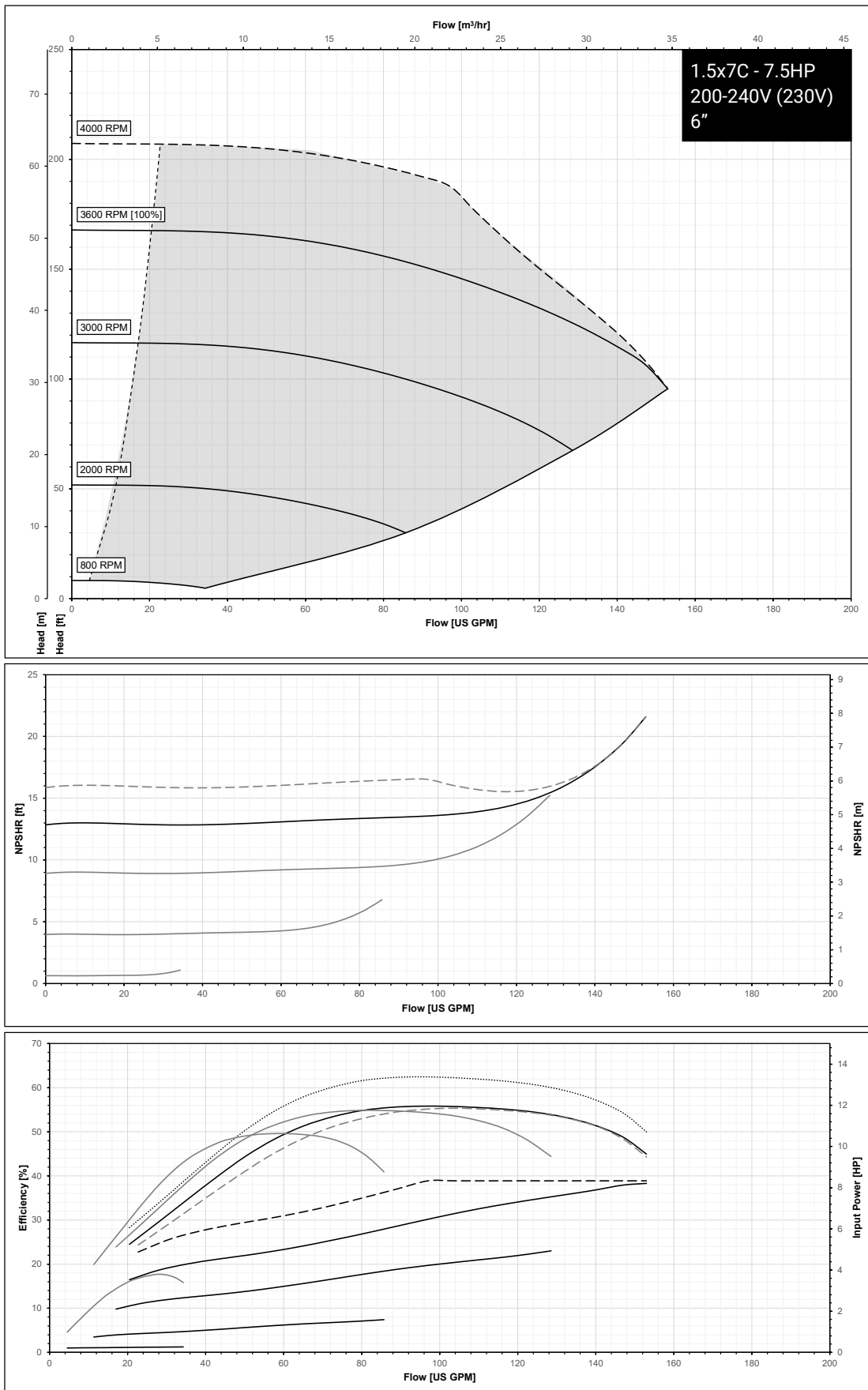

# Series e-80SCX performance curves for high speed models - 230V

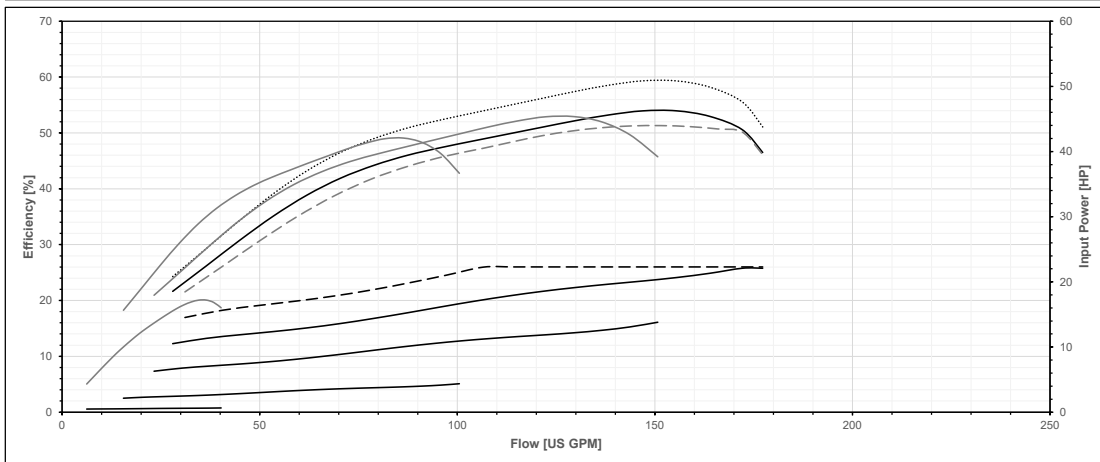
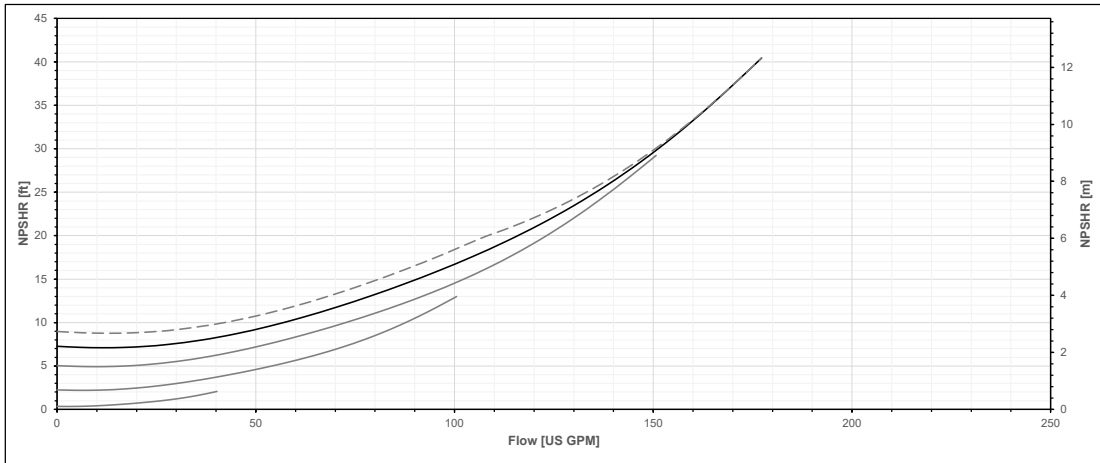
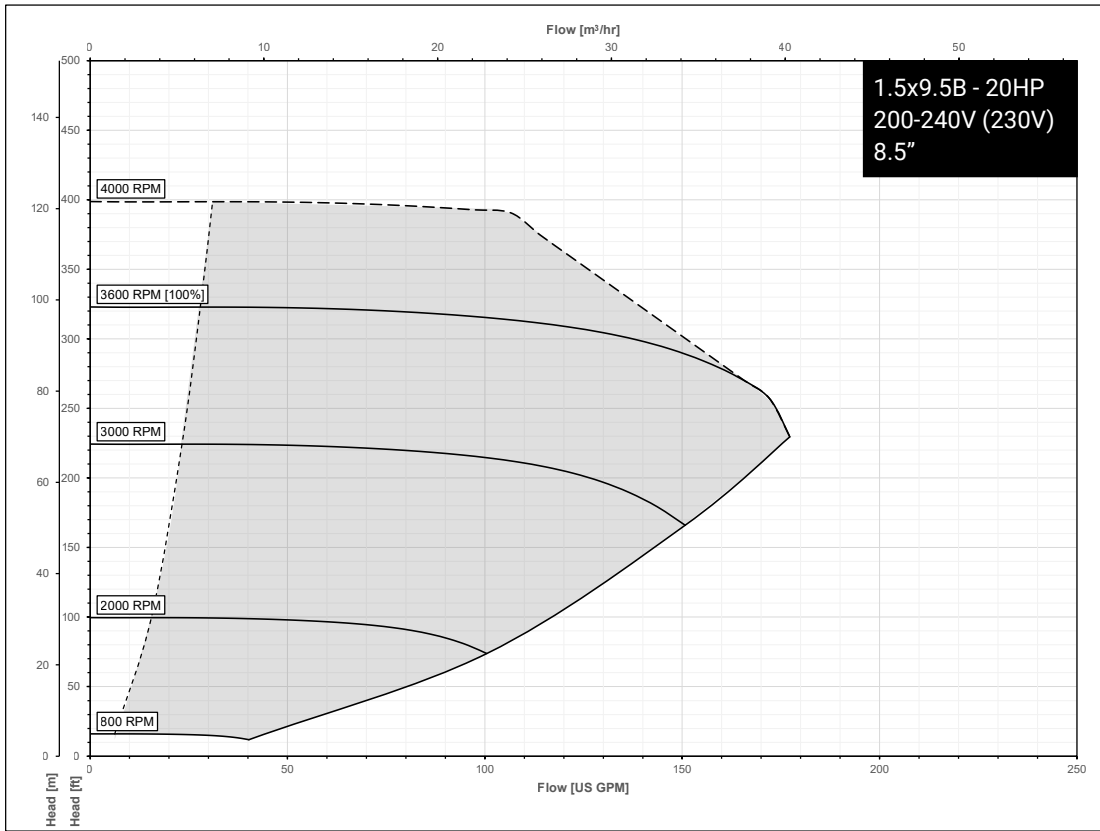

# Series e-80SCX performance curves for high speed models - 230V

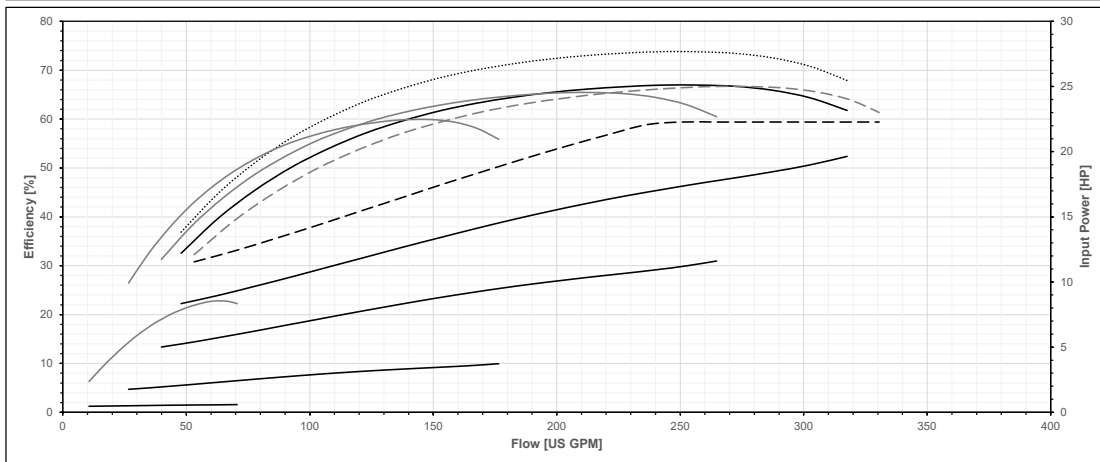
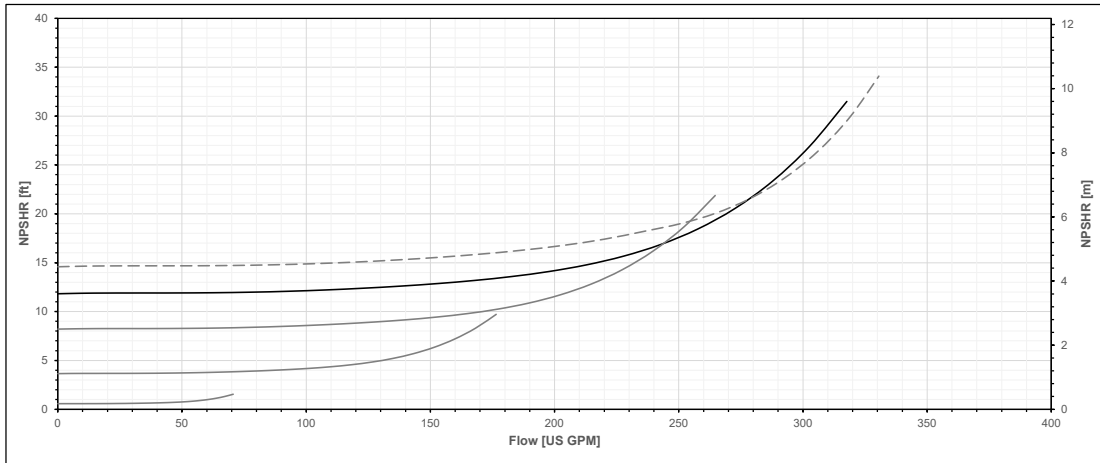
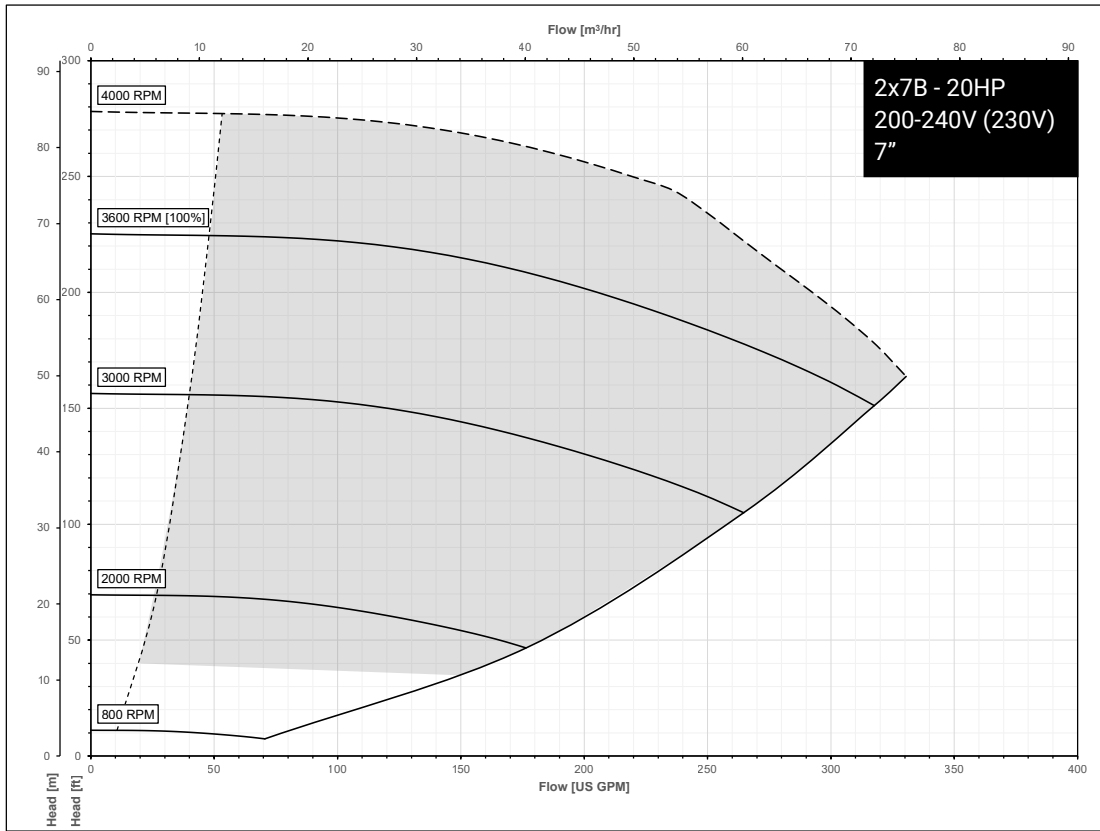

# Series e-80SCX performance curves for high speed models - 230V

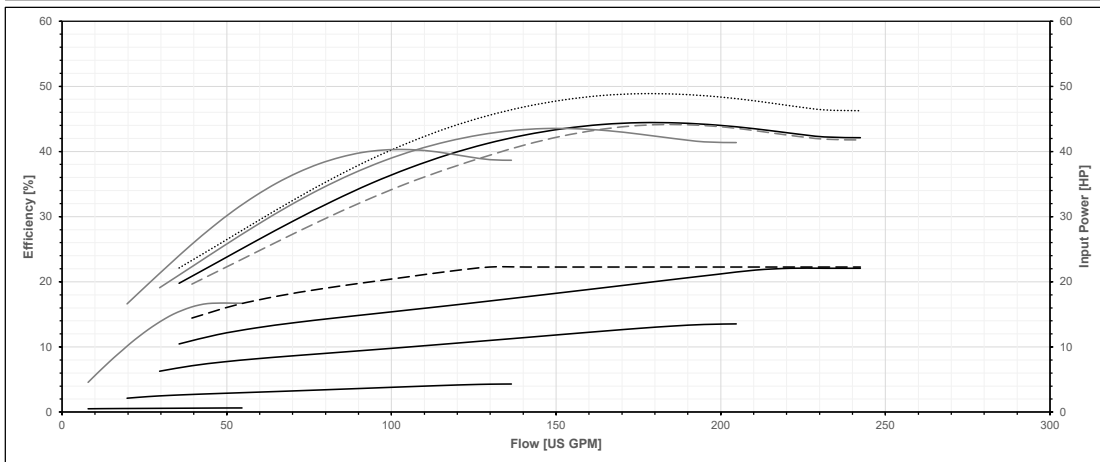
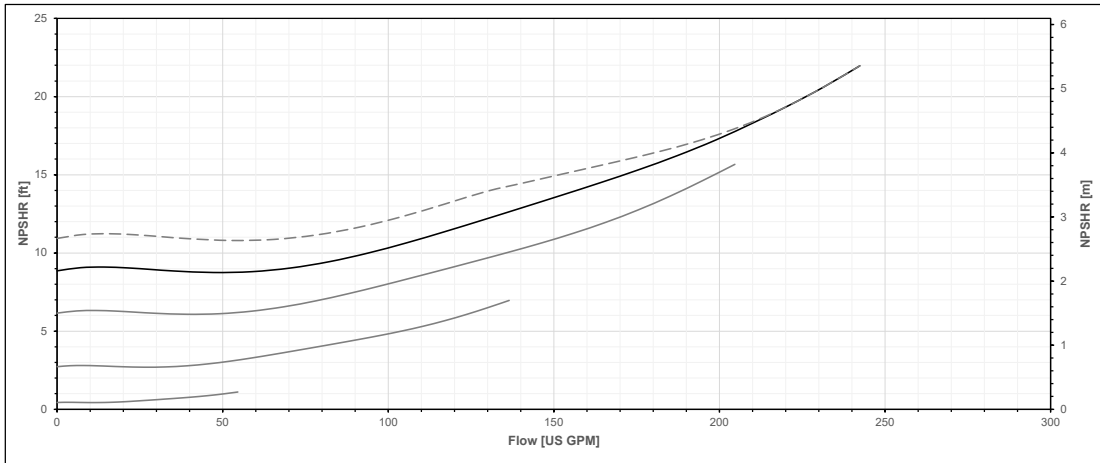
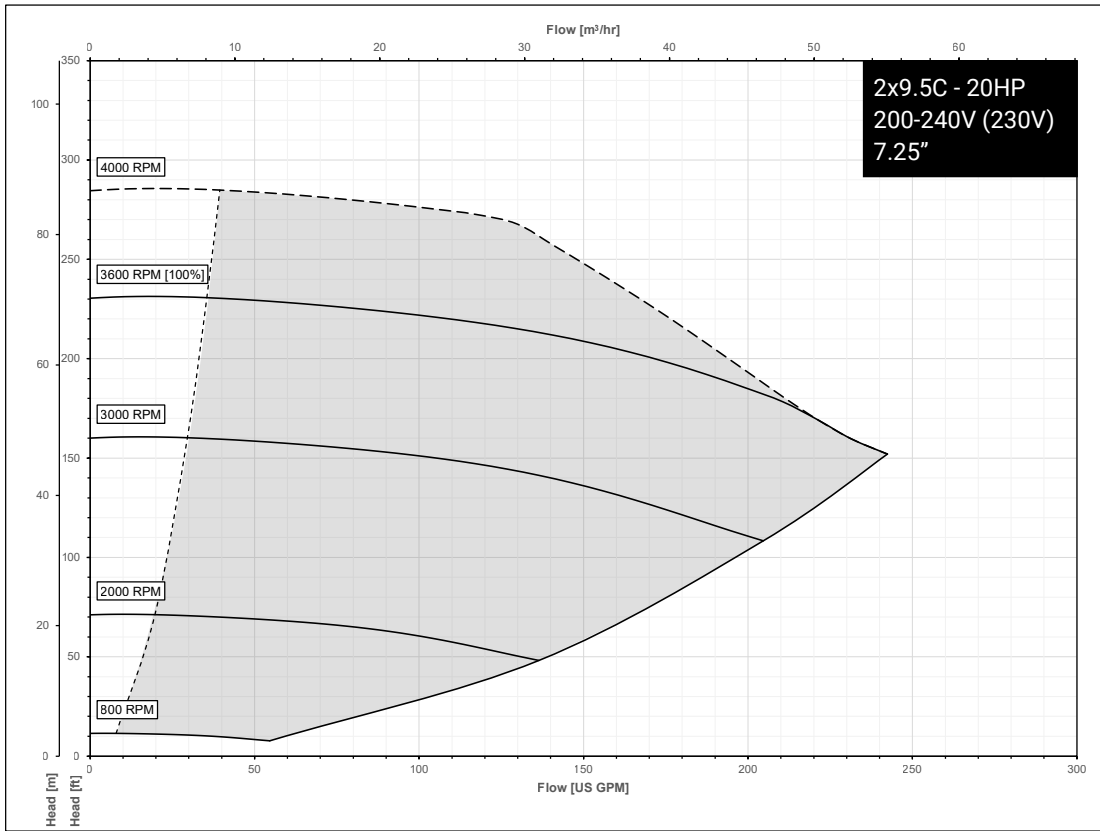

# Series e-80SCX performance curves for high speed models - 230V

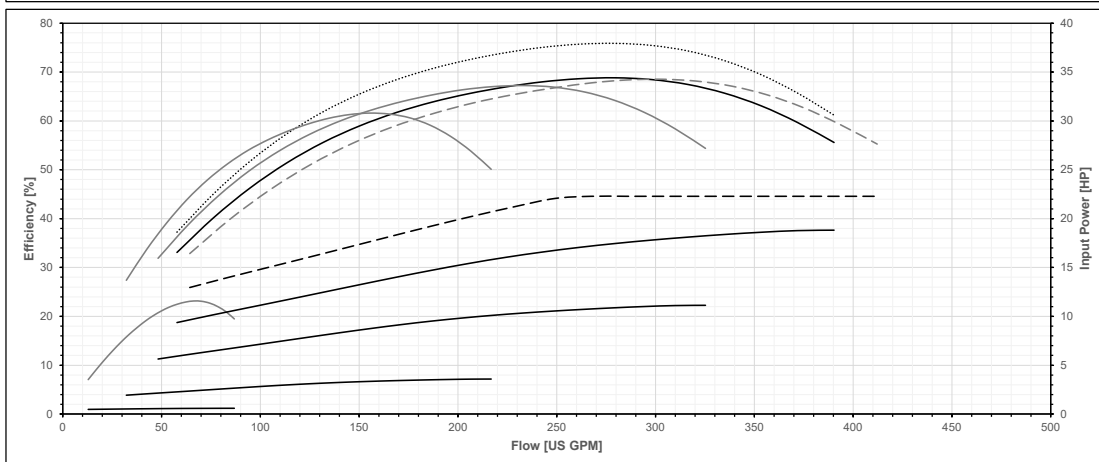
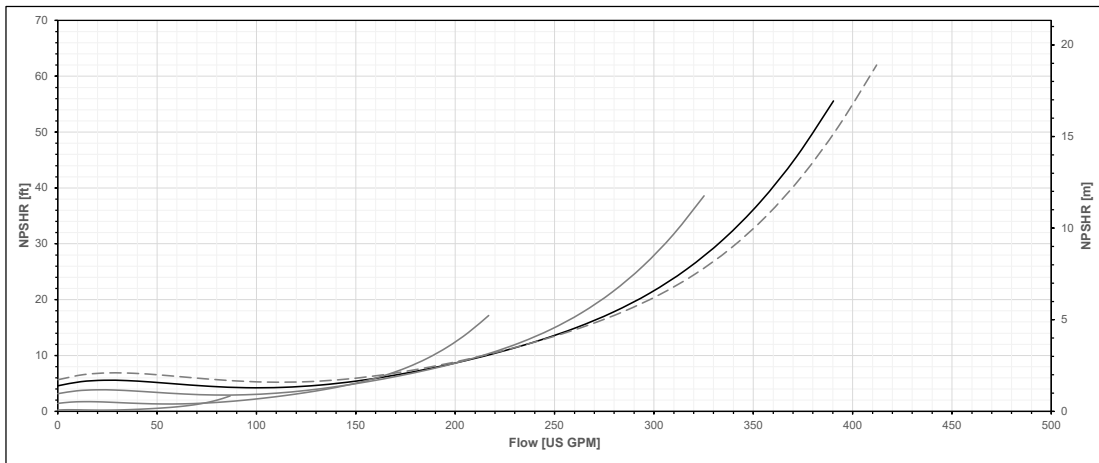
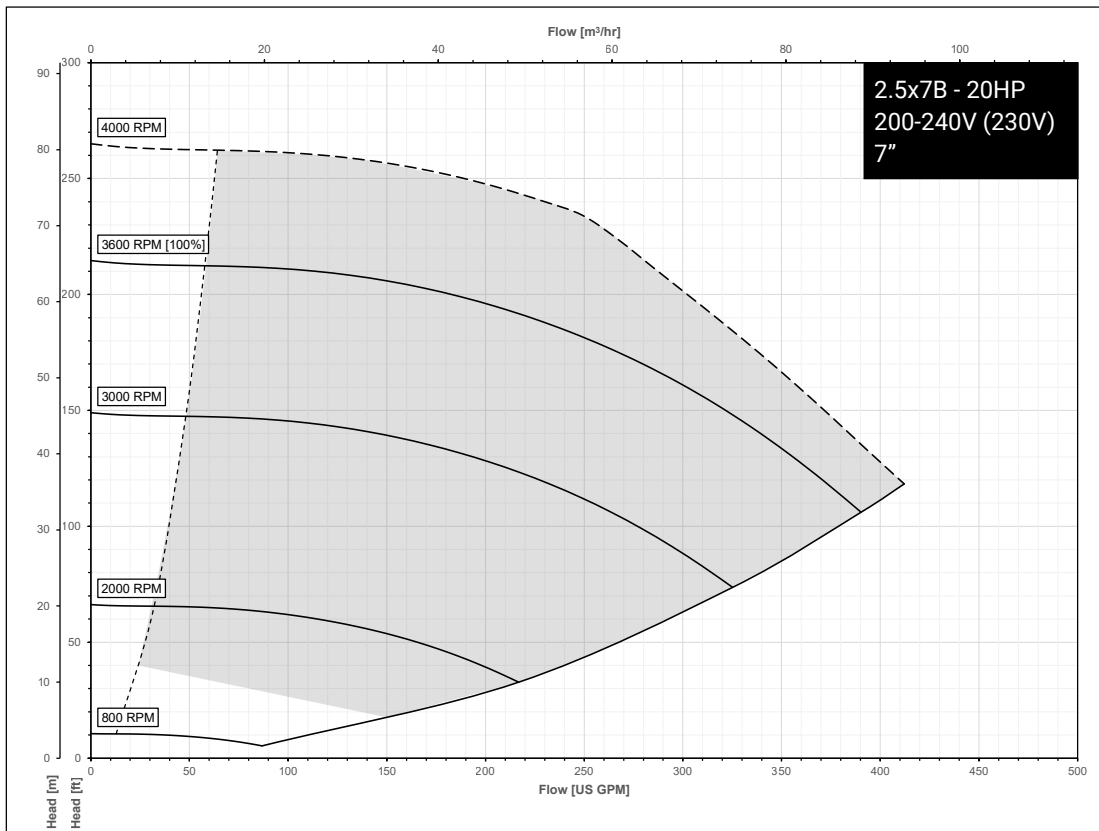

# Series e-80SCX performance curves for high speed models - 230V

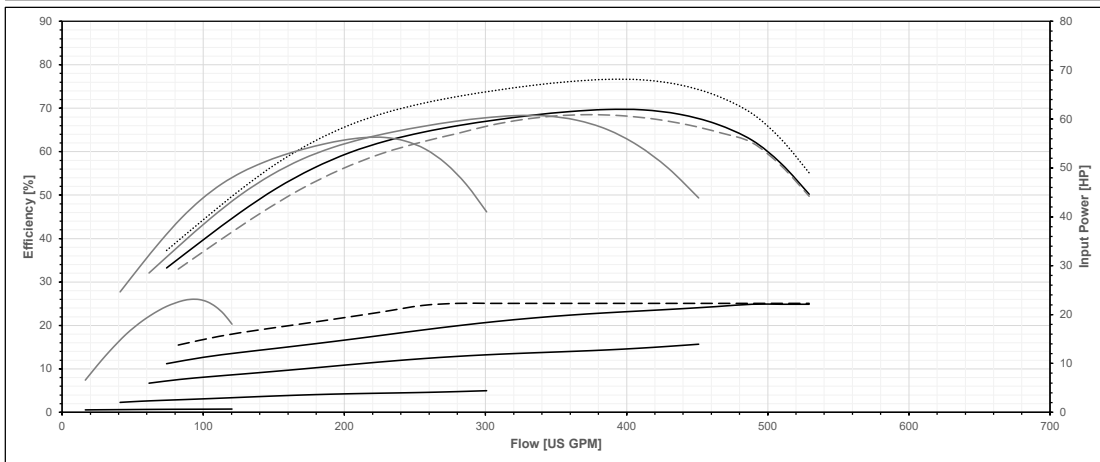
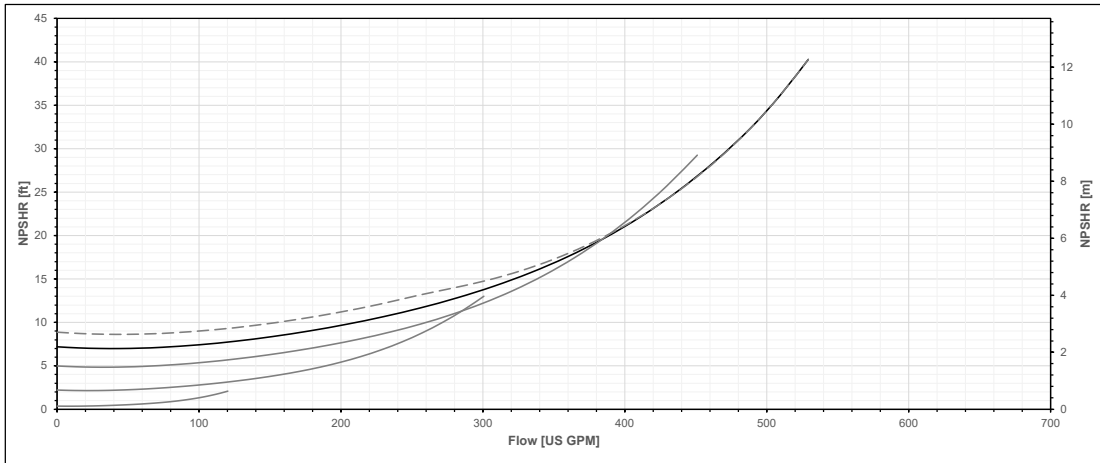
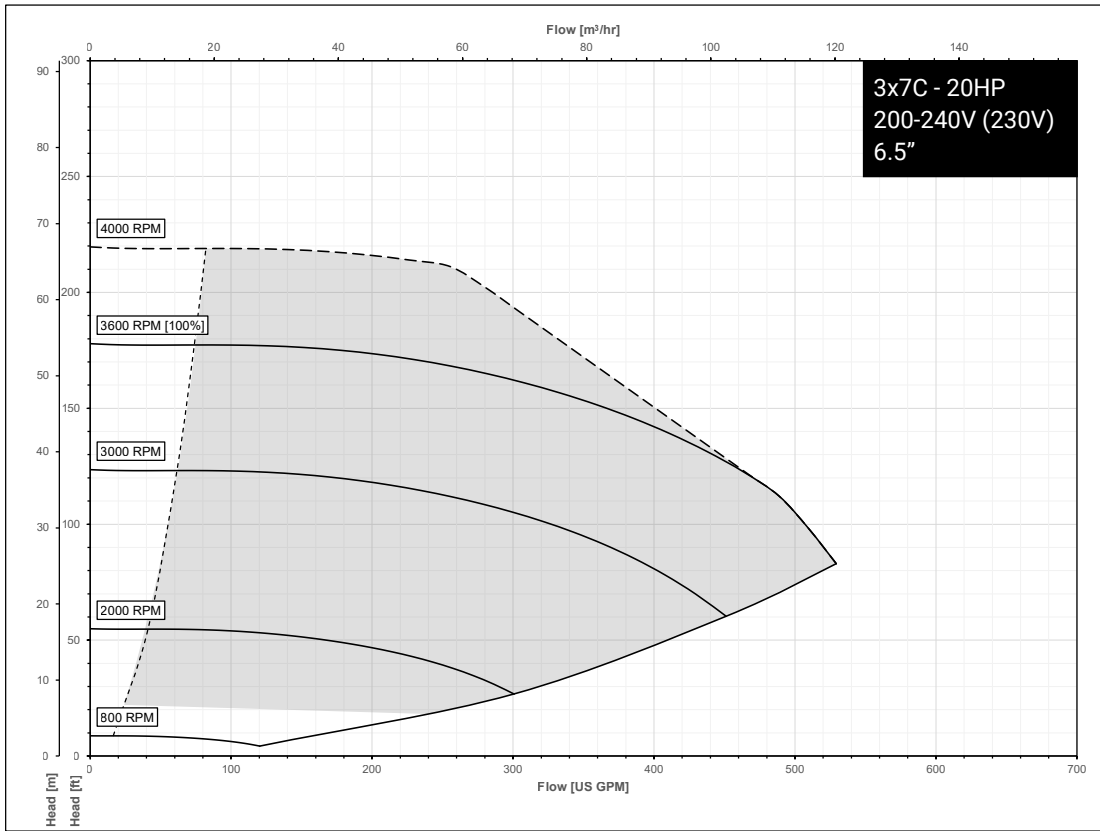

# Series e-80SCX performance curves for high speed models - 460V

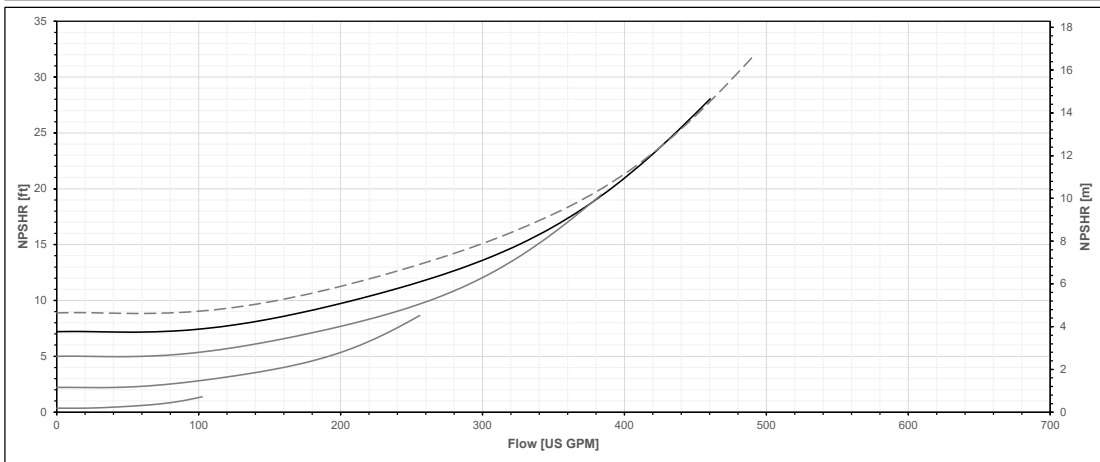
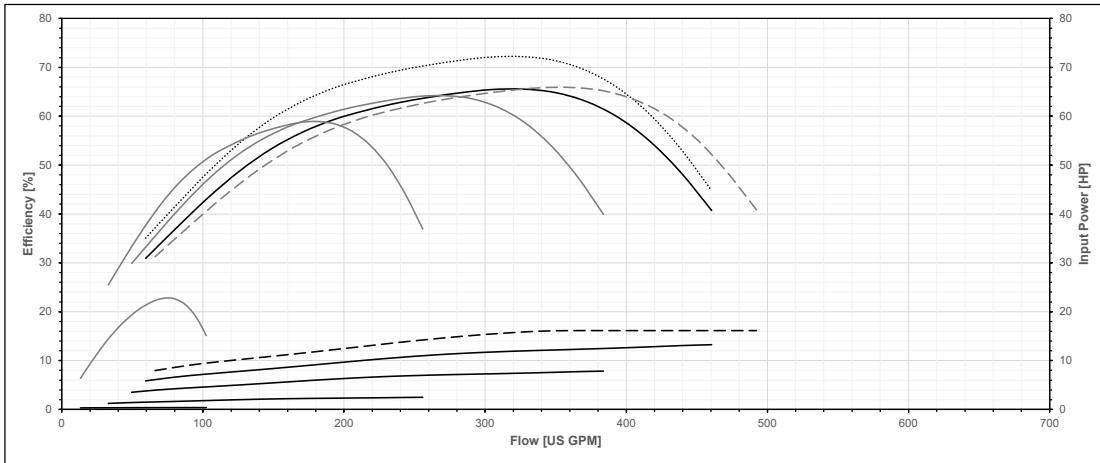
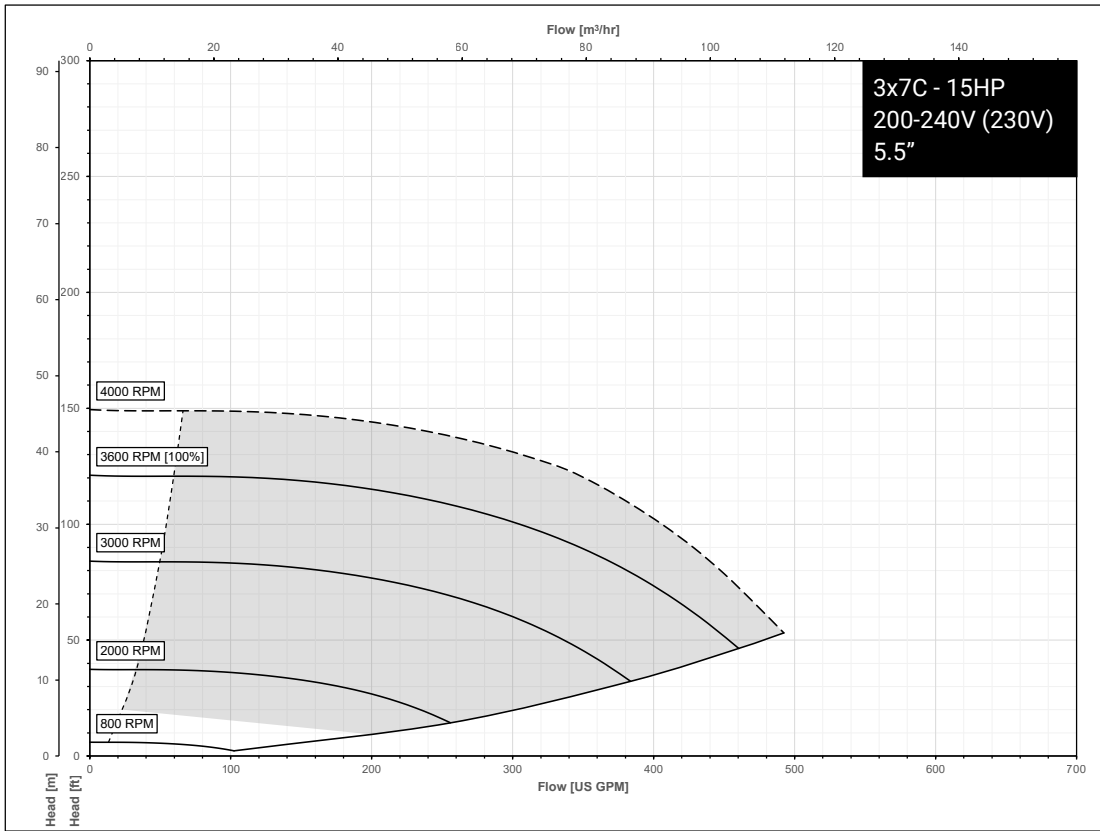

# Series e-80SCX performance curves for high speed models - 230V

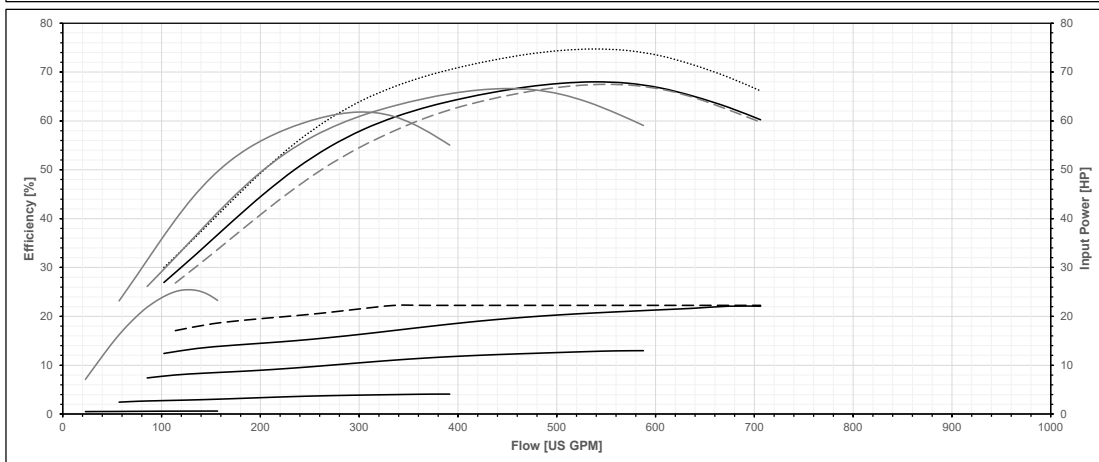
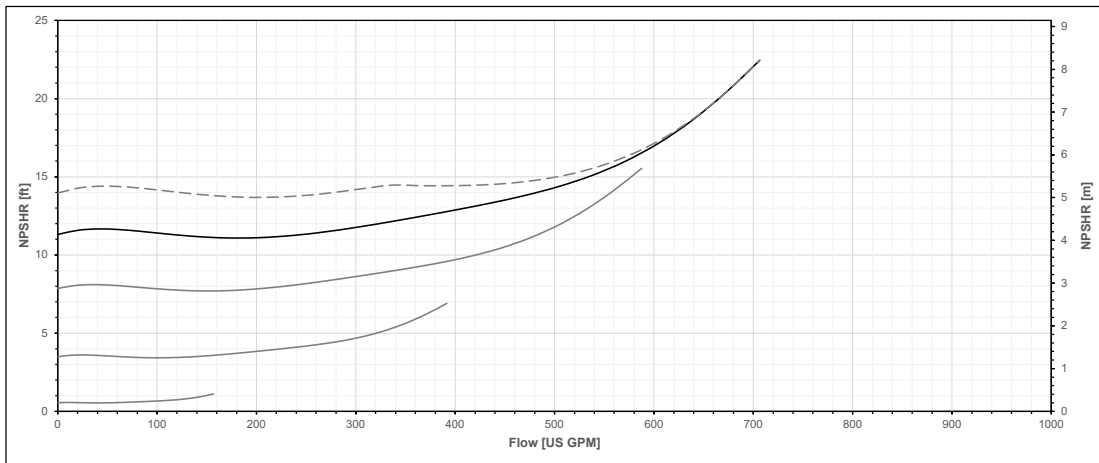
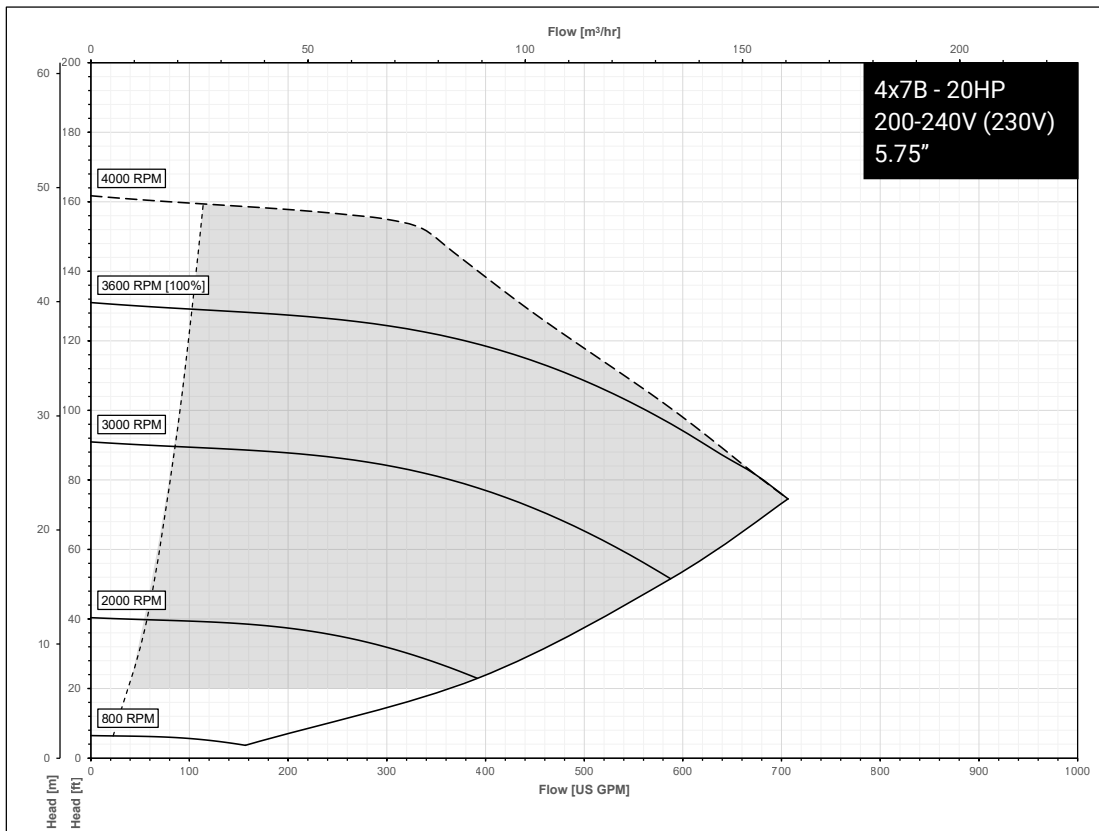

# Series e-80SCX performance curves for high speed models - 230V

Note: size not suitable for sensorless operation

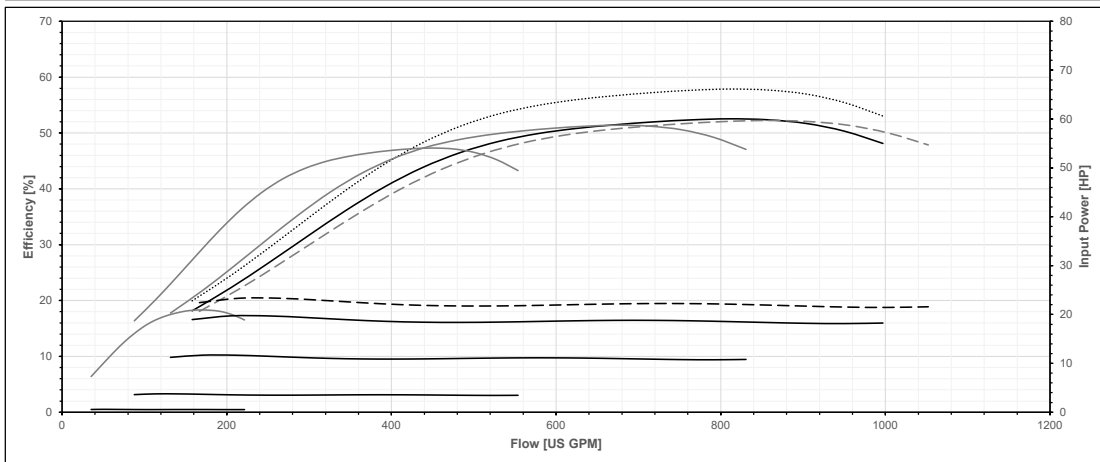
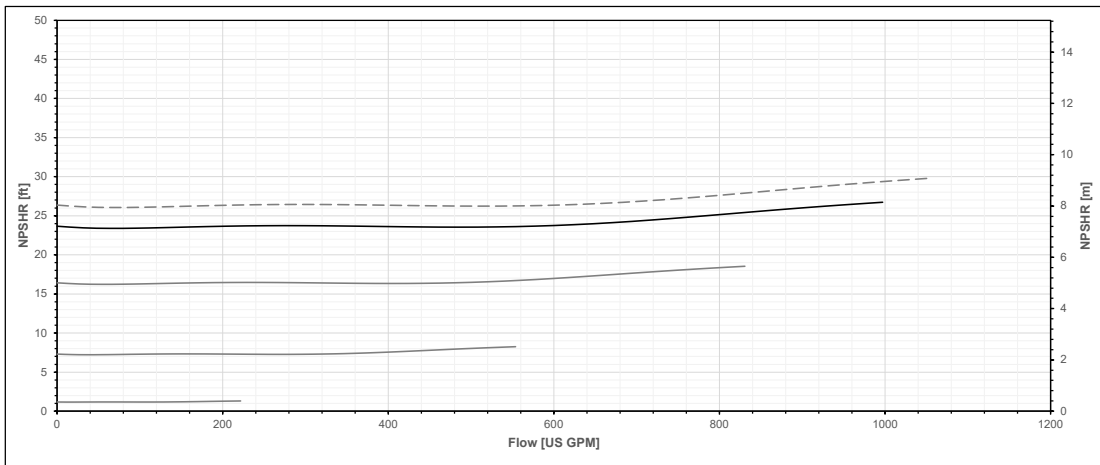
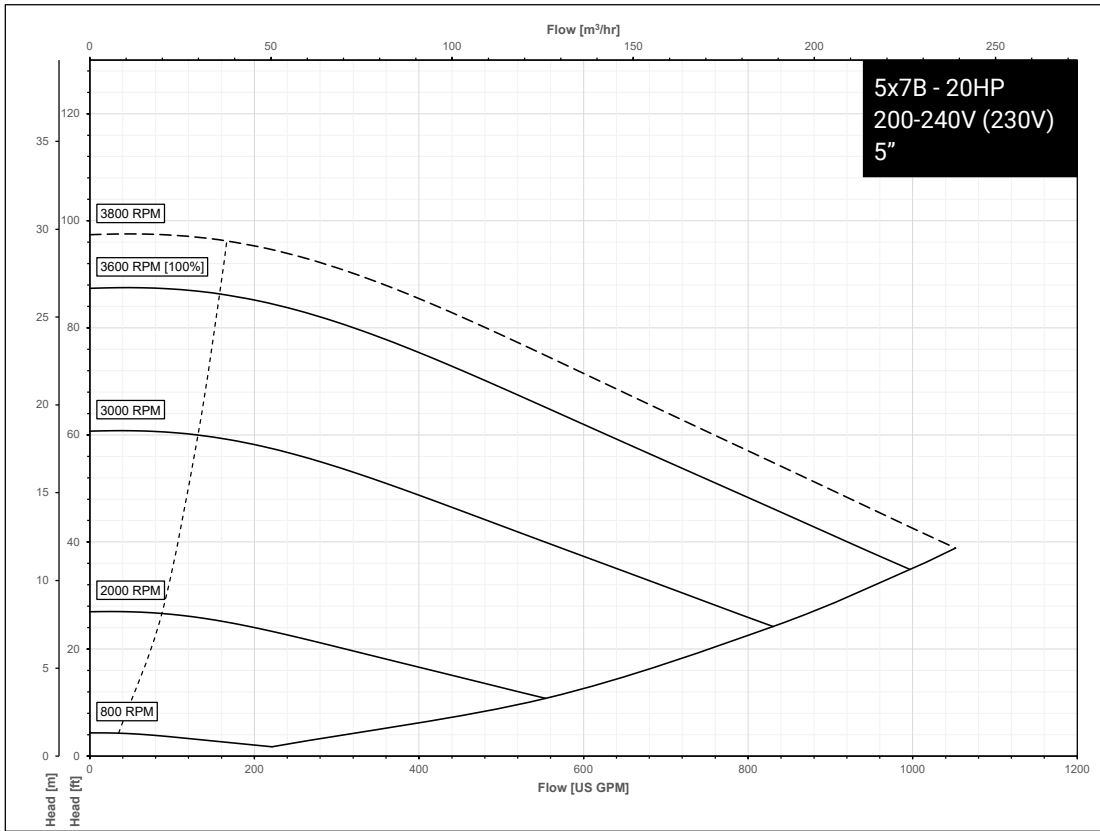

# Series e-80SCX performance curves for low speed models

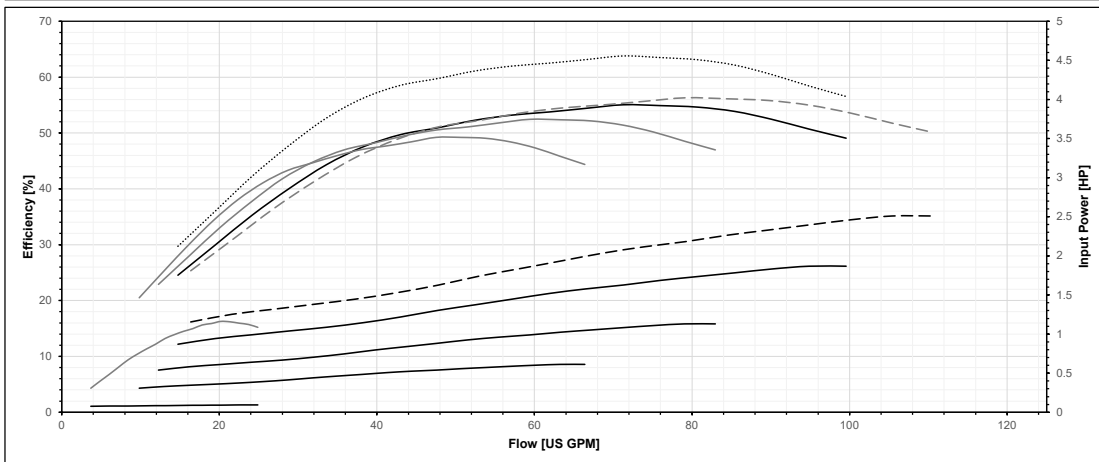
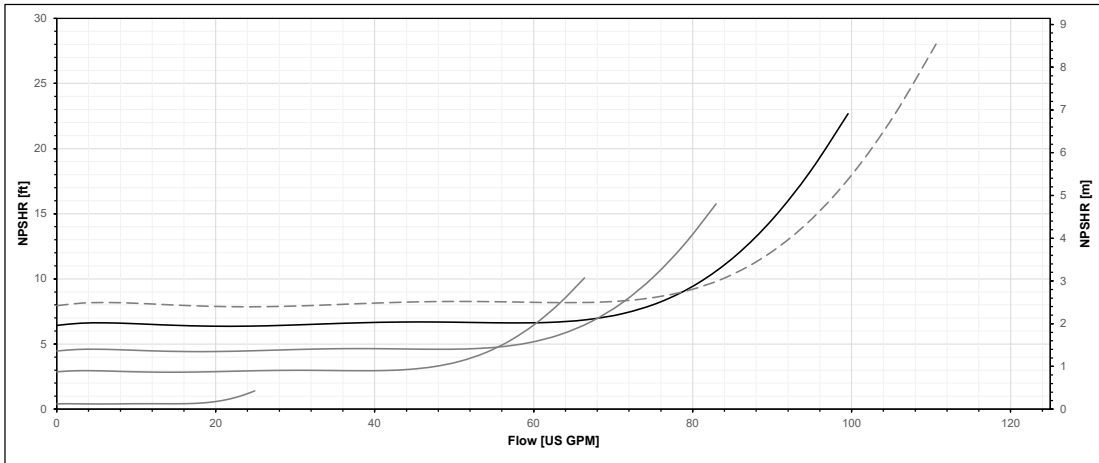
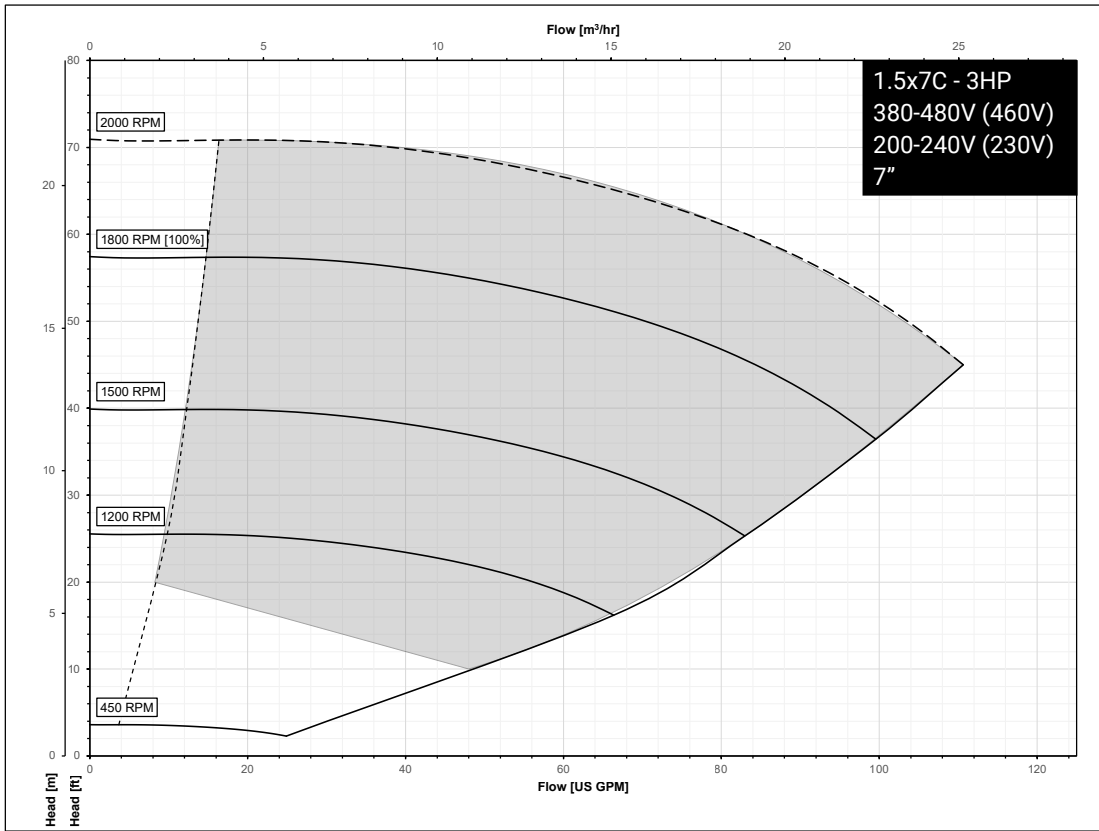

# Series e-80SCX performance curves for low speed models

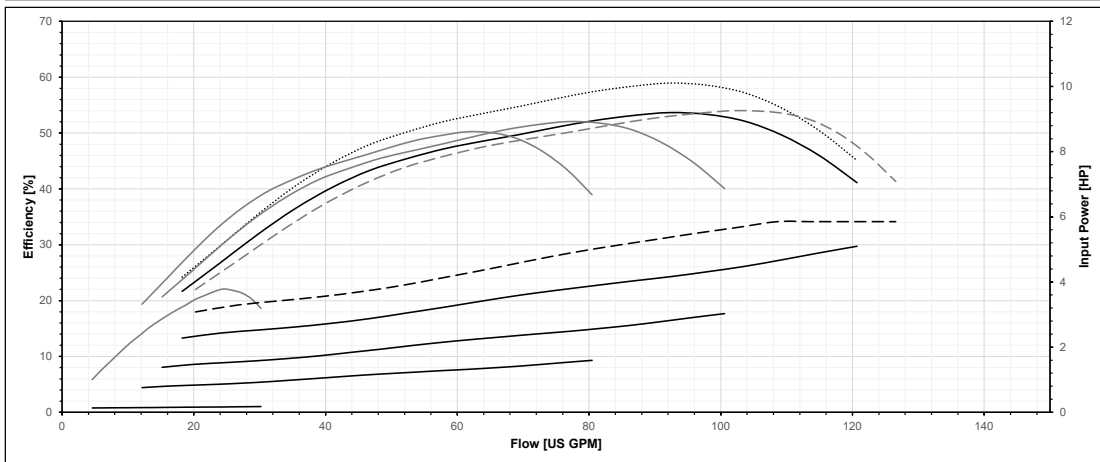
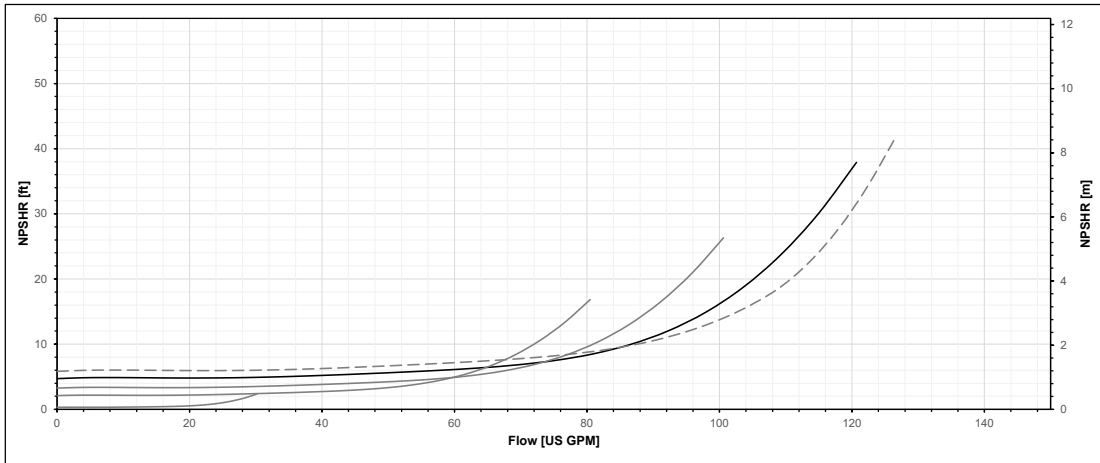
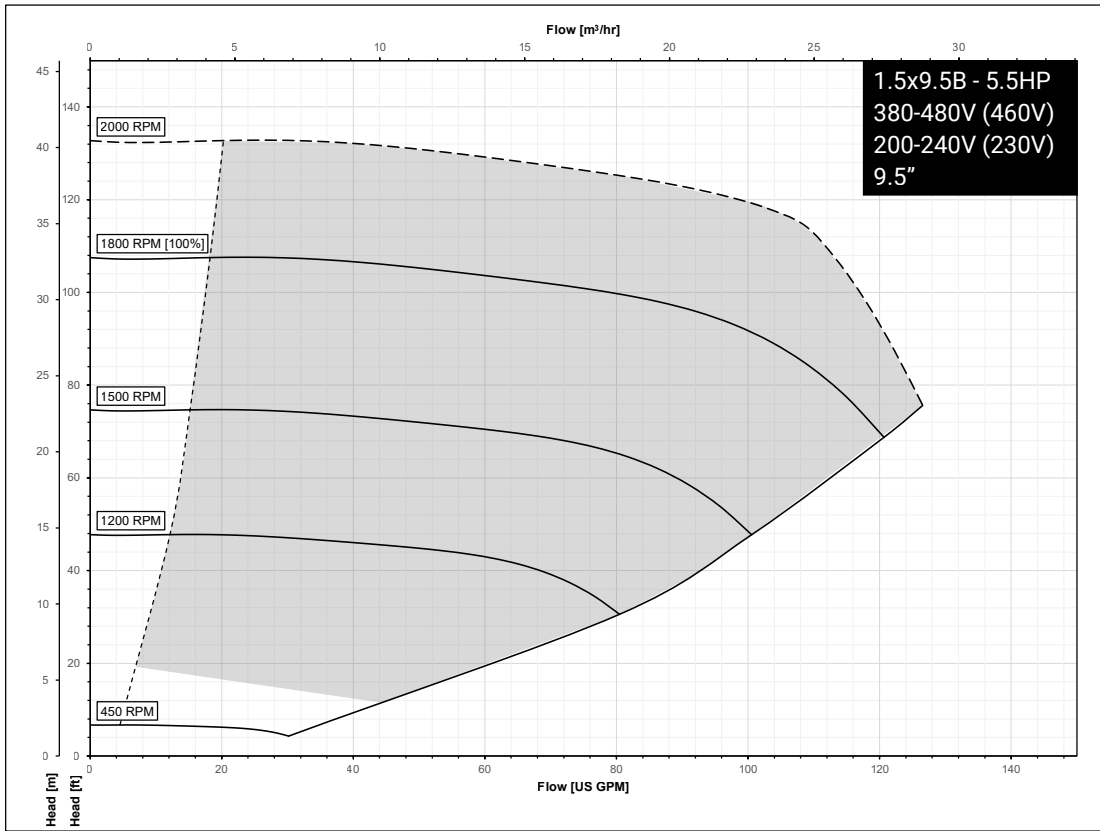

# Series e-80SCX performance curves for low speed models

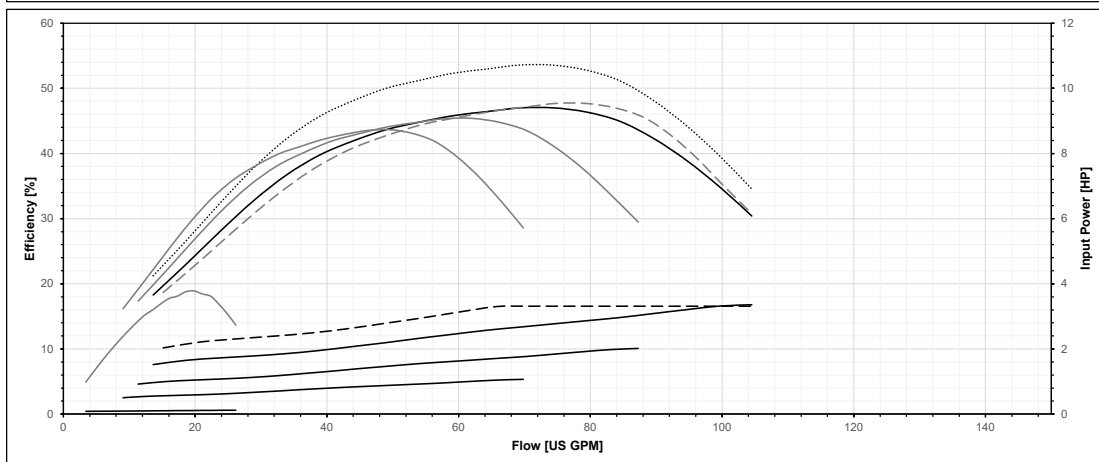
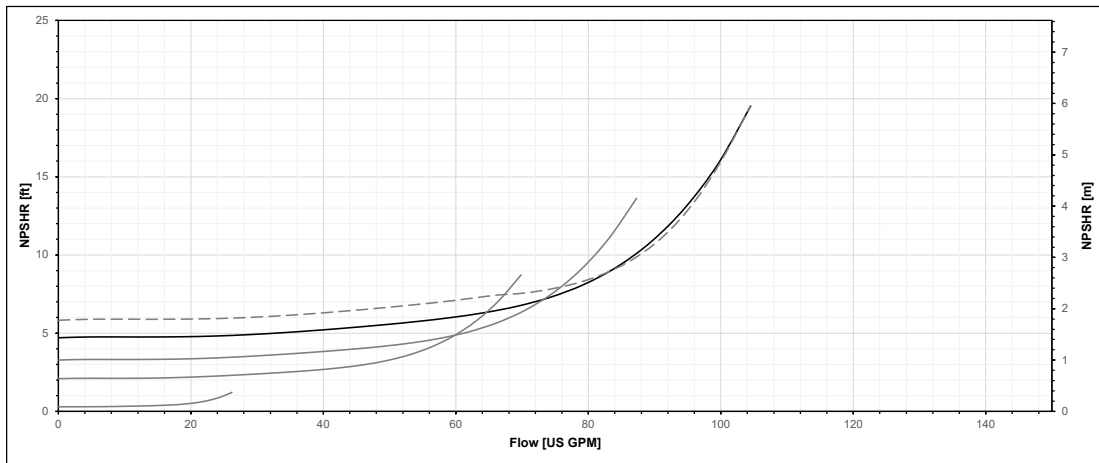
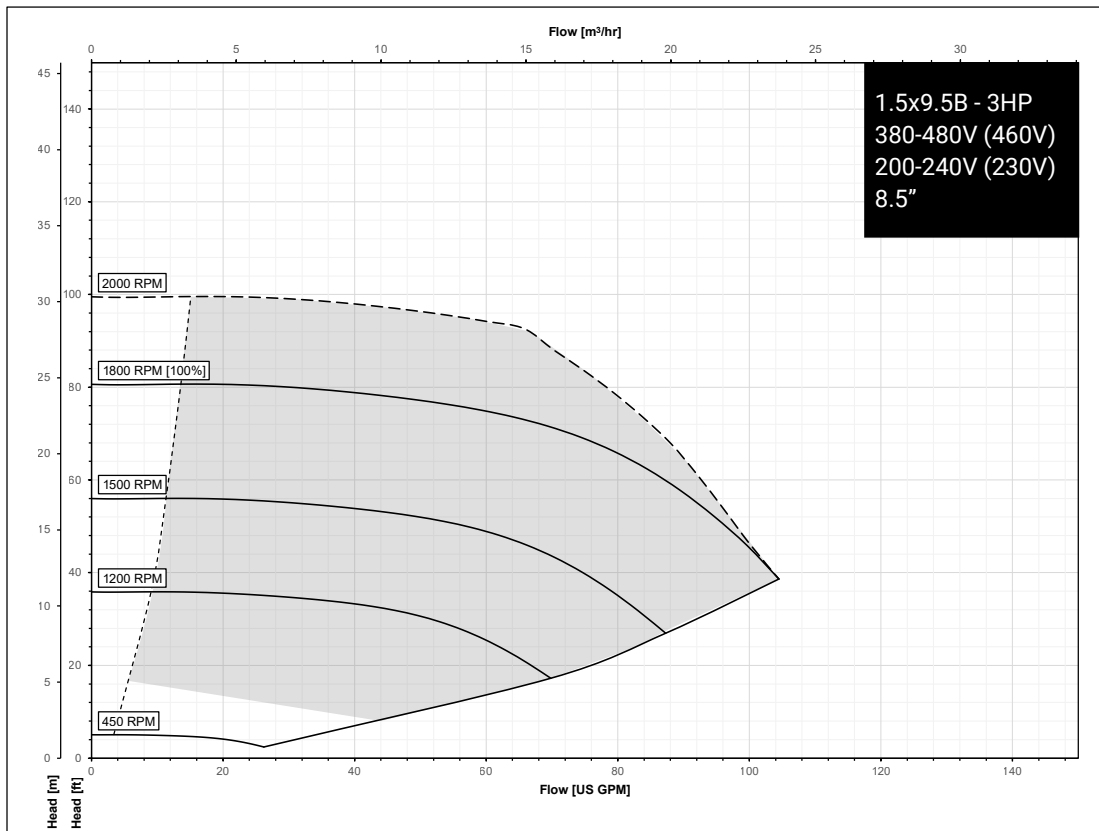

# Series e-80SCX performance curves for low speed models

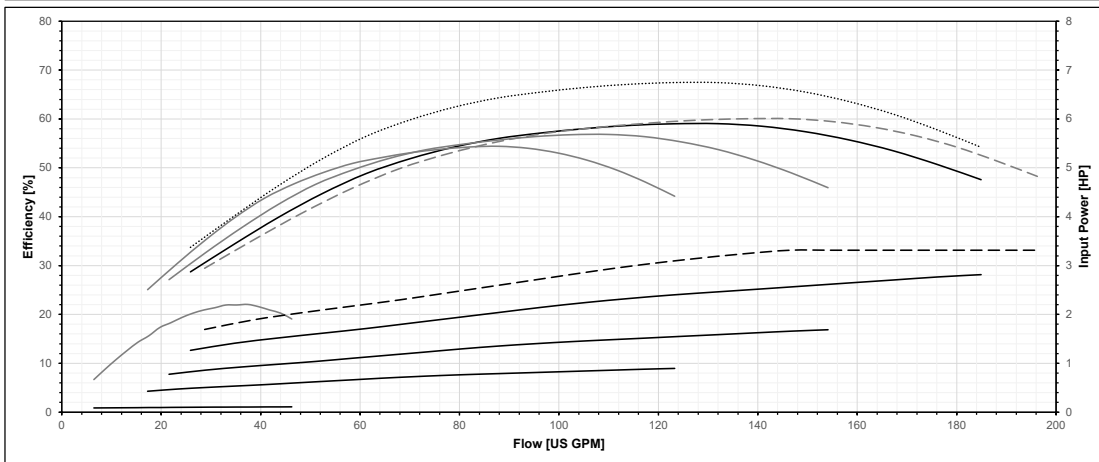
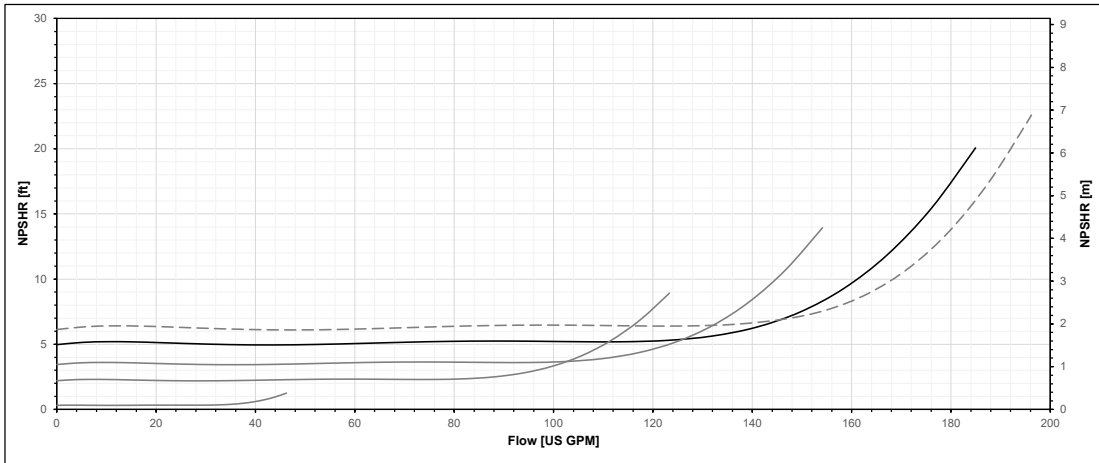
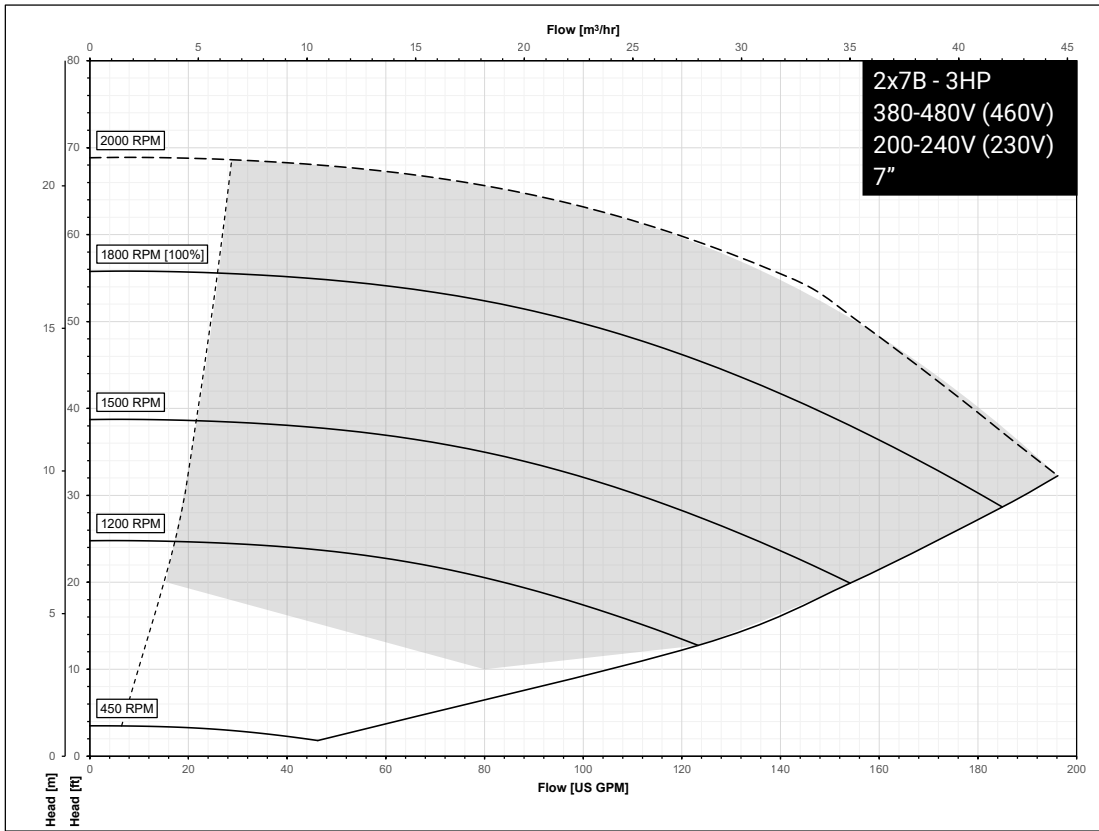

# Series e-80SCX performance curves for low speed models

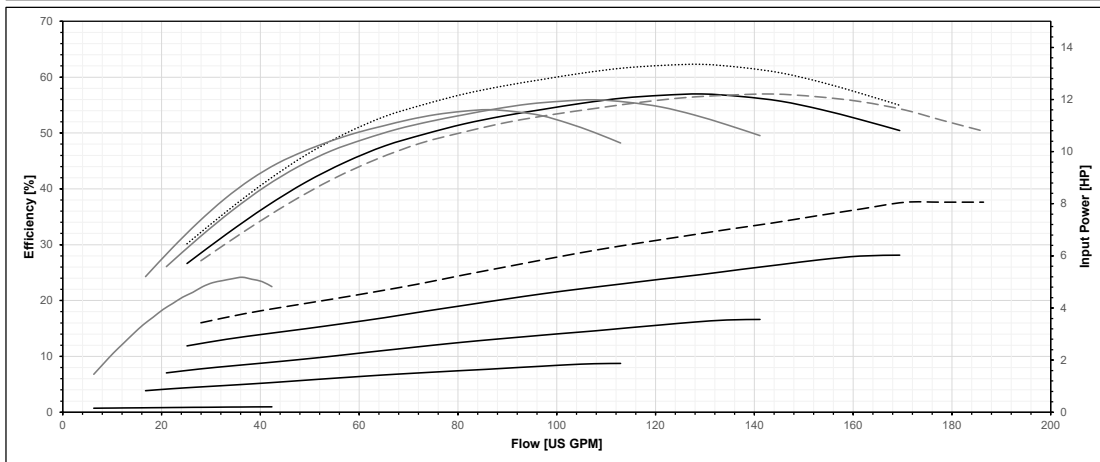
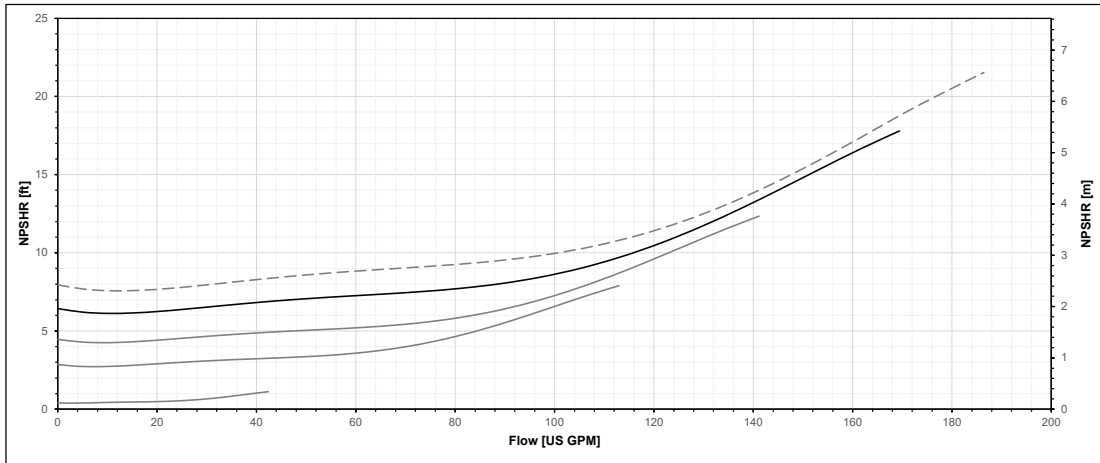
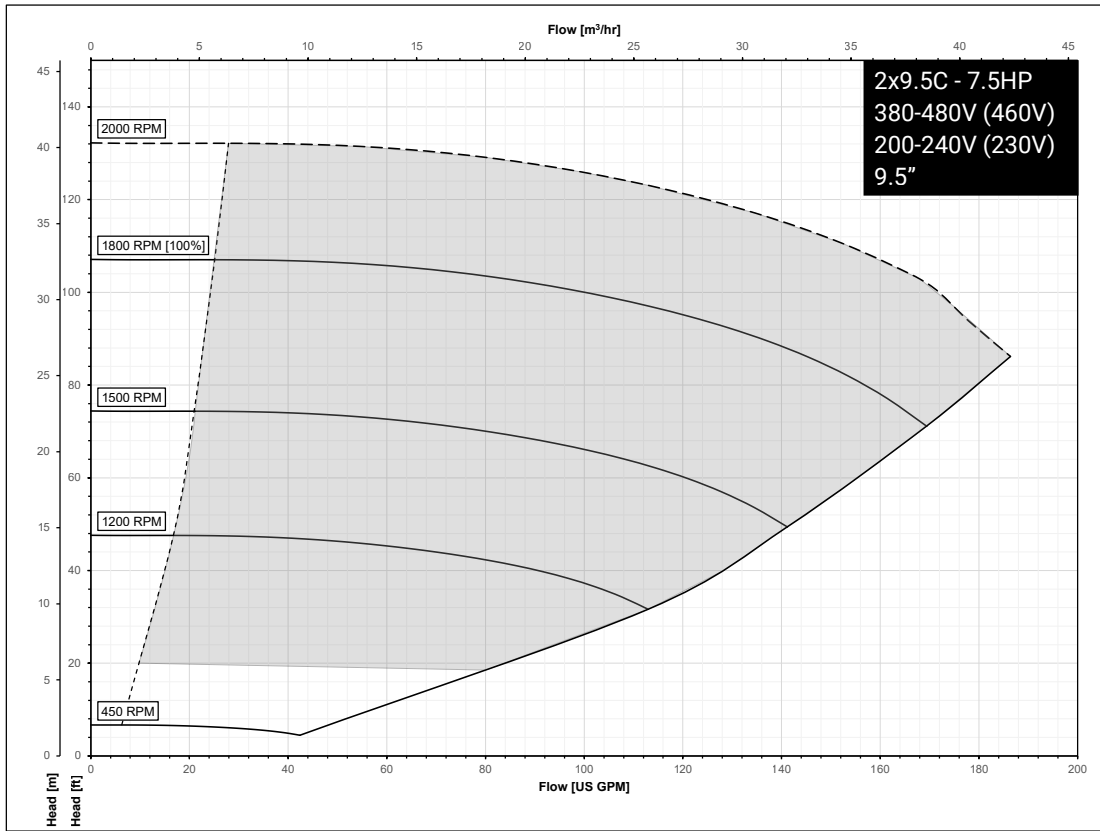

# Series e-80SCX performance curves for low speed models

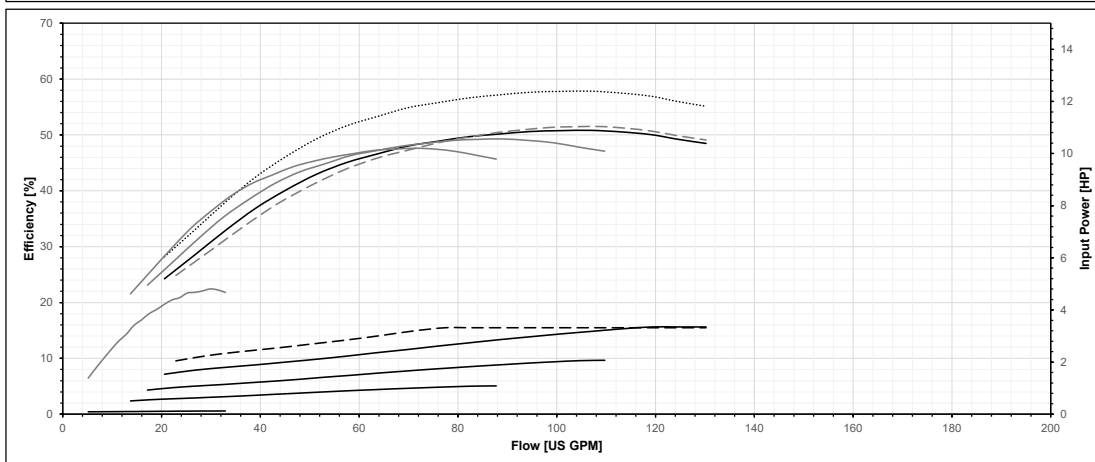
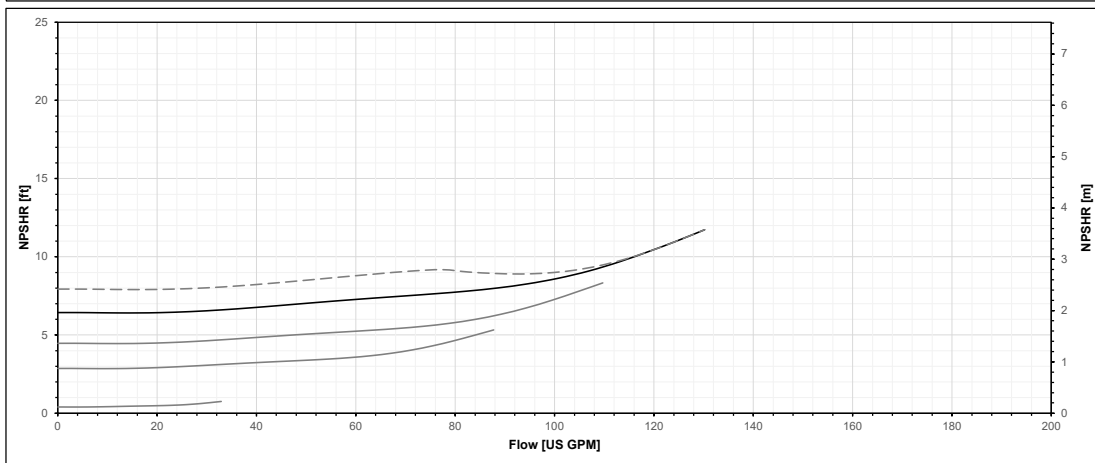
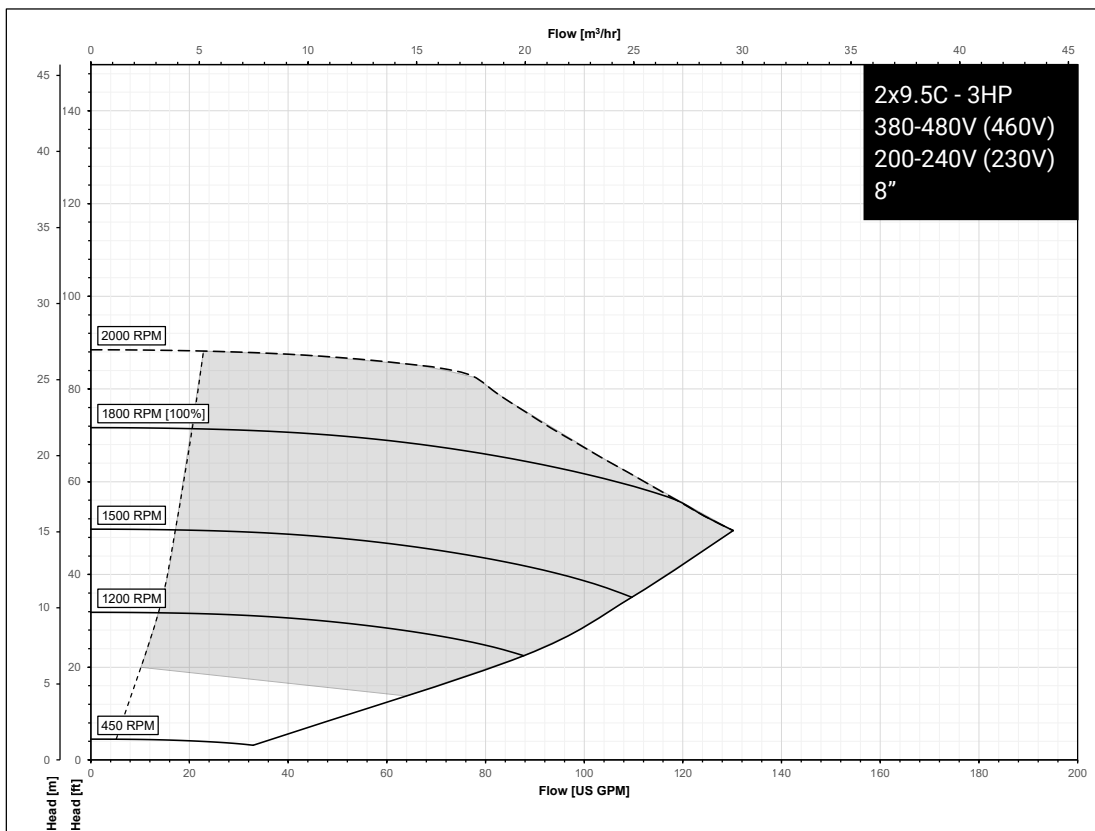

# Series e-80SCX performance curves for low speed models

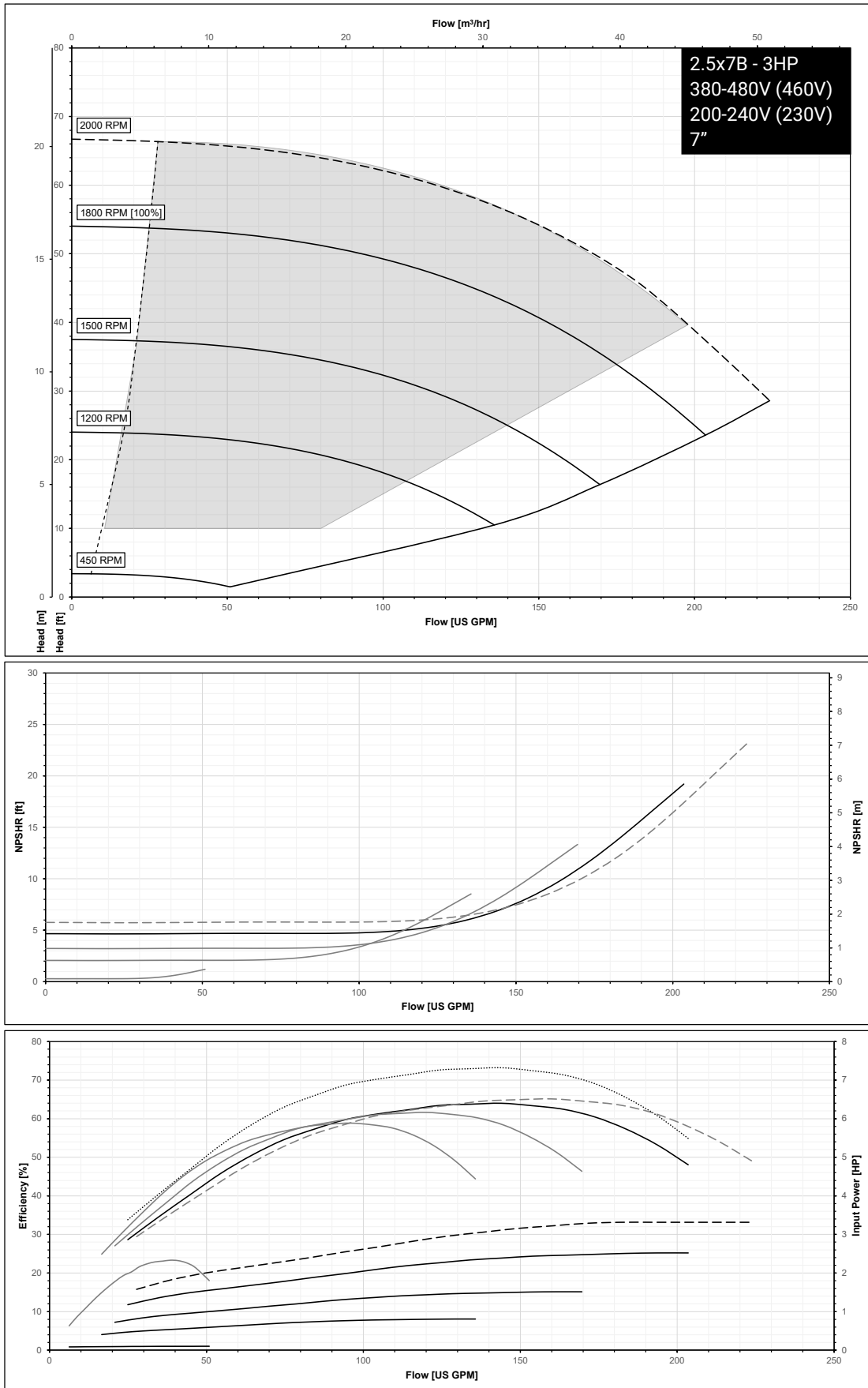

# Series e-80SCX performance curves for low speed models

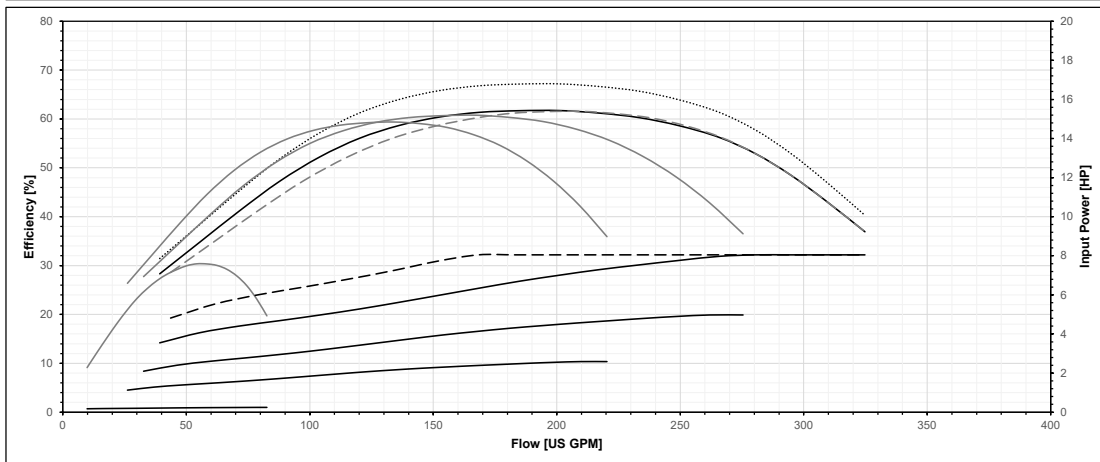
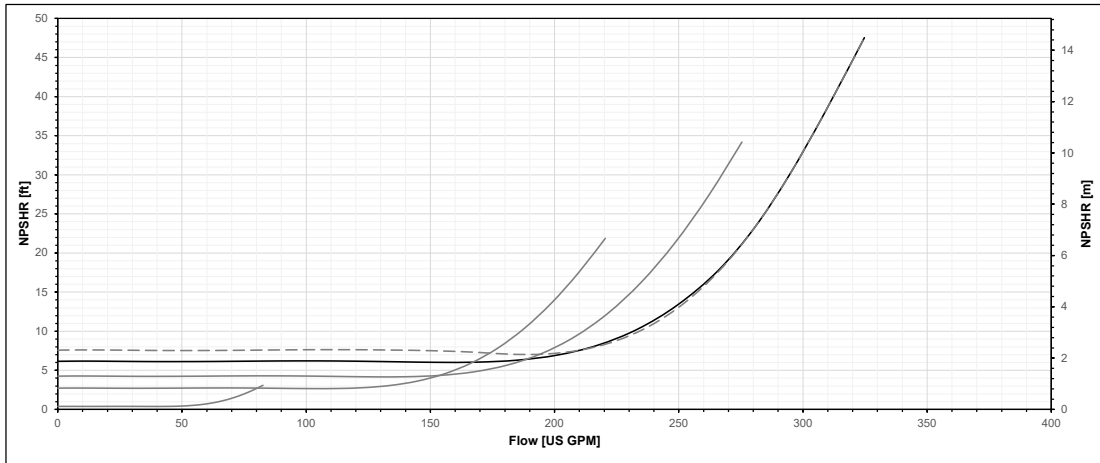
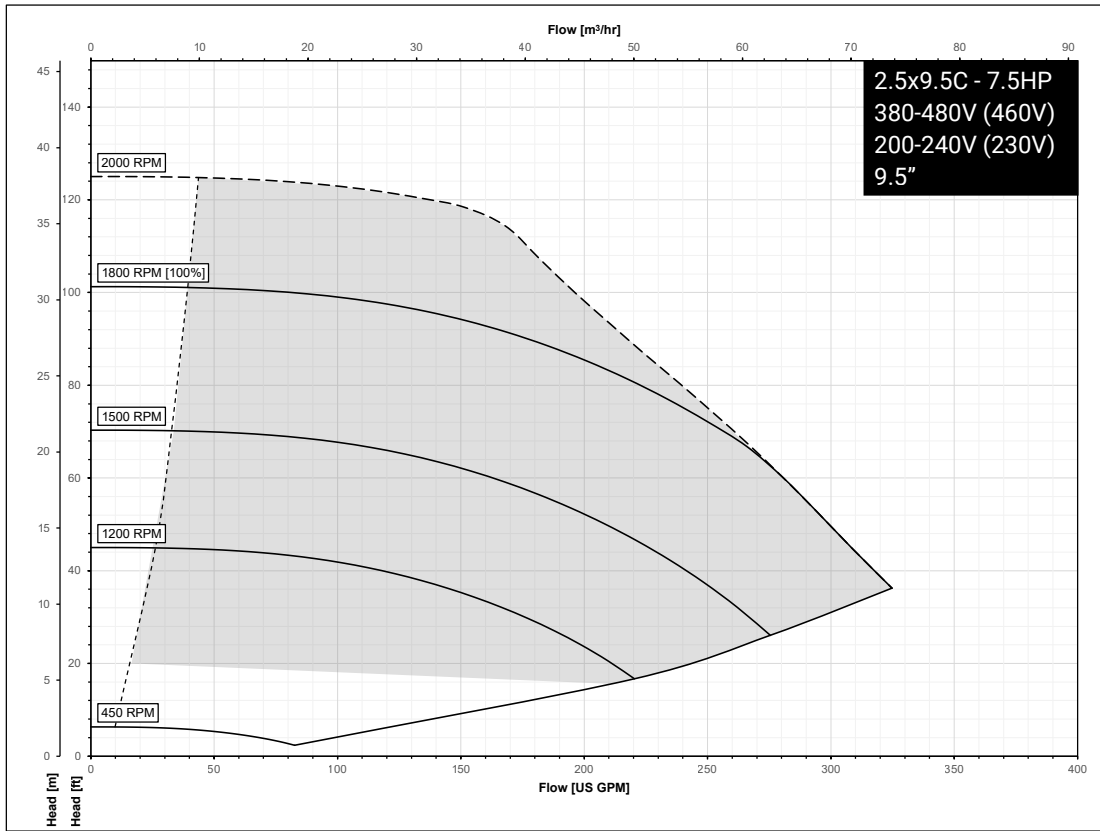

# Series e-80SCX performance curves for low speed models

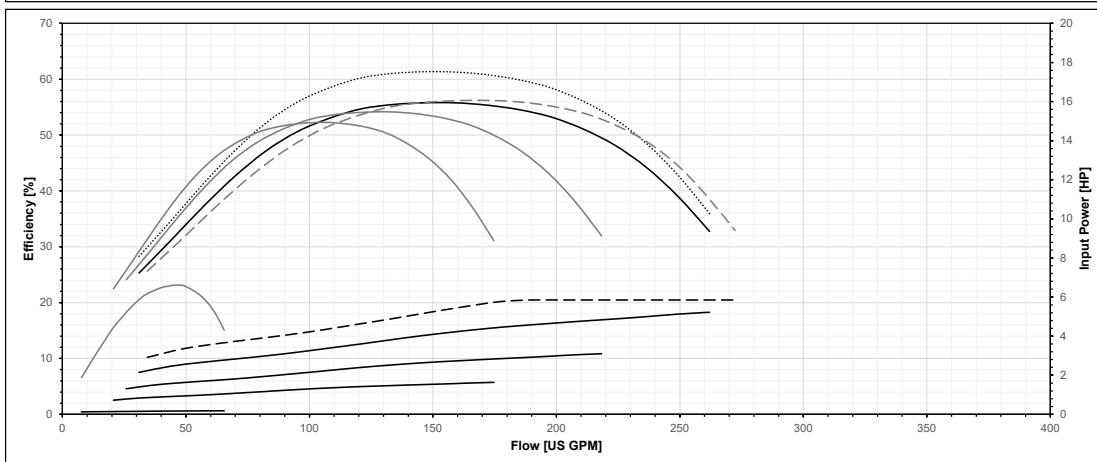
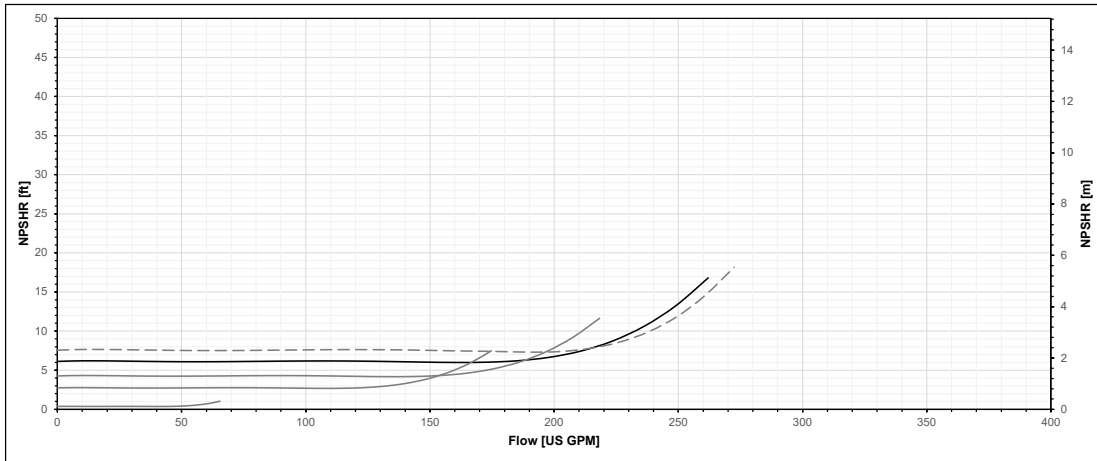
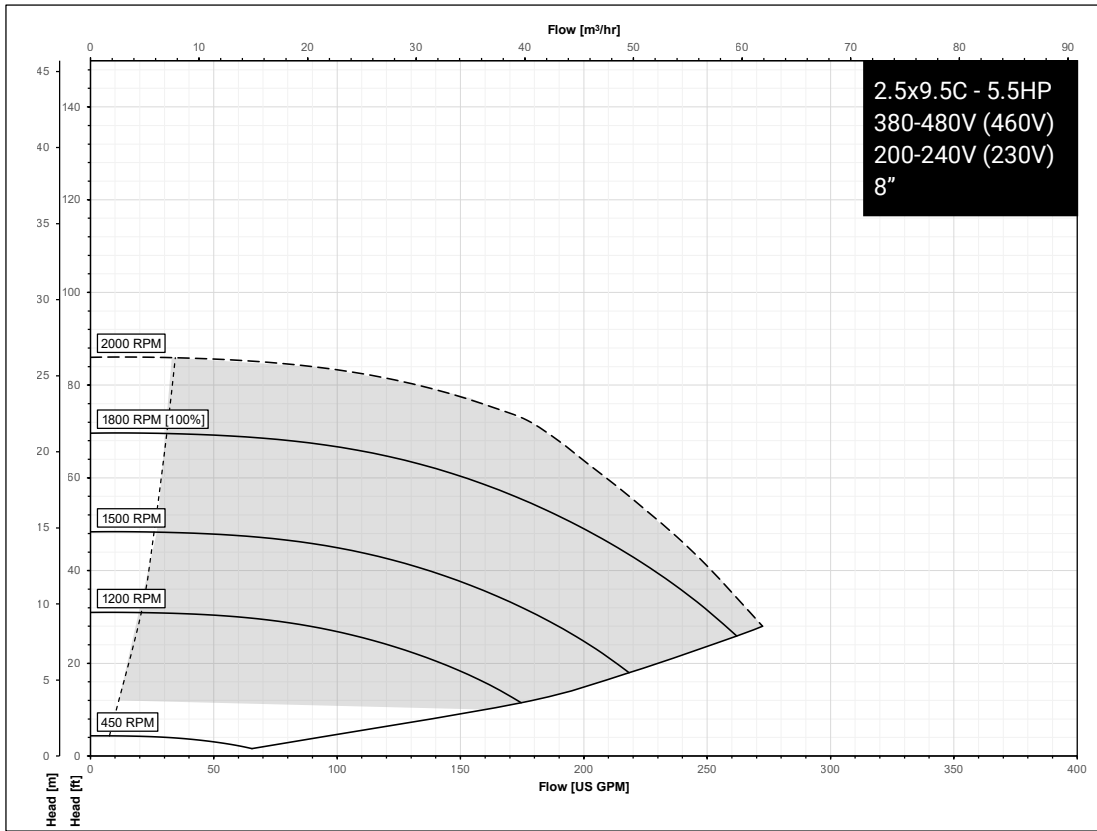

# Series e-80SCX performance curves for low speed models

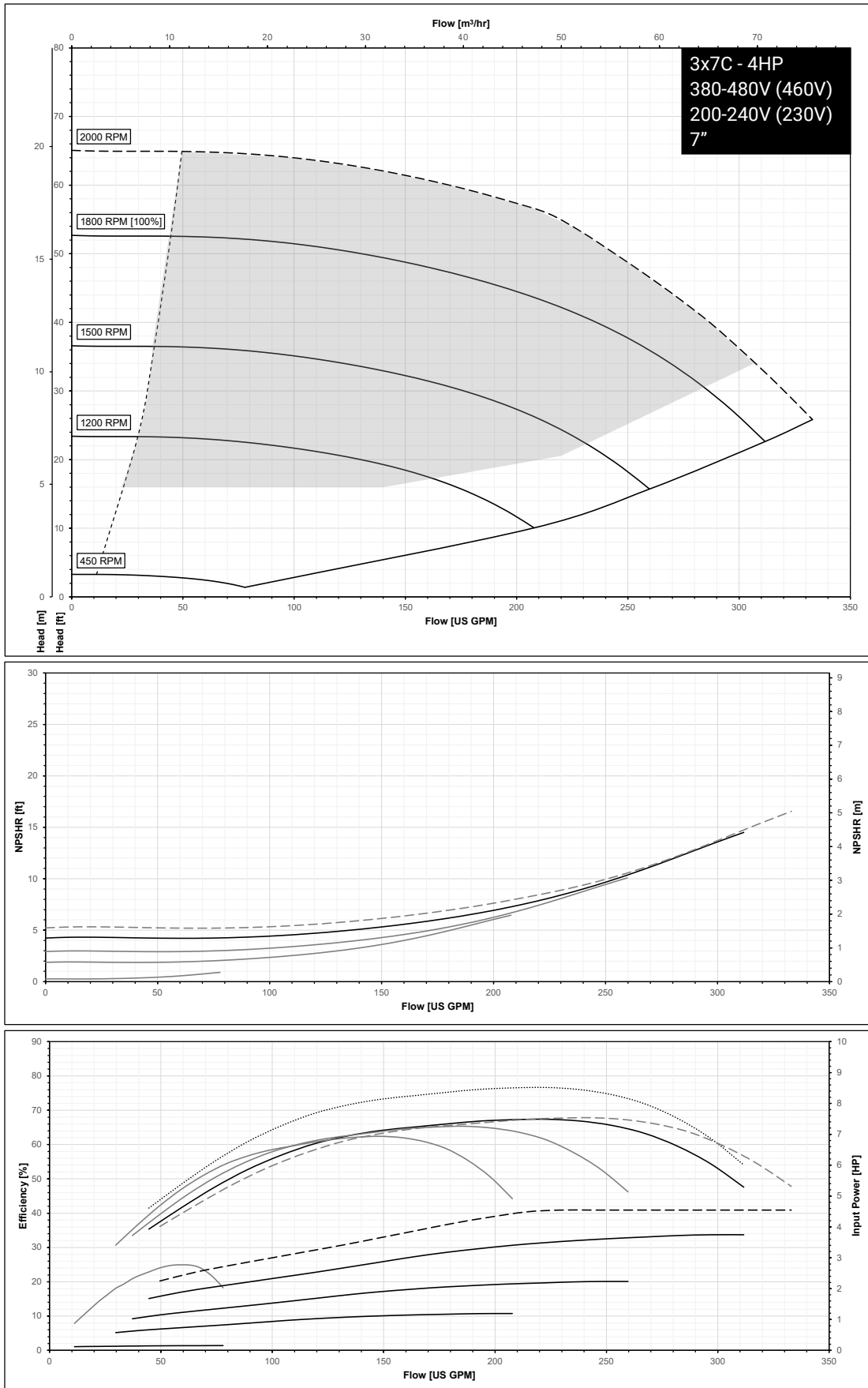

# Series e-80SCX performance curves for low speed models

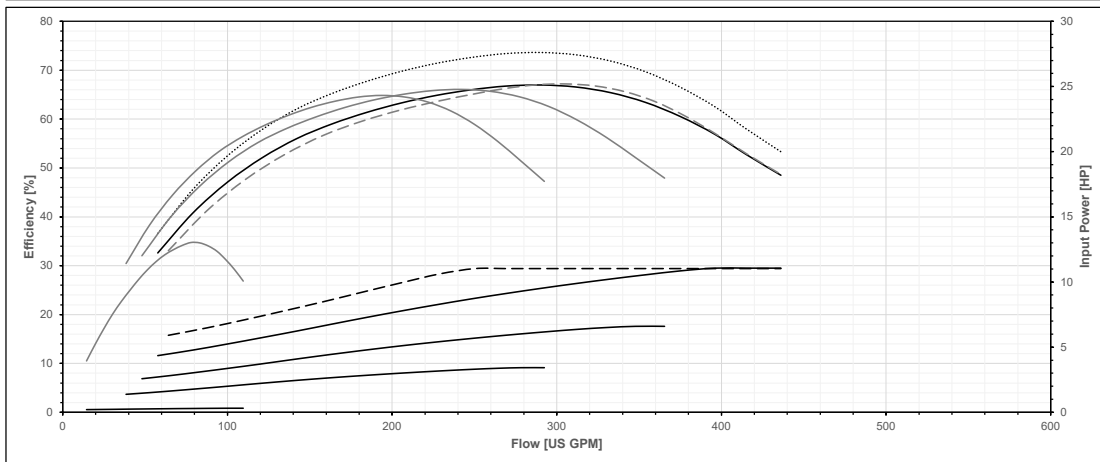
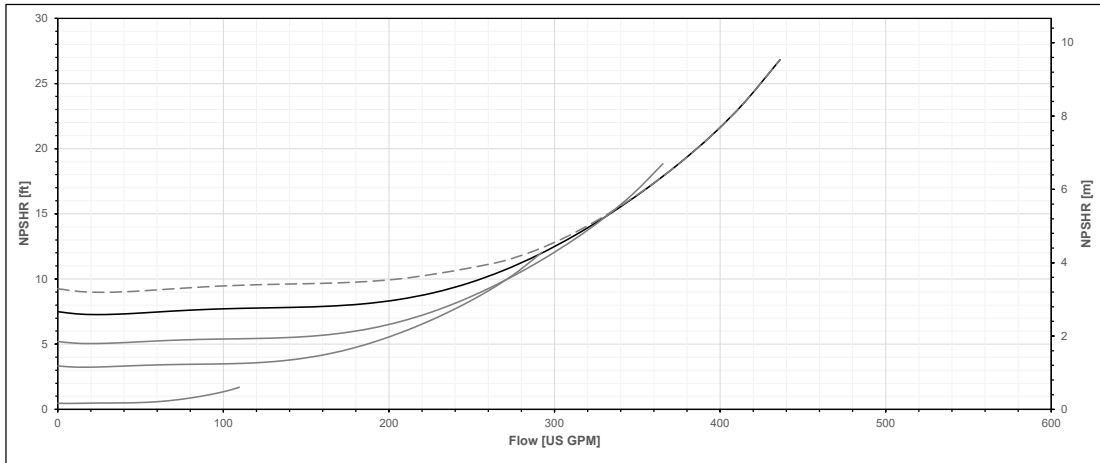
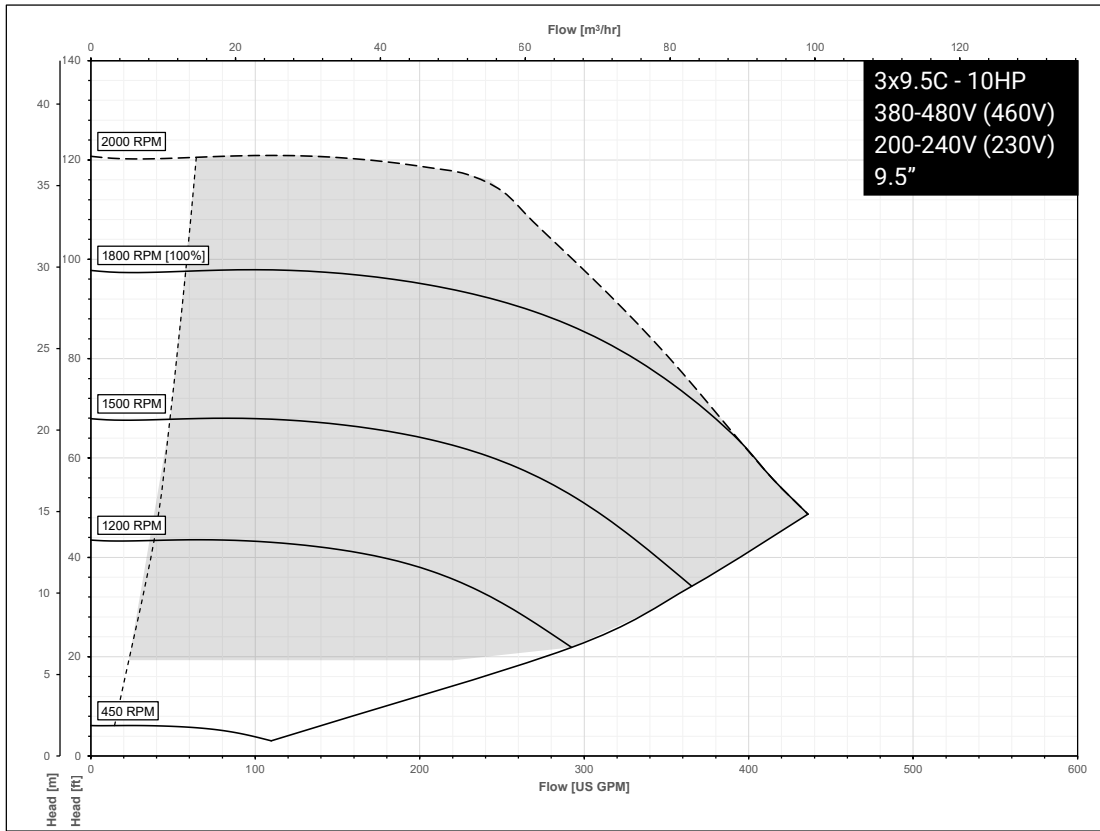

## Series e-80SCX performance curves for low speed models

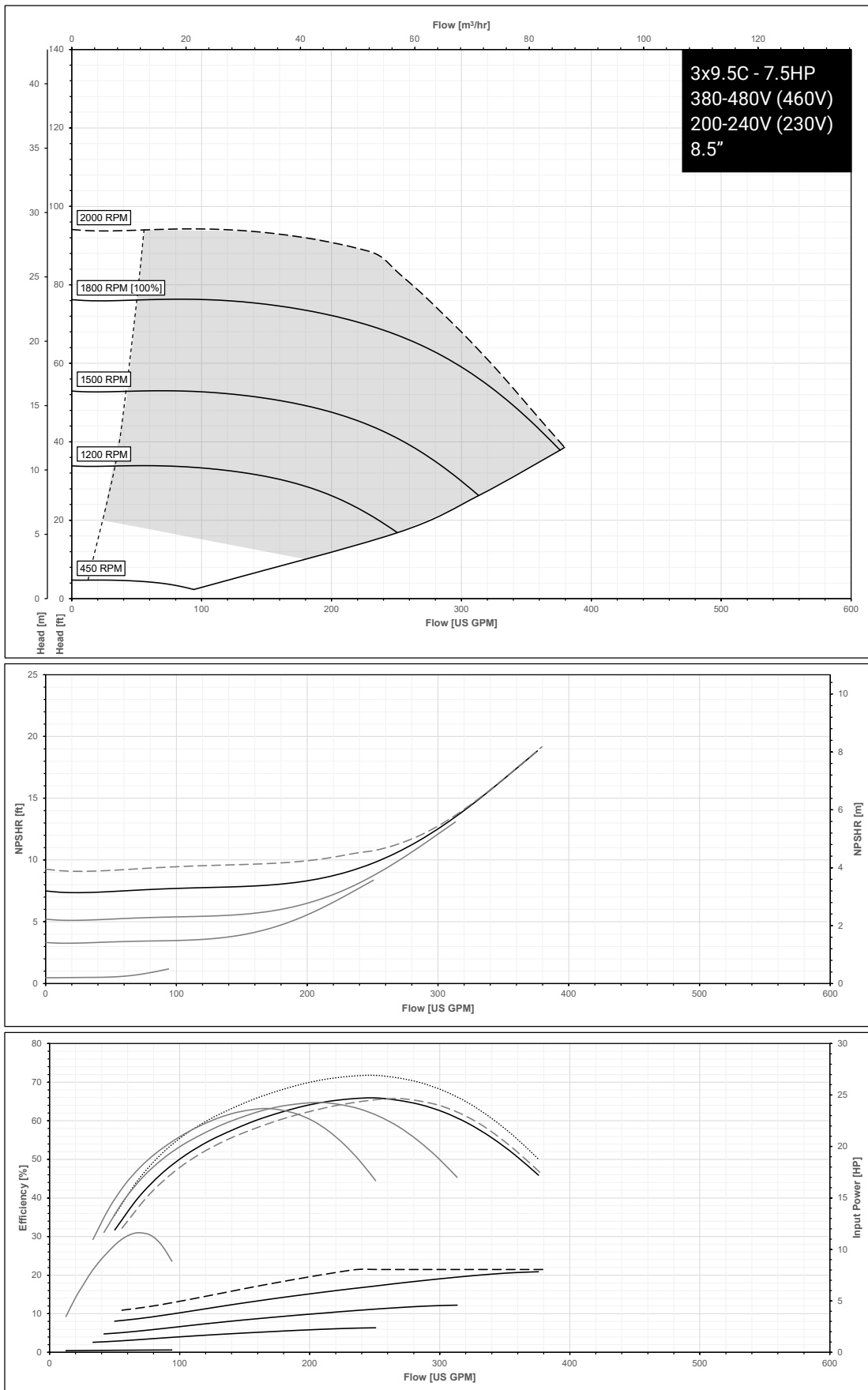

# Series e-80SCX performance curves for low speed models

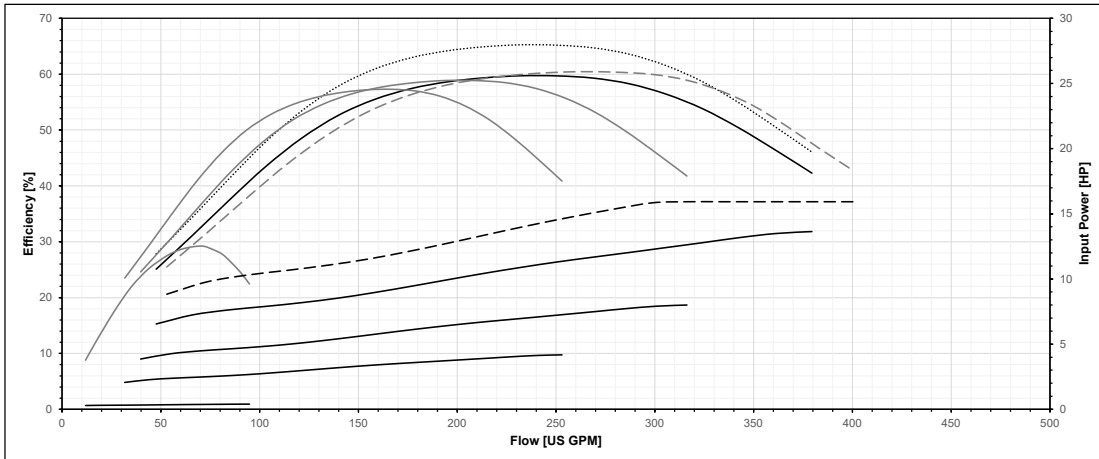
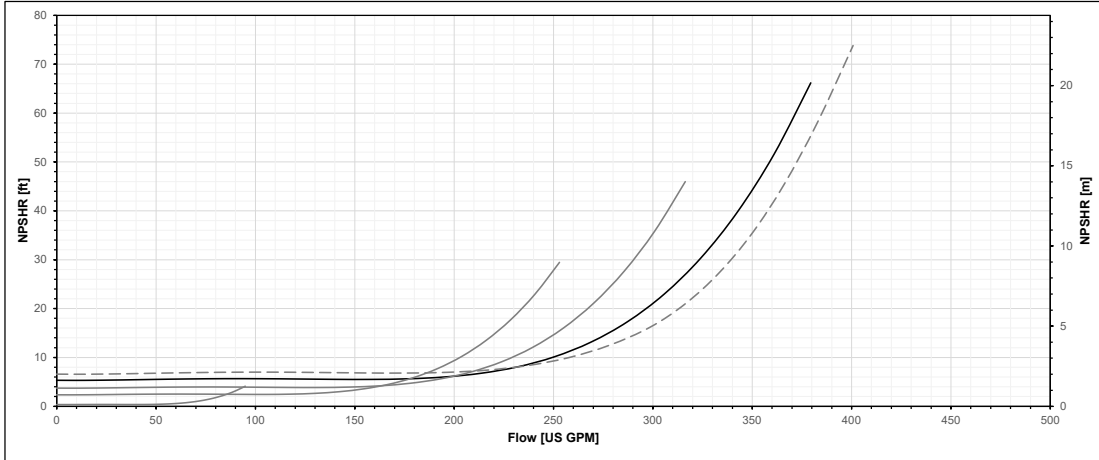
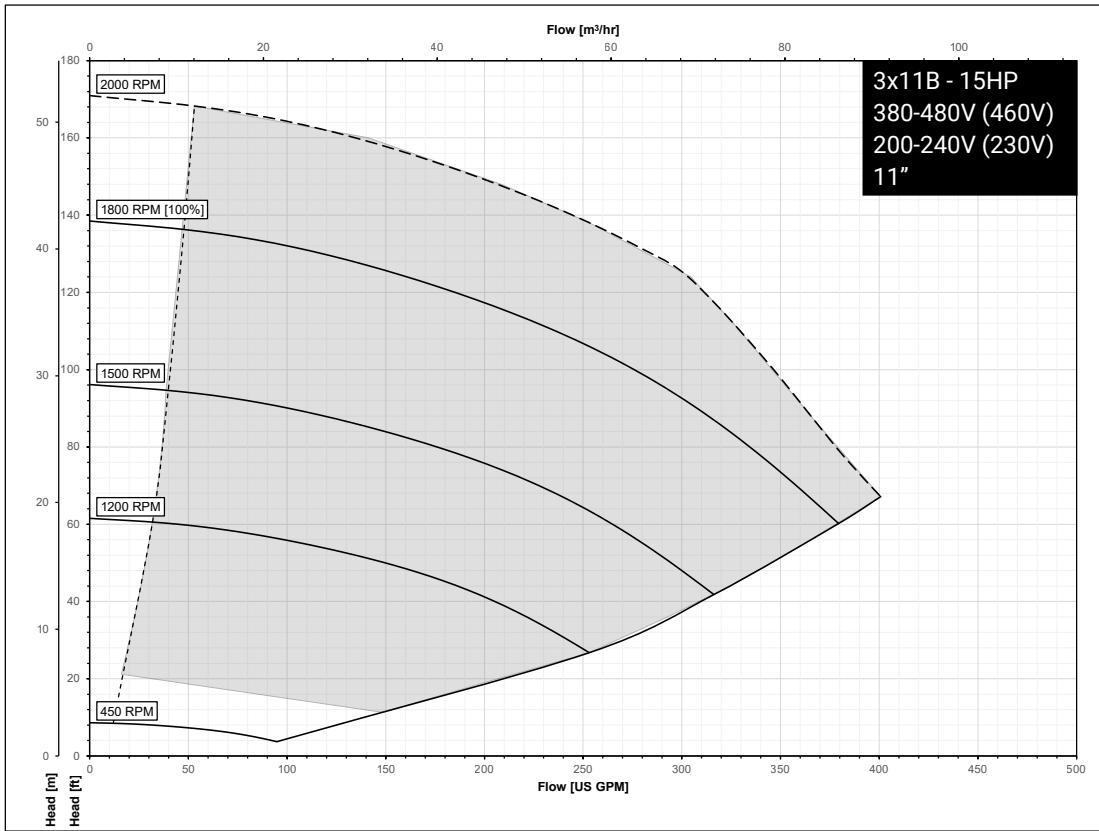

# Series e-80SCX performance curves for low speed models

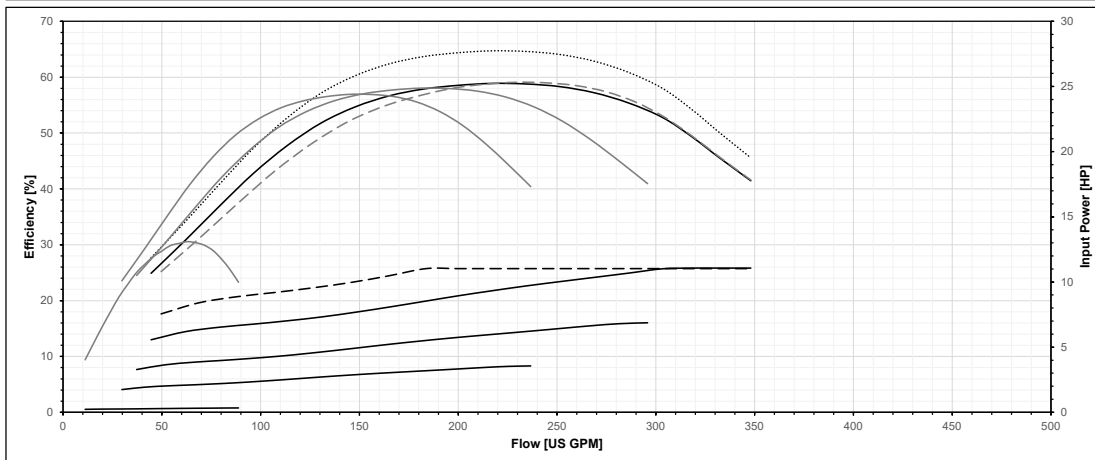
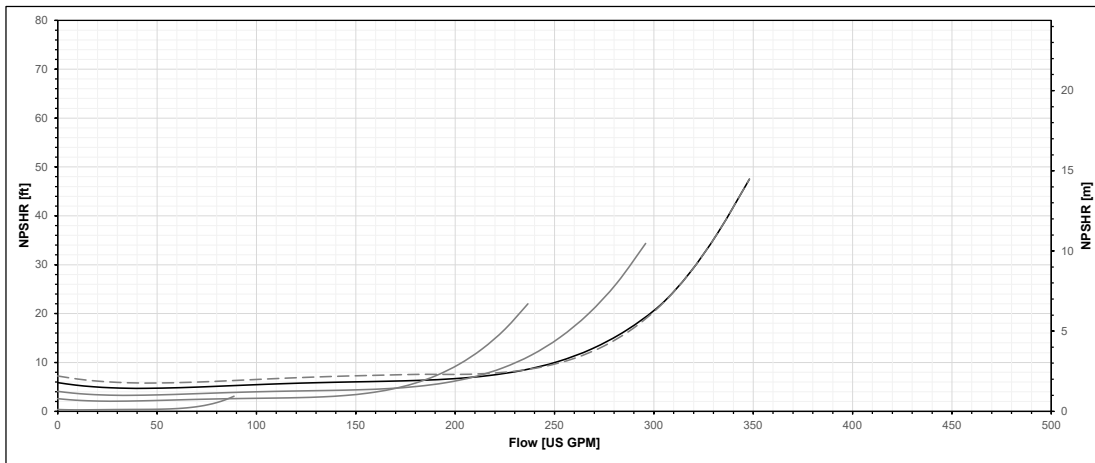
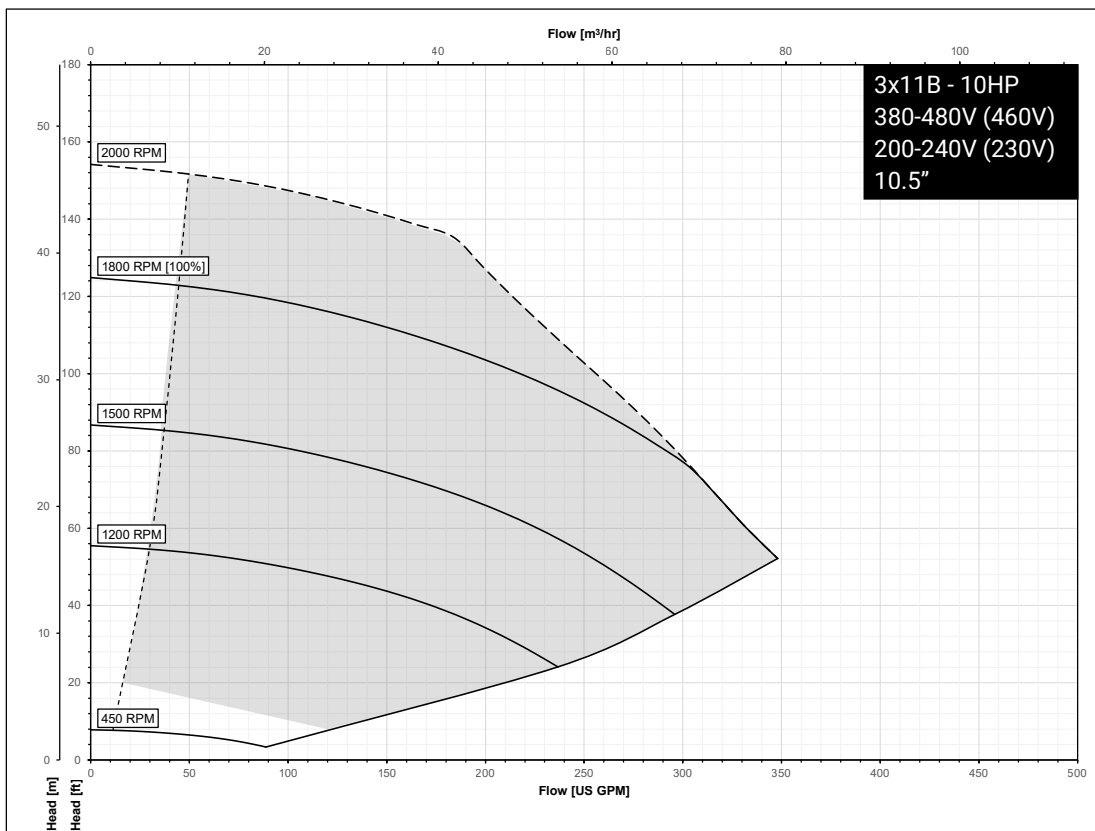

# Series e-80SCX performance curves for low speed models

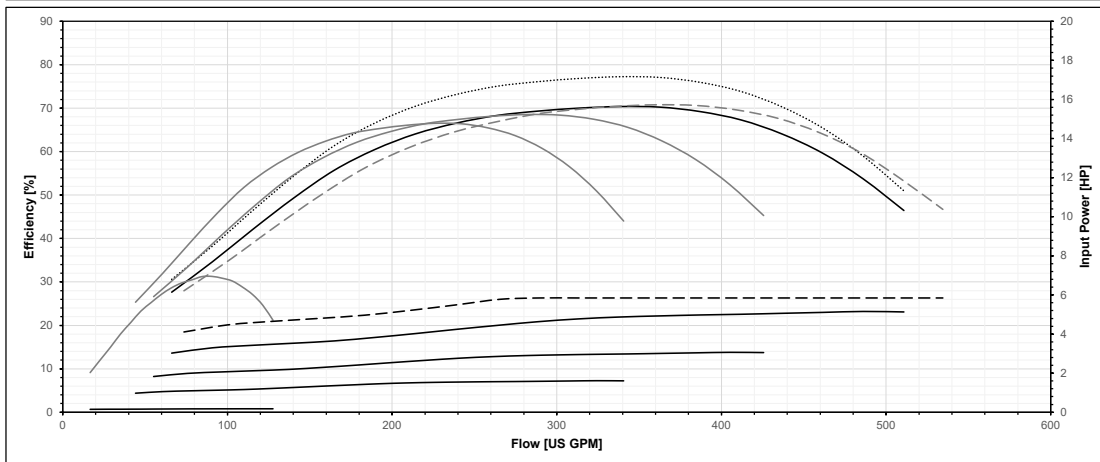
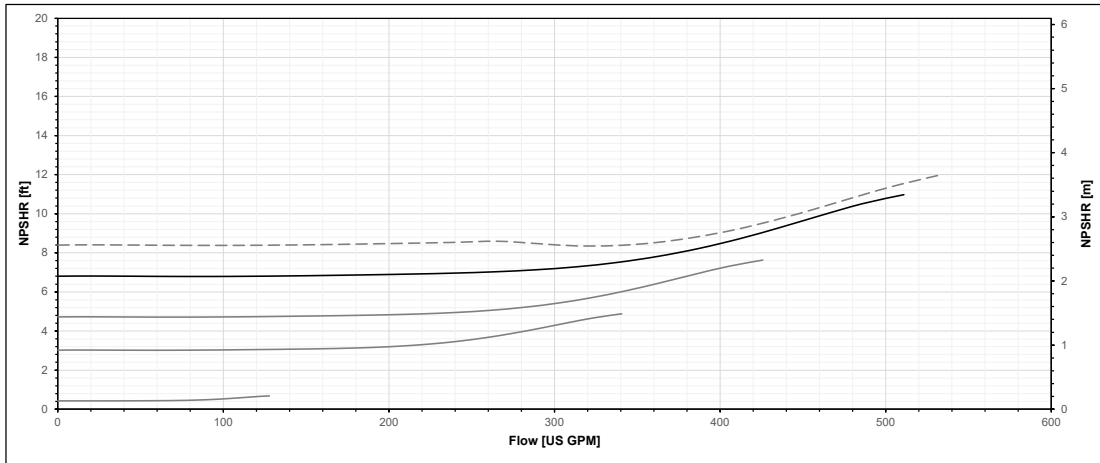
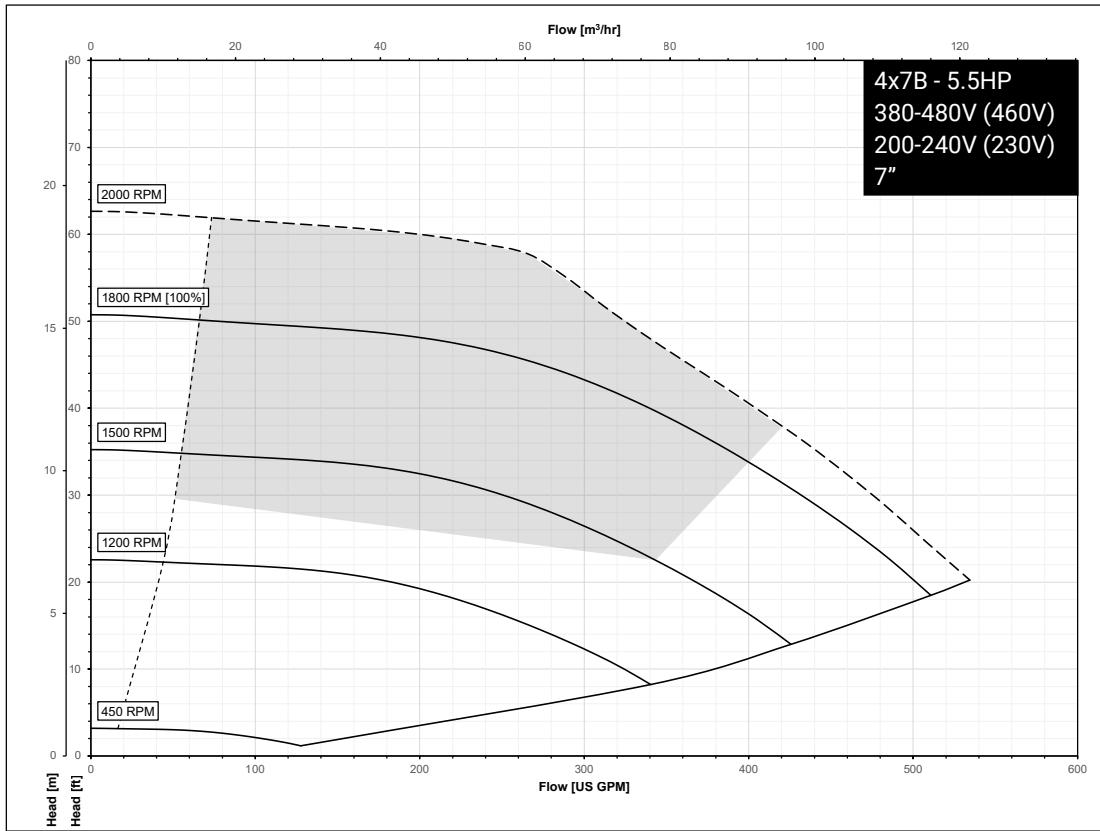

# Series e-80SCX performance curves for low speed models

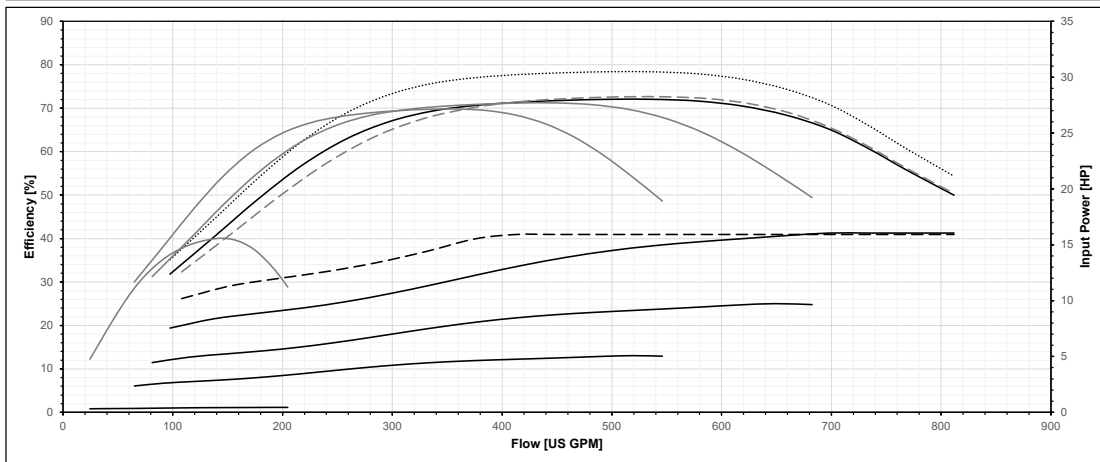
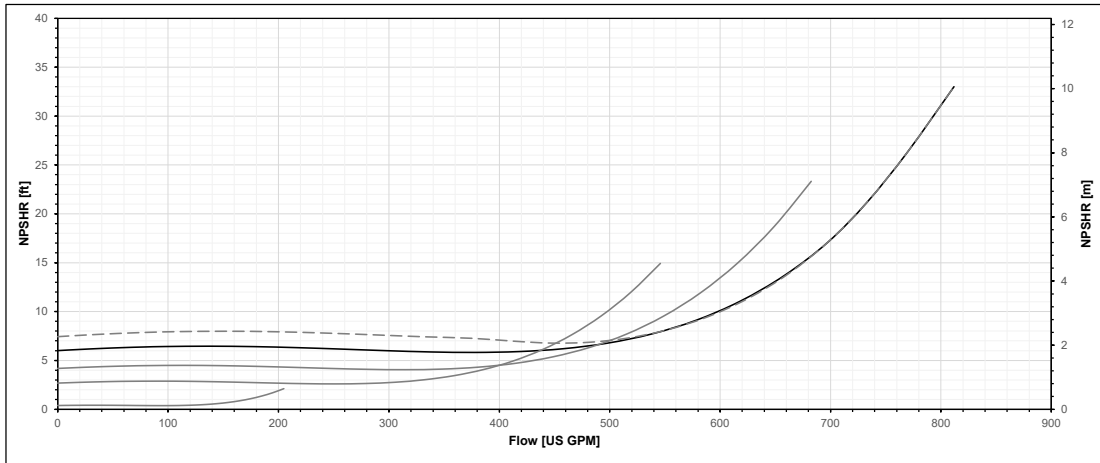
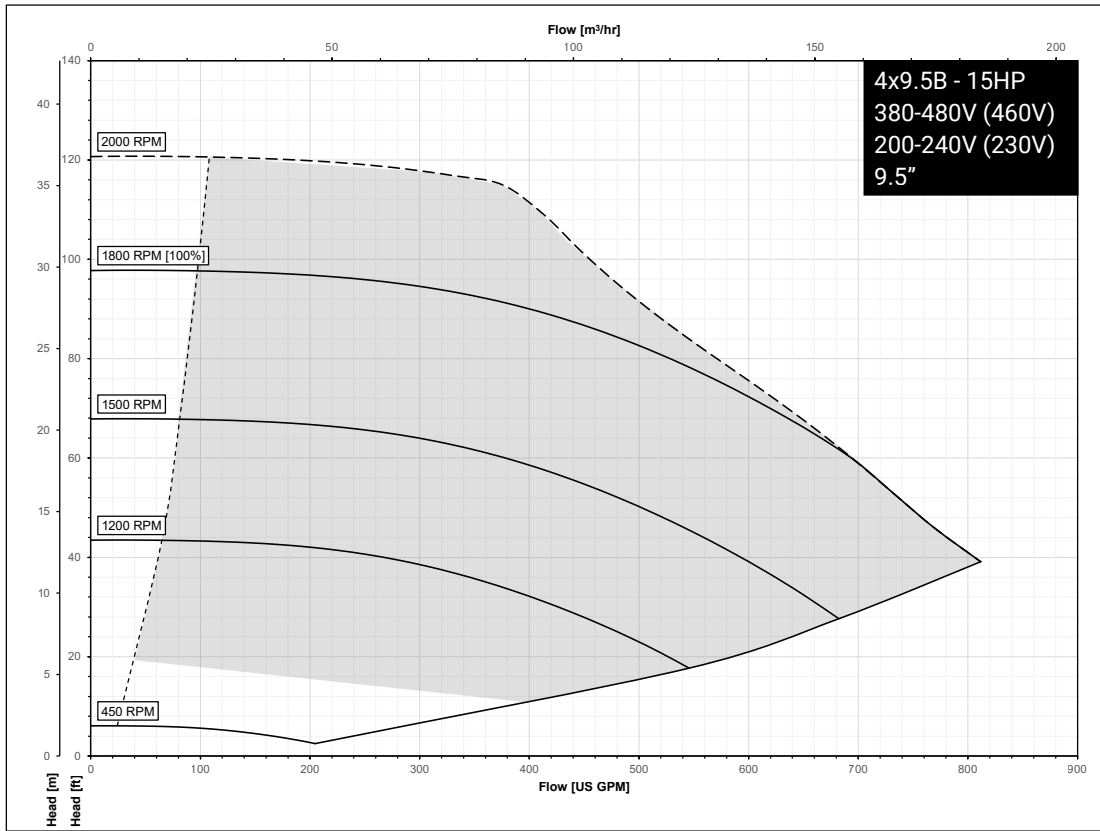

# Series e-80SCX performance curves for low speed models

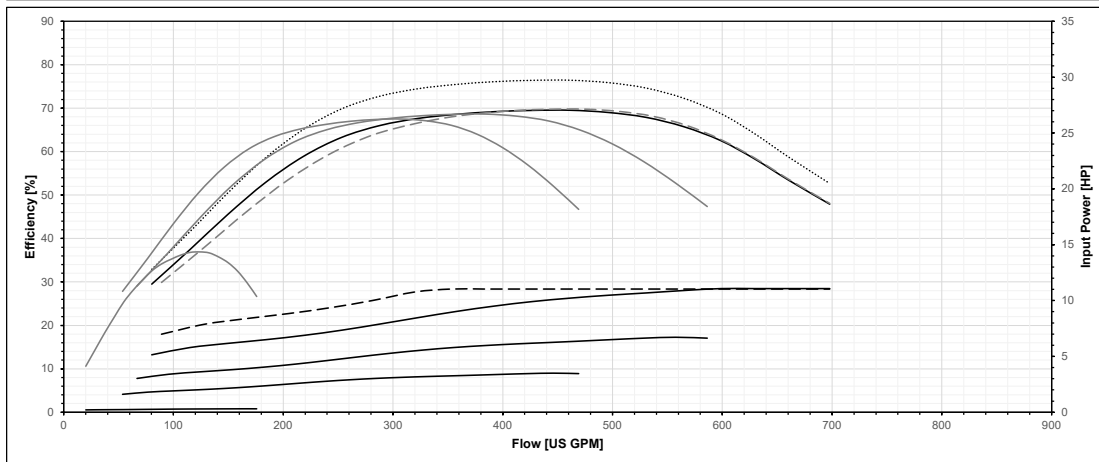
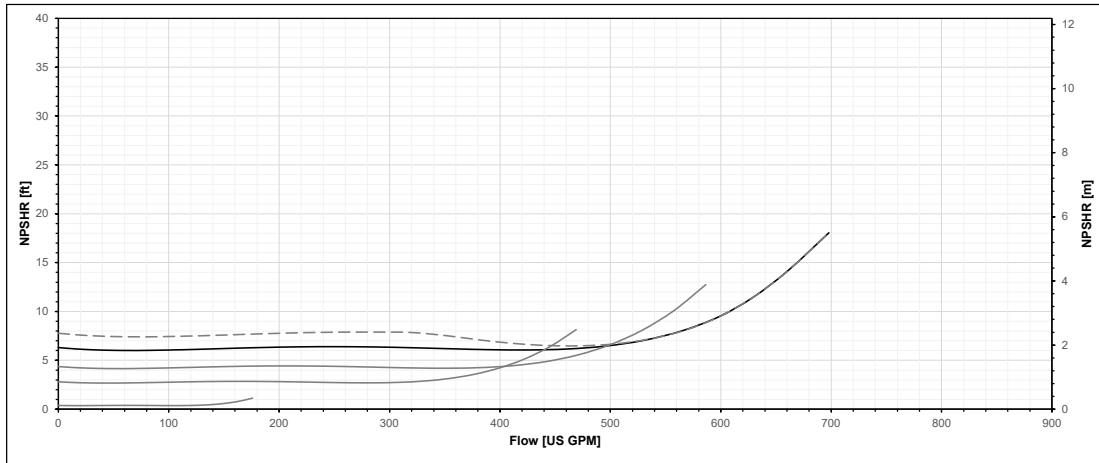
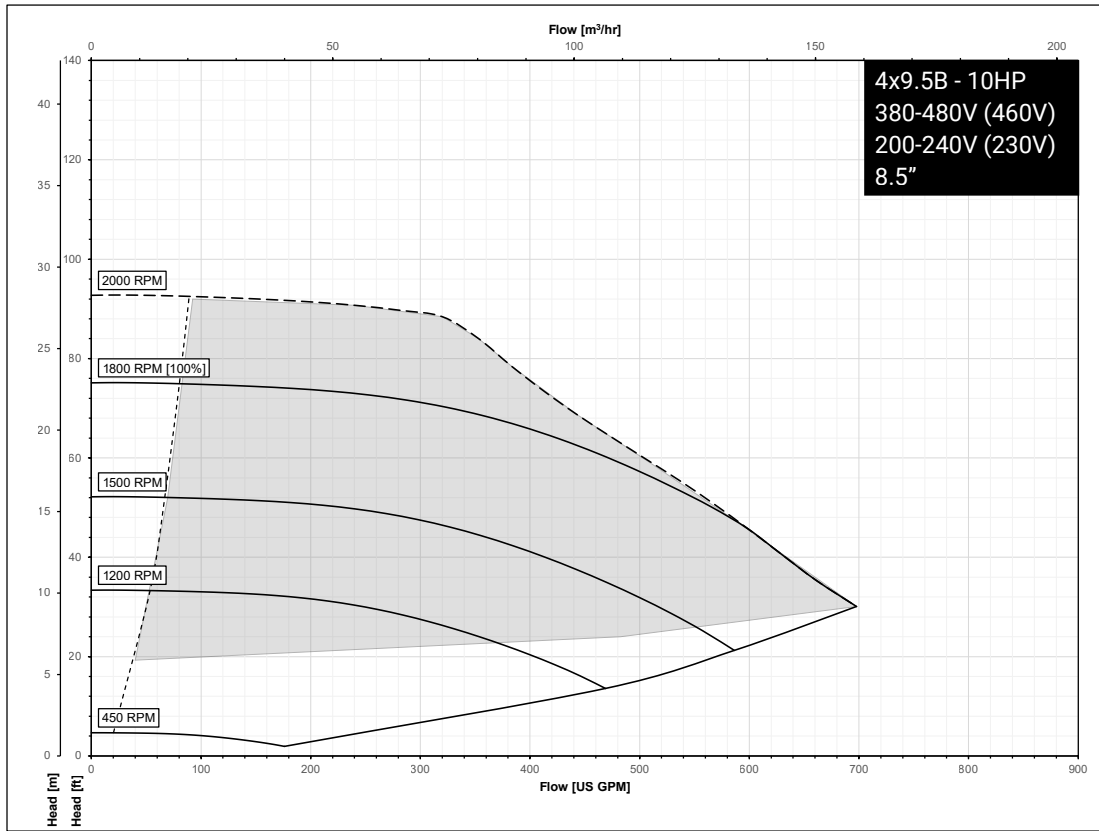

# Series e-80SCX performance curves for low speed models

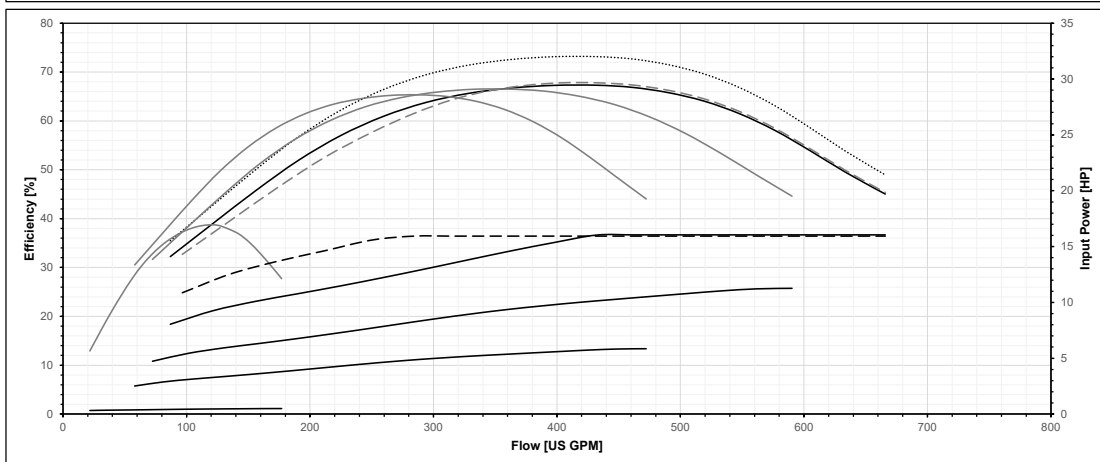
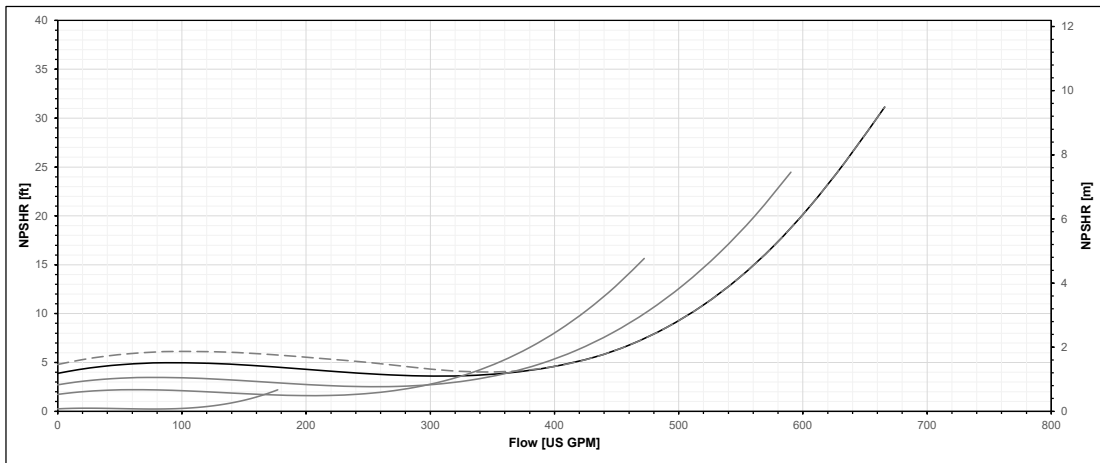
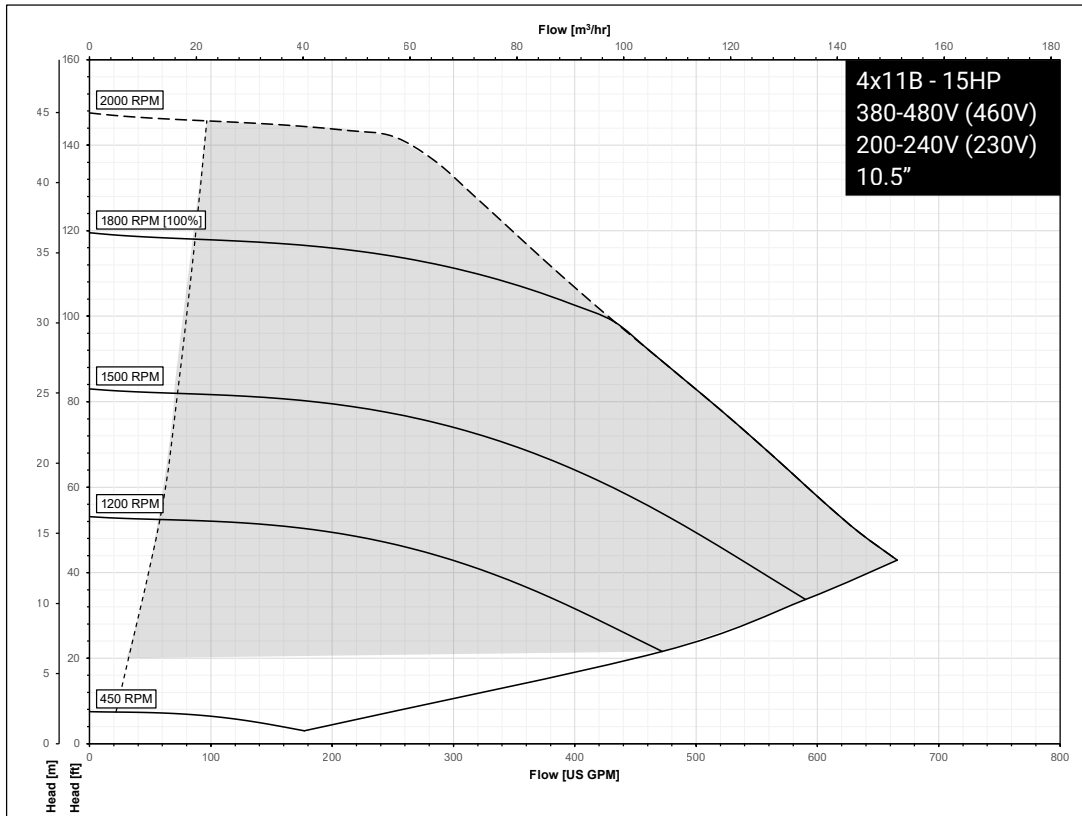

# Series e-80SCX performance curves for low speed models

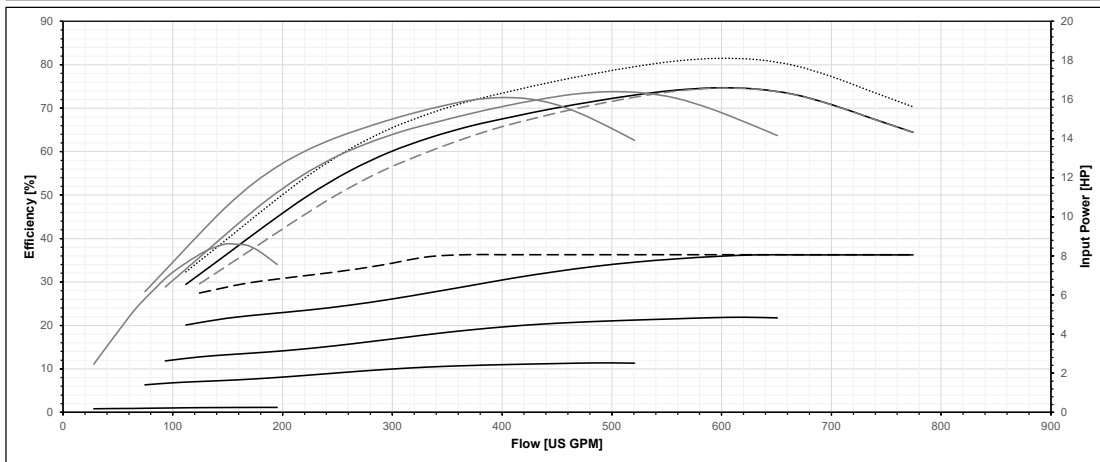
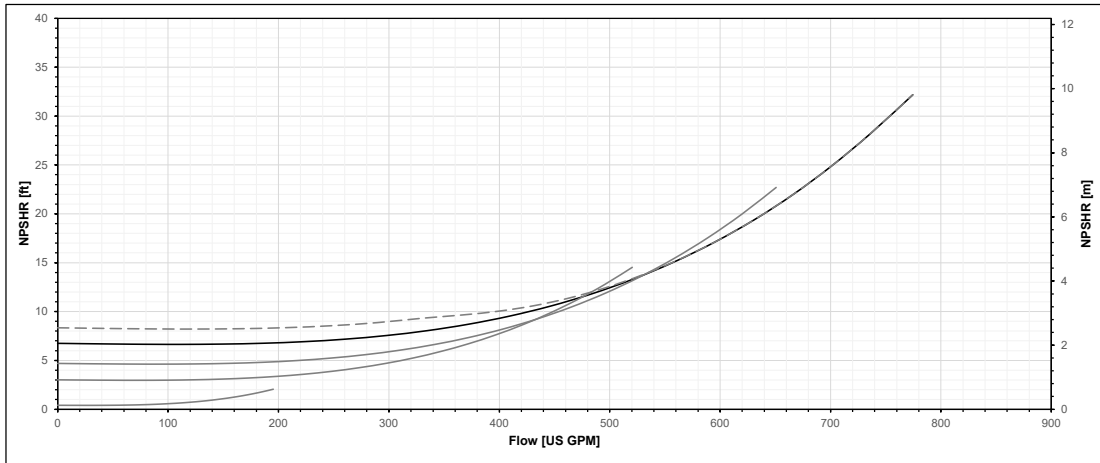
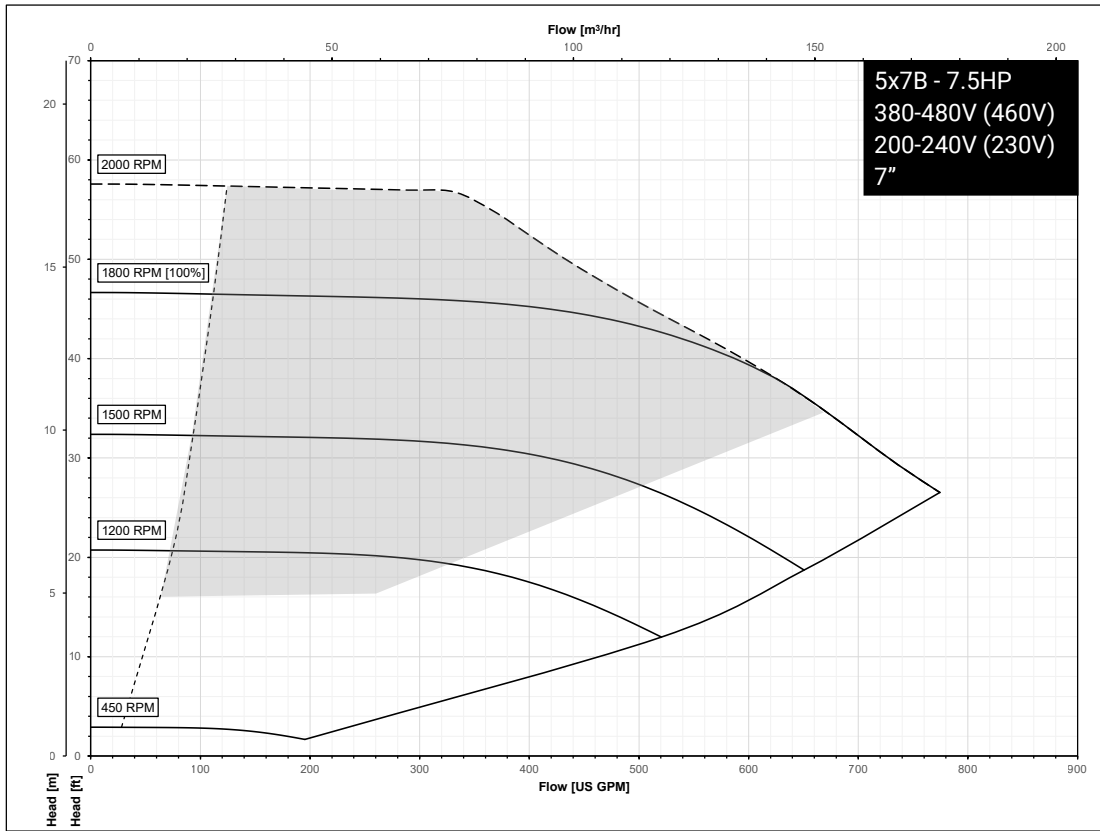

# Series e-80SCX performance curves for low speed models

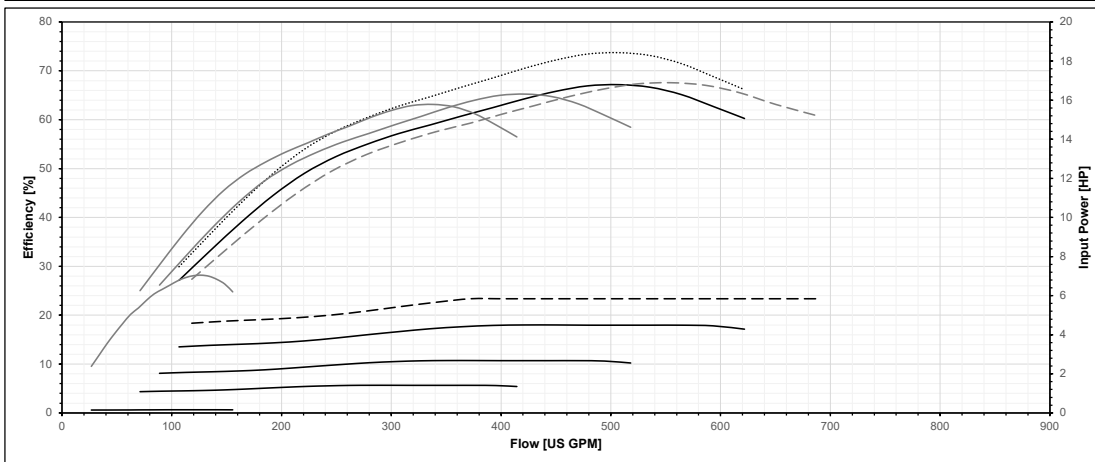
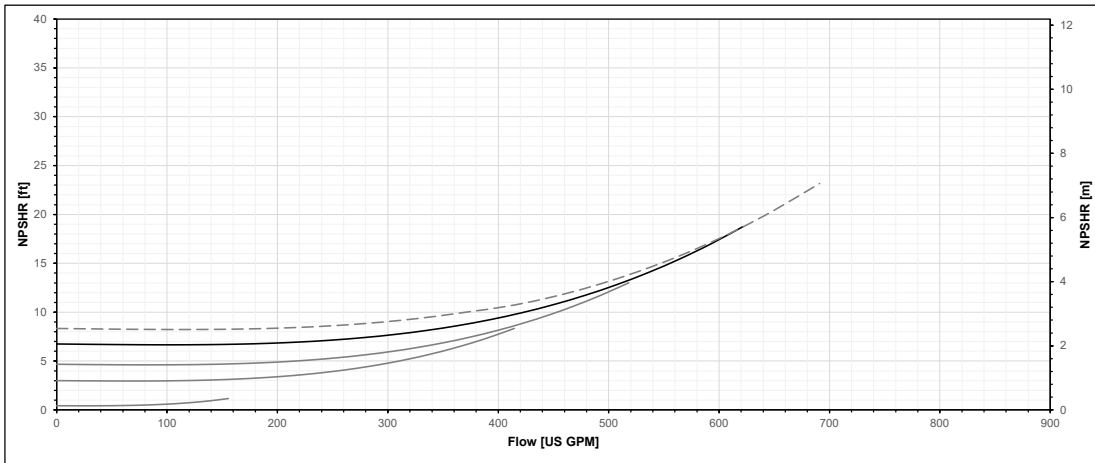
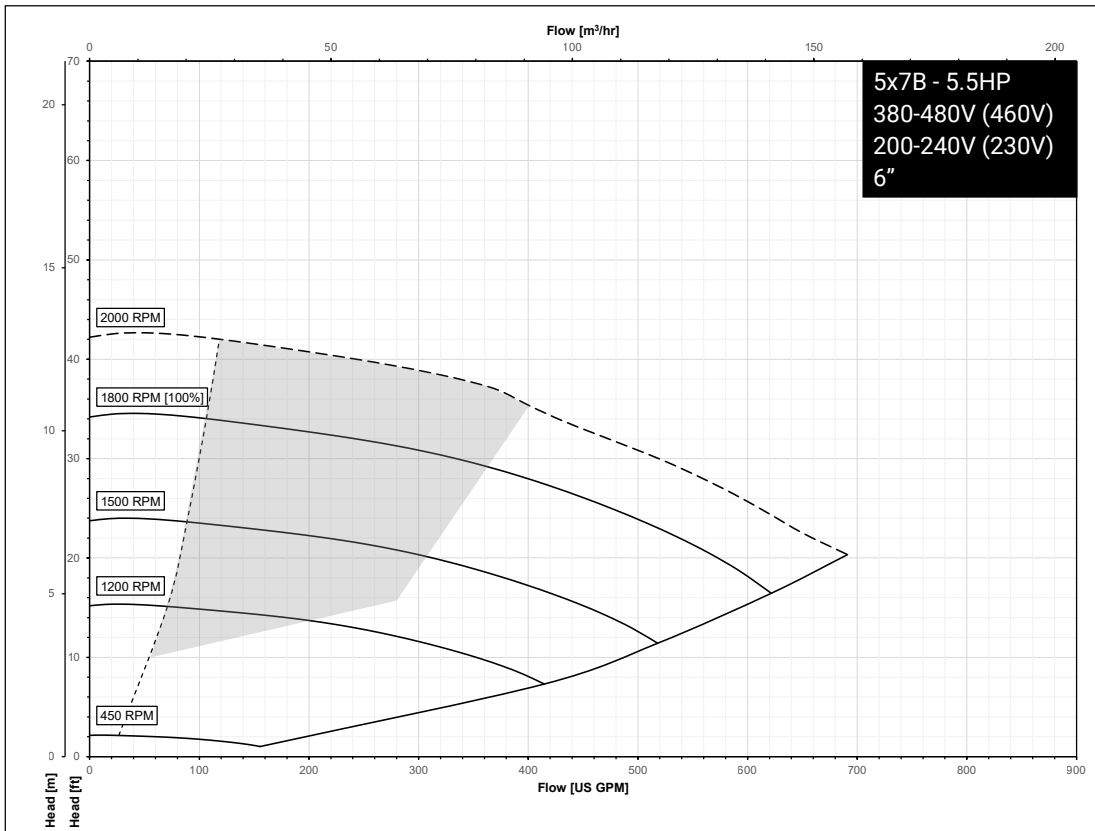

# Series e-80SCX performance curves for low speed models

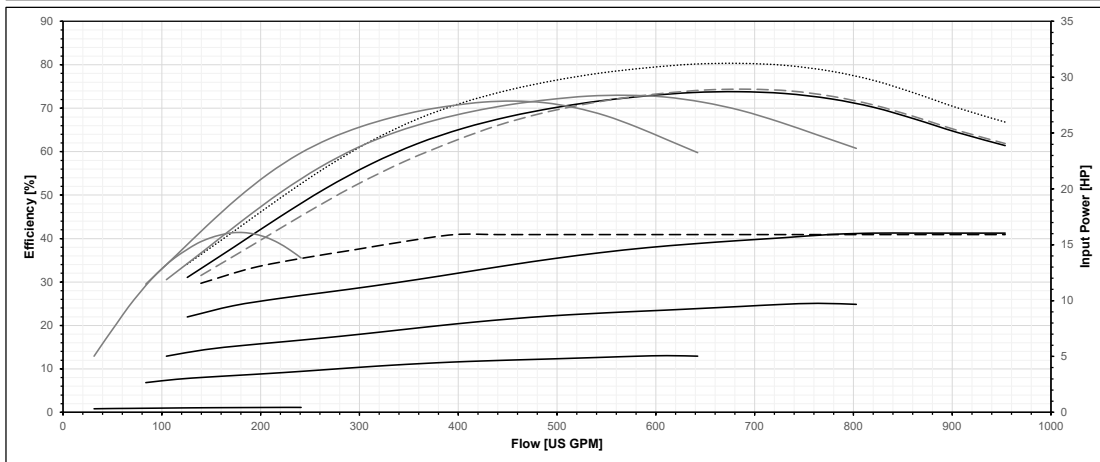
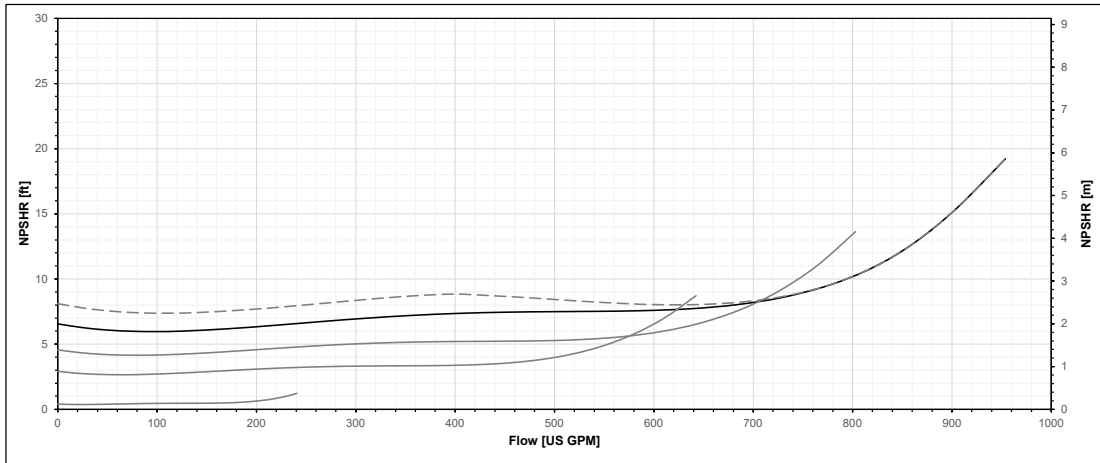
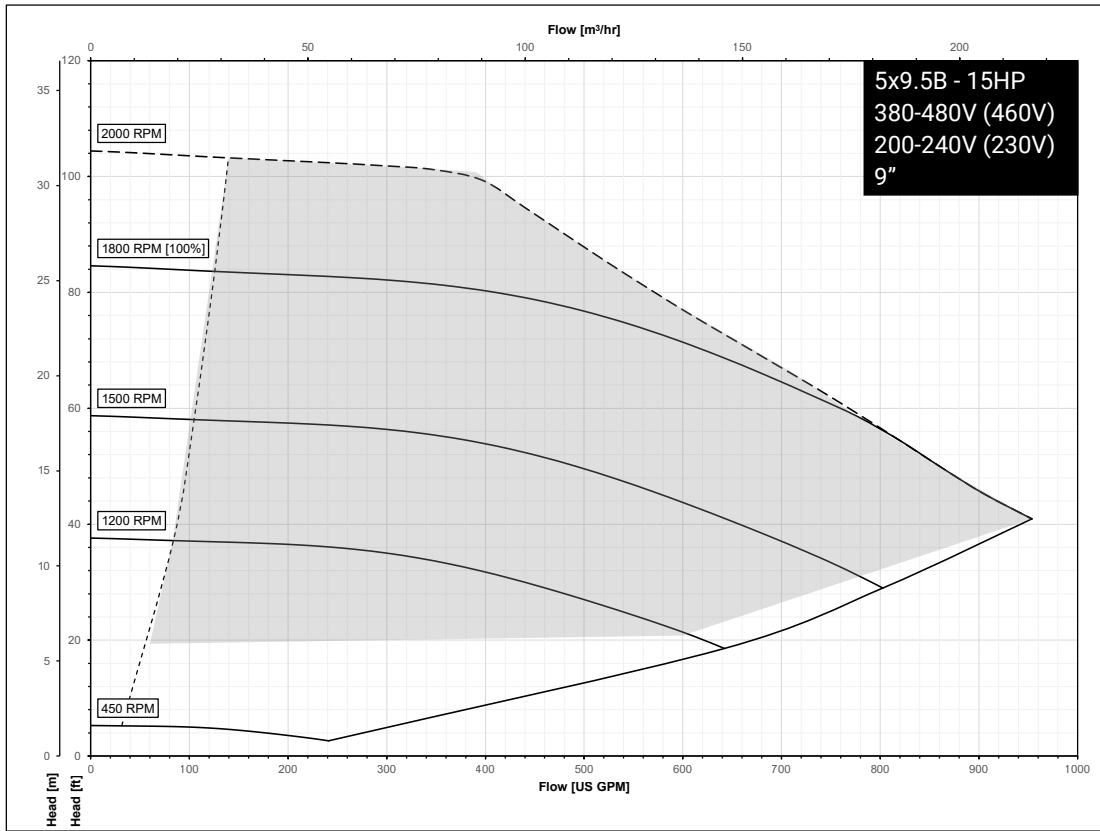

# Series e-80SCX performance curves for low speed models

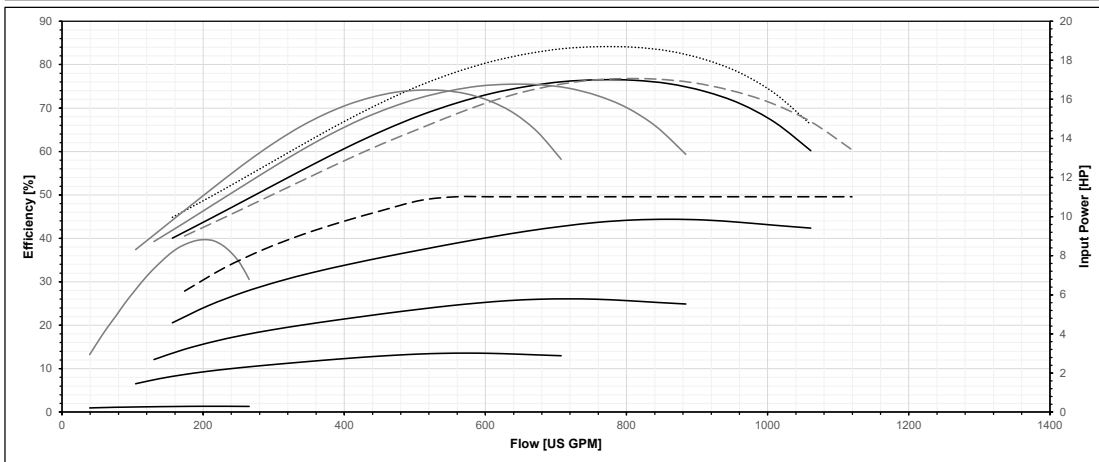
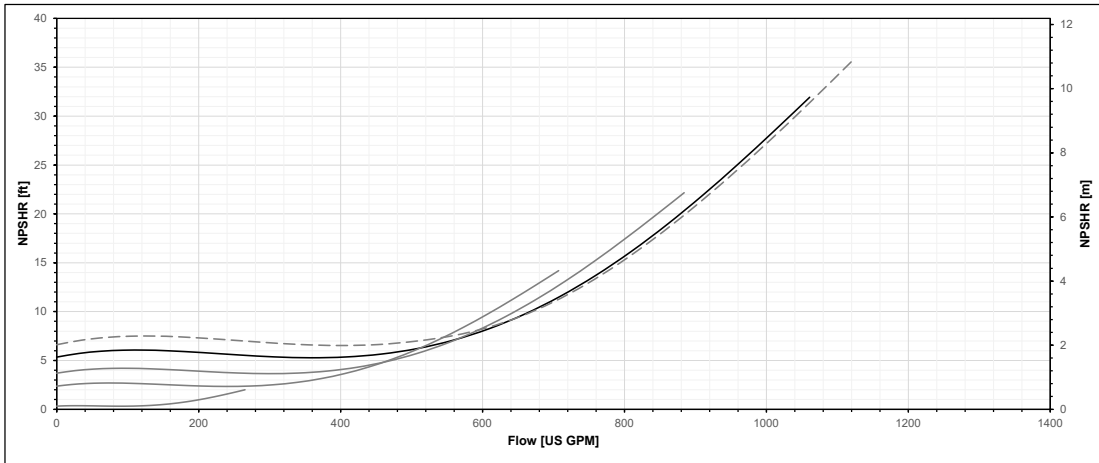
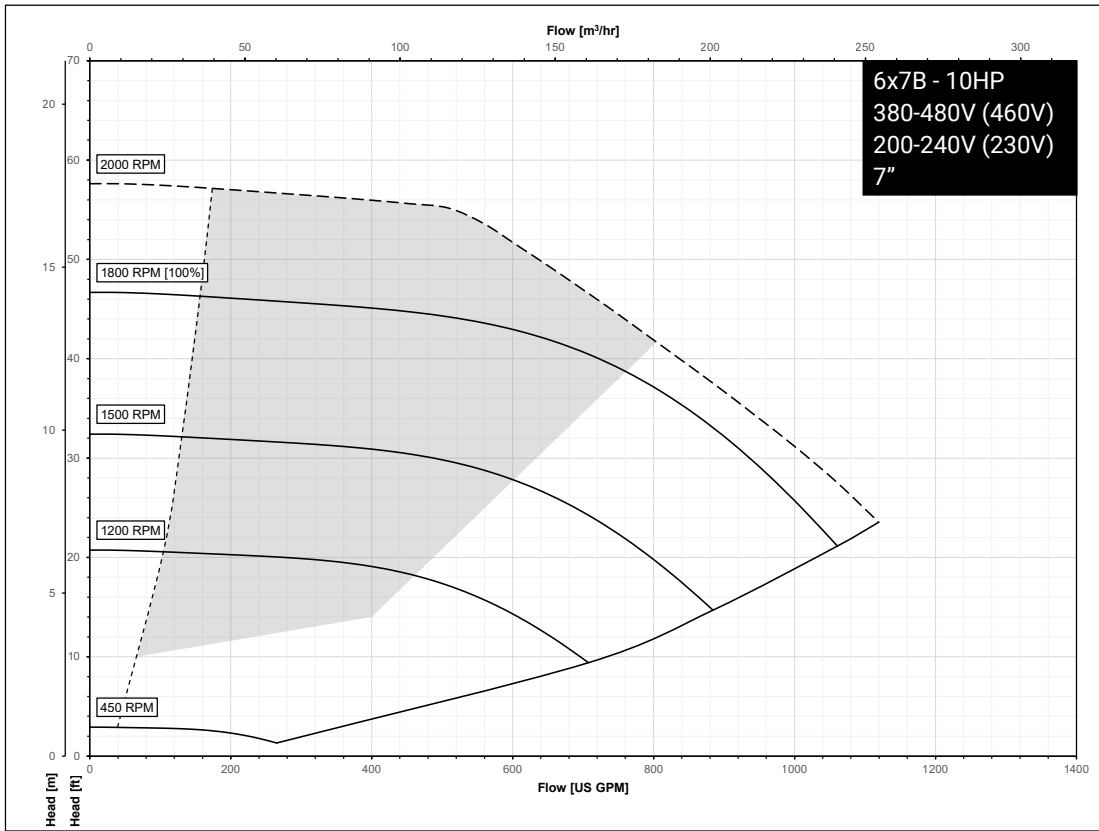

# Series e-80SCX performance curves for low speed models

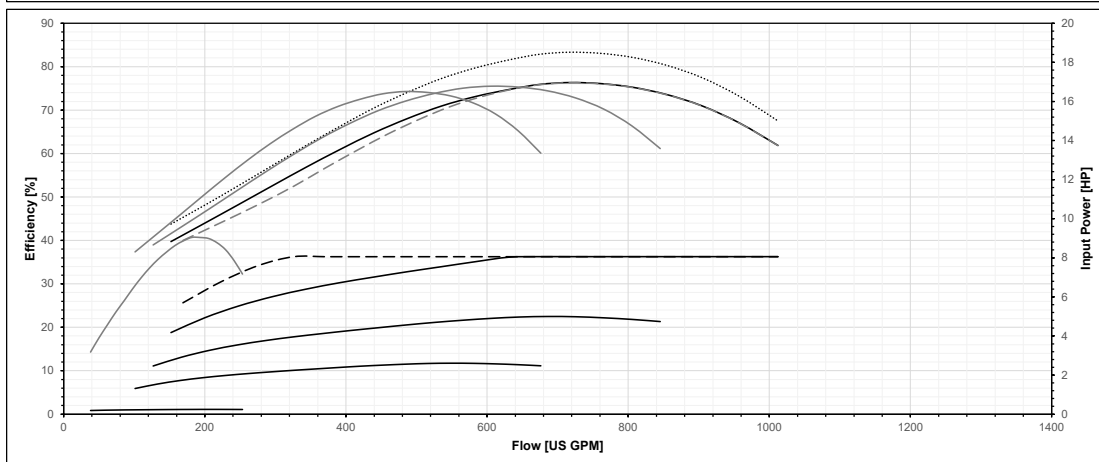
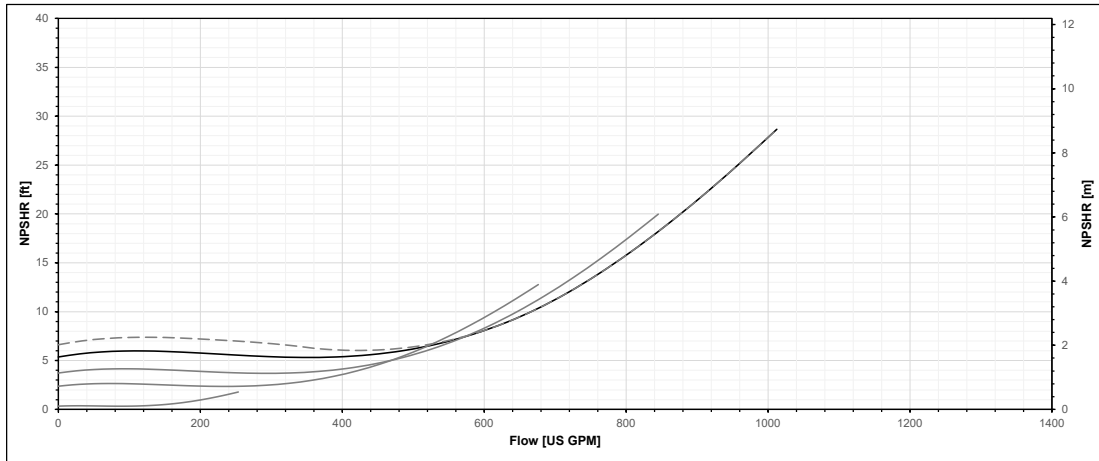
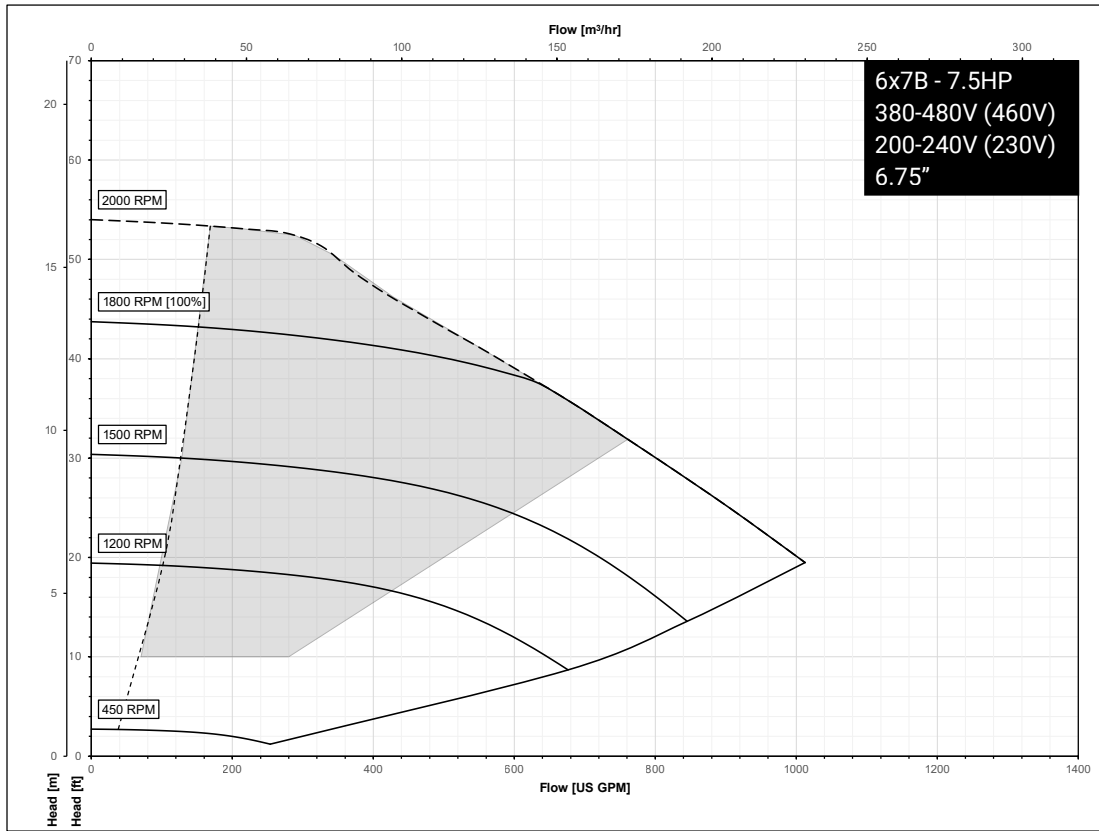

# Series e-80SCX performance curves for low speed models

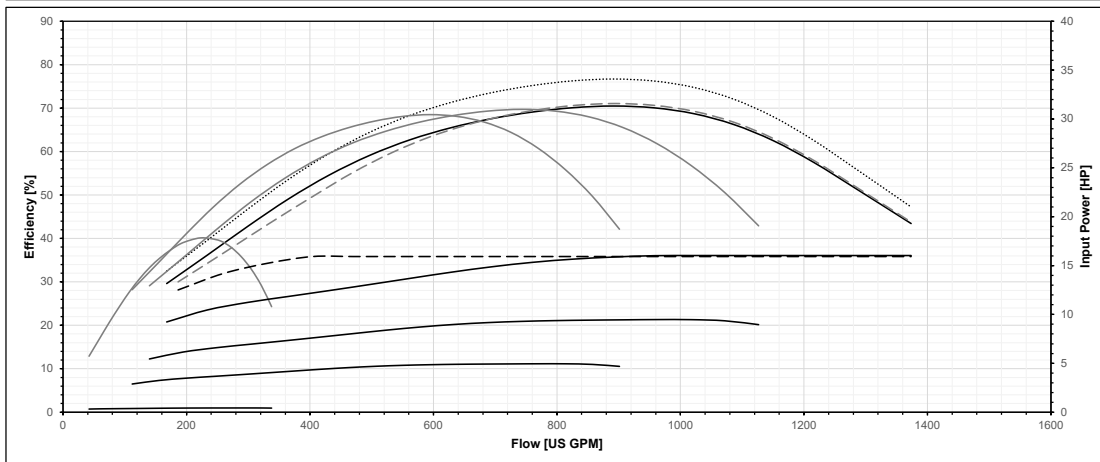
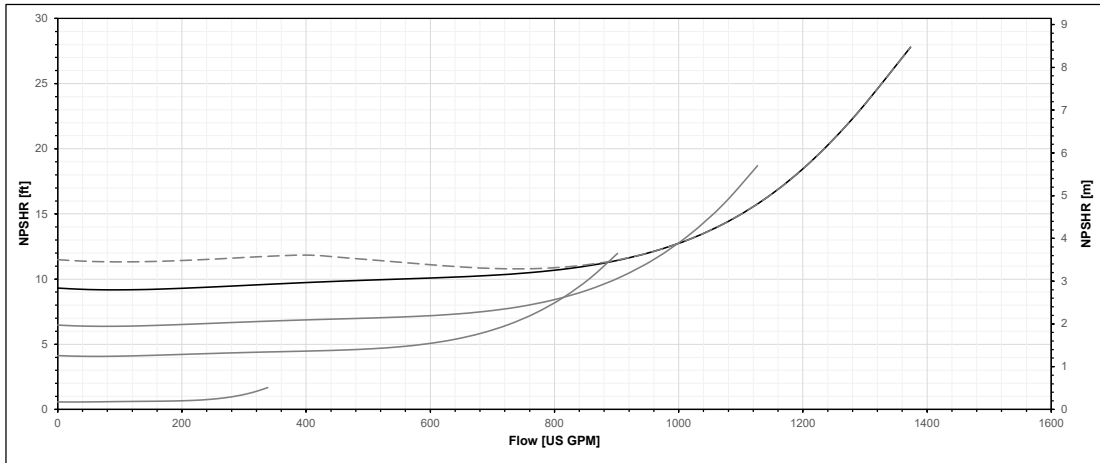
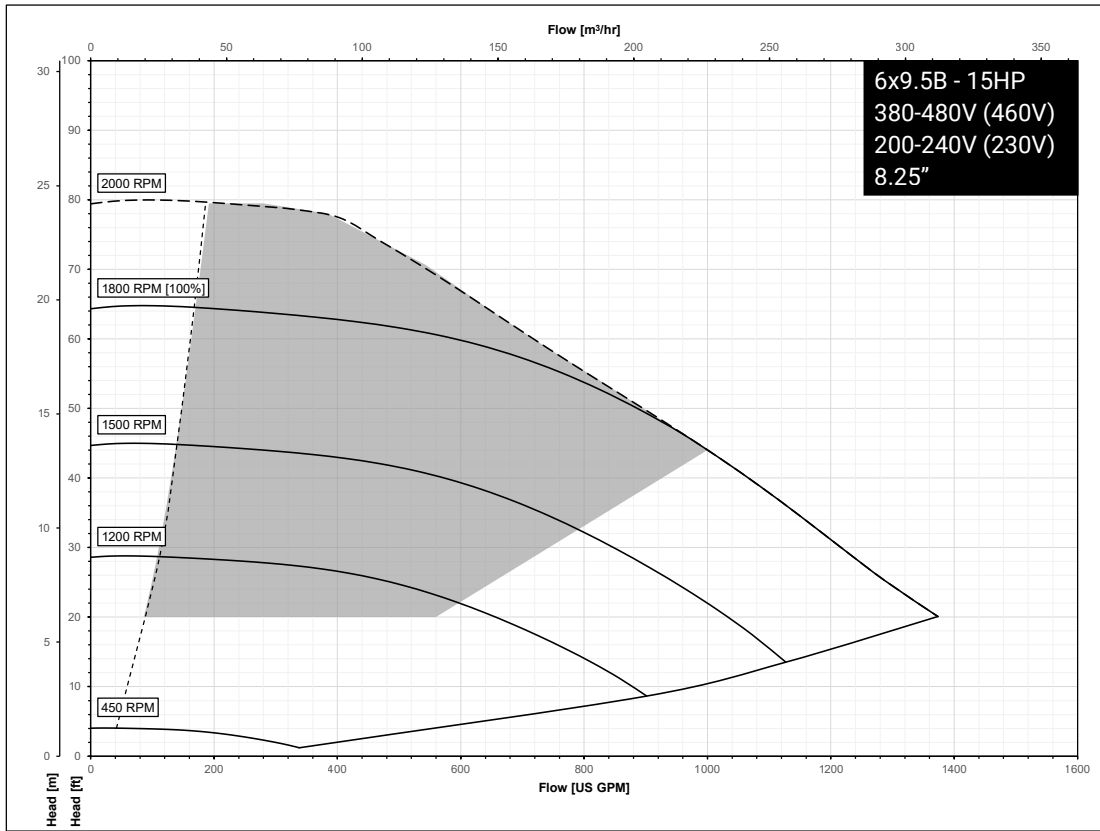

## Materials of construction

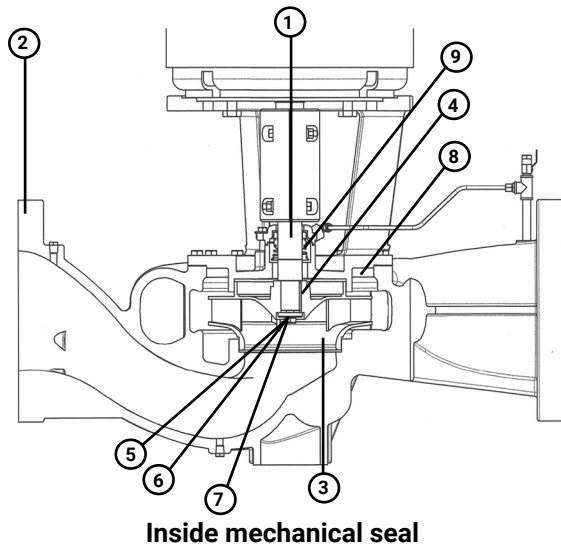

#	Description	Material
1	Shaft	416 stainless steel
2	Volute	Cast Iron ASTM A48 Class B
3	Impeller	ASTM A743 Grade CF8 (304SS)
4	Impeller key	#304 stainless steel
5	Impeller washer	HRPO carbon steel
6	Impeller lock washer	#304 stainless steel
7	Impeller cap screw	#304 stainless steel
8	Volute gasket	Cellulose fiber
9	Seal assemblies	Inside flushed

## Seal assemblies

### Mechanical seal options

Options	EPR/carbon/ceramic	EPR/SiC/SiC
Temperature	-20 to 250 °F (-29 to 121 °C)	-20 to 250 °F (-29 to 121 °C)
pH Limitations	7.0 - 9.0	7.0-12.5
Elastomer	EPR	EPR
Rotating face	Carbon	Silicon carbide
Stationary face	Ceramic	Silicon carbide
Hardware	Stainless steel / brass	Stainless steel
Max glycol/water	50% / 50%	60% / 40%

# Series e-80SCX – Dimensions and weights

(All dimensions in inches and weights in lbs. Do not use for construction purposes.)

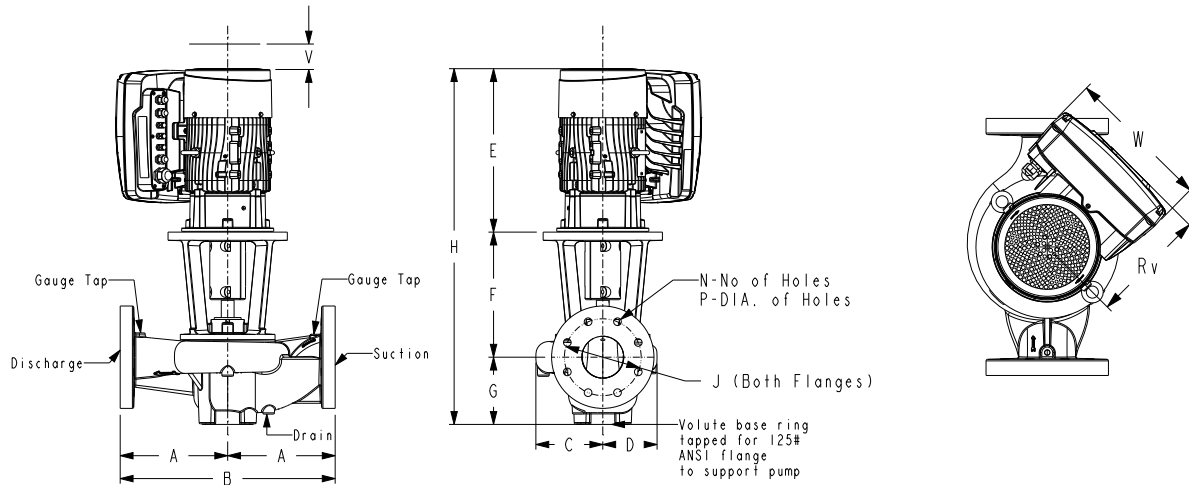

## High speed (800-4000 RPM) 3-phase - 380-480V (460V nominal voltage)

Pump size	Impeller dia. (in.)	NEMA frame	e-80SCX PN	A	B	C	D	E	F	G	H	V	125# ANSI			Rv	W	Gauge Taps (NPT)	Lbs. [kg]
													J	N	P				
1.5x1.5x7C	7	213TC	80SCX157CGMT...	8 [203]	16 [406]	4.57 [116]	4.61 [117]	16.0 [406]	11.75 [298]	4.58 [116]	32.3 [820]	5 [127]	3.88 [99]	4 [102]	0.63 [16]	9.48 [241]	11.89 [302]	0.25	277 [126]
1.5x1.5x7C	6	143TC	80SCX157AEMT...	8 [203]	16 [406]	4.57 [116]	4.61 [117]	13.6 [345]	11.49 [292]	4.58 [116]	29.7 [754]	5 [127]	3.88 [99]	4 [102]	0.63 [16]	7.62 [194]	10.1 [257]	0.25	175 [79]
1.5x1.5x9.5B	9.5	254TC	80SCX159JNMT...	9.5 [241]	19 [483]	5.86 [149]	6.16 [156]	19.3 [490]	11.75 [298]	4.5 [114]	35.6 [904]	6 [152]	3.88 [99]	4 [102]	0.63 [16]	12.17 [309]	14.25 [362]	0.25	284 [129]
1.5x1.5x9.5B	8.5	254TC	80SCX159GHMT...	9.5 [241]	19 [483]	5.86 [149]	6.16 [156]	19.3 [490]	11.75 [298]	4.5 [114]	35.6 [904]	6 [152]	3.88 [99]	4 [102]	0.63 [16]	12.17 [309]	14.25 [362]	0.25	404 [183]
2x2x7B	7	254TC	80SCX207CHMT...	8.5 [216]	17 [432]	4.65 [118]	5.12 [130]	19.3 [490]	11.75 [298]	5.13 [130]	36.2 [919]	6 [152]	4.75 [121]	4 [102]	0.75 [19]	12.17 [309]	14.25 [362]	0.25	509 [231]
2x2x7B	6	213TC	80SCX207AFMT...	8.5 [216]	17 [432]	4.65 [118]	5.12 [130]	16.0 [406]	11.75 [298]	5.13 [130]	32.9 [836]	5 [127]	4.75 [121]	4 [102]	0.75 [19]	9.48 [241]	11.89 [302]	0.25	317 [144]
2x2x9.5C	8.5	254TC	80SCX209GNMT...	10 [254]	20 [508]	6 [152]	6.5 [165]	19.3 [490]	11.81 [300]	5.38 [137]	36.5 [927]	6 [152]	4.75 [121]	4 [102]	0.75 [19]	12.17 [309]	14.25 [362]	0.25	414 [188]
2.5x2.5x7B	7	254TC	80SCX257CHMT...	9 [229]	18 [457]	4.7 [119]	5.46 [139]	19.3 [490]	11.94 [303]	5.4 [137]	36.0 [936]	6 [152]	5.5 [140]	4 [102]	0.75 [19]	12.17 [309]	14.25 [362]	0.25	544 [247]
2.5x2.5x7B	6	213TC	80SCX257AFMT...	9 [229]	18 [457]	4.7 [119]	5.46 [139]	16.0 [406]	11.94 [303]	5.4 [137]	33.3 [846]	5 [127]	5.5 [140]	4 [102]	0.75 [19]	9.48 [241]	11.89 [302]	0.25	352 [160]
2.5x2.5x9.5C	8	254TC	80SCX259ENMT...	10.75 [273]	21.5 [546]	5.96 [151]	7.06 [179]	19.3 [490]	11.89 [302]	6 [152]	37.2 [945]	6 [152]	5.5 [140]	4 [102]	0.75 [19]	12.17 [309]	14.25 [362]	0.25	539 [244]
3x3x7C	7	254TC	80SCX307CNMT...	9.5 [241]	19 [483]	4.98 [126]	6.25 [159]	19.3 [490]	12.00 [305]	5.85 [149]	37.2 [945]	6 [152]	6 [152]	4 [102]	0.75 [19]	12.17 [309]	14.25 [362]	0.25	399 [181]
3x3x7C	5.5	213TC	80SCX307QGMT...	9.5 [241]	19 [483]	4.98 [126]	6.25 [159]	16.0 [406]	12.00 [305]	5.85 [149]	33.9 [861]	5 [127]	6 [152]	4 [102]	0.75 [19]	9.48 [241]	11.89 [302]	0.25	307 [139]
3x3x9.5C	7.25	254TC	80SCX309DNMT...	11.5 [292]	23 [584]	6.53 [166]	7.4 [188]	19.3 [490]	11.94 [303]	6.13 [156]	37.4 [950]	6 [152]	6 [152]	4 [102]	0.75 [19]	12.17 [309]	14.25 [362]	0.25	334 [151]
4x4x7B	6.5	254TC	80SCX407BNMT...	10.5 [267]	21 [533]	5.28 [134]	6.53 [166]	19.3 [490]	12.19 [310]	6.57 [167]	38.1 [968]	6 [152]	7.5 [191]	8 [203]	0.75 [19]	12.17 [309]	14.25 [362]	0.25	519 [235]
4x4x7B	6	254TC	80SCX407AJMT...	10.5 [267]	21 [533]	5.28 [134]	6.53 [166]	19.3 [490]	12.19 [310]	6.57 [167]	38.1 [968]	6 [152]	7.5 [191]	8 [203]	0.75 [19]	12.17 [309]	14.25 [362]	0.25	554 [251]
5x5x7B	5.5	254TC	80SCX507QNMT...	12 [305]	24 [610]	5.69 [145]	8.31 [211]	19.3 [490]	12.63 [321]	7.28 [185]	39.2 [996]	6 [152]	8.5 [216]	8 [203]	0.88 [22]	12.17 [309]	14.25 [362]	0.25	494 [224]
6x6x7B	5.5	254TC	80SCX607QNMT...	14 [356]	28 [711]	6.5 [165]	8.5 [216]	19.3 [490]	12.94 [329]	8.38 [213]	40.6 [1031]	6 [152]	9.5 [241]	8 [203]	0.88 [22]	12.17 [309]	14.25 [362]	0.25	514 [233]

# Series e-80SCX – Dimensions and weights

(All dimensions in inches and weights in lbs. Do not use for construction purposes.)

## High speed (800-4000 RPM) 3-phase - 200-240V (230V nominal voltage)

Pump size	Impeller dia. (in.)	NEMA frame	e-80SCX PN	A	B	C	D	E	F	G	H	V	125# ANSI			Rv	W	Gauge Taps (NPT)	Lbs. [kg]
													J	N	P				
1.5x1.5x7C	6	213TC	80SCX157AEMS...	8 [203]	16 [406]	4.57 [116]	4.61 [117]	16.0 [406]	11.75 [298]	4.58 [116]	32.3 [820]	5 [127]	3.88 [99]	4 [102]	0.63 [16]	9.48 [241]	11.89 [302]	0.25	332 [151]
1.5x1.5x9.5B	8.5	254TC	80SCX159GHMS...	9.5 [241]	19 [483]	5.86 [149]	6.16 [156]	19.3 [490]	11.75 [298]	4.5 [114]	35.6 [904]	6 [152]	3.88 [99]	4 [102]	0.63 [16]	12.17 [309]	14.25 [362]	0.25	404 [183]
2x2x7B	7	254TC	80SCX207CHMS...	8.5 [216]	17 [432]	4.65 [118]	5.12 [130]	19.3 [490]	11.75 [298]	5.13 [130]	36.2 [919]	6 [152]	4.75 [121]	4 [102]	0.75 [19]	12.17 [309]	14.25 [362]	0.25	509 [231]
2x2x9.5C	7.25	254TC	80SCX209DHMS...	10 [254]	20 [508]	6 [152]	6.5 [165]	19.3 [490]	11.81 [300]	5.38 [137]	36.5 [927]	6 [152]	4.75 [121]	4 [102]	0.75 [19]	12.17 [309]	14.25 [362]	0.25	534 [242]
2.5x2.5x7B	7	254TC	80SCX257CHMS...	9 [229]	18 [457]	4.7 [119]	5.46 [139]	19.3 [490]	11.94 [303]	5.4 [137]	36.6 [930]	6 [152]	5.5 [140]	4 [102]	0.75 [19]	12.17 [309]	14.25 [362]	0.25	544 [247]
3x3x7C	6.5	254TC	80SCX307BHMS...	9.5 [241]	19 [483]	4.98 [126]	6.25 [159]	19.3 [490]	12.00 [305]	5.85 [149]	37.2 [945]	6 [152]	6 [152]	4 [102]	0.75 [19]	12.17 [309]	14.25 [362]	0.25	519 [235]
3x3x7C	5.5	254TC	80SCX307QGMS...	9.5 [241]	19 [483]	4.98 [126]	6.25 [159]	19.3 [490]	12.00 [305]	5.85 [149]	37.2 [945]	6 [152]	6 [152]	4 [102]	0.75 [19]	12.17 [309]	14.25 [362]	0.25	519 [235]
4x4x7B	5.75	254TC	80SCX407RHMS...	10.5 [267]	21 [533]	5.28 [134]	6.53 [166]	19.3 [490]	12.19 [310]	6.57 [167]	38.1 [968]	6 [152]	7.5 [191]	8 [203]	0.75 [19]	12.17 [309]	14.25 [362]	0.25	639 [290]
5x5x7B	5	254TC	80SCX507PHMS...	12 [305]	24 [610]	5.69 [145]	8.31 [211]	19.3 [490]	12.63 [321]	7.28 [185]	39.2 [996]	6 [152]	8.5 [216]	8 [203]	0.88 [22]	12.17 [309]	14.25 [362]	0.25	614 [279]

# Series e-80SCX – Dimensions and weights

(All dimensions in inches and weights in lbs. Do not use for construction purposes.)

## Low speed (400-2000 RPM) 3-phase - 380-480V (460V nominal voltage)

Pump size	Impeller dia. (in.)	NEMA frame	e-80SCX PN	A	B	C	D	E	F	G	H	V	125# ANSI			Rv	W	Gauge Taps (NPT)	Lbs. [kg]
													J	N	P				
1.5x1.5x7C	7	143TC	80SCX157CBLT...	8 [203]	16 [406]	4.57 [116]	4.61 [117]	13.6 [345]	11.49 [292]	4.58 [116]	29.7 [754]	5 [127]	3.88 [99]	4 [102]	0.63 [16]	7.62 [194]	10.1 [257]	0.25	210 [95]
1.5x1.5x9.5B	9.5	213TC	80SCX159JDLT...	9.5 [241]	19 [483]	5.86 [149]	6.16 [156]	16.0 [406]	11.75 [298]	4.5 [114]	32.3 [820]	5 [127]	3.88 [99]	4 [102]	0.63 [16]	9.48 [241]	11.89 [302]	0.25	377 [171]
1.5x1.5x9.5B	8.5	143TC	80SCX159GBLT...	9.5 [241]	19 [483]	5.86 [149]	6.16 [156]	13.6 [345]	11.53 [293]	4.5 [114]	29.6 [752]	5 [127]	3.88 [99]	4 [102]	0.63 [16]	7.62 [194]	10.1 [257]	0.25	220 [100]
2x2x7B	7	143TC	80SCX207CBLT...	8.5 [216]	17 [432]	4.65 [118]	5.12 [130]	13.6 [345]	11.54 [293]	5.13 [130]	30.3 [770]	5 [127]	4.75 [121]	4 [102]	0.75 [19]	7.62 [194]	10.1 [257]	0.25	210 [95]
2x2x9.5C	9.5	213TC	80SCX209JELT...	10 [254]	20 [508]	6 [152]	6.5 [165]	16.0 [406]	11.81 [300]	5.38 [137]	33.2 [843]	5 [127]	4.75 [121]	4 [102]	0.75 [19]	9.48 [241]	11.89 [302]	0.25	302 [137]
2x2x9.5C	8	143TC	80SCX209EBLT...	10 [254]	20 [508]	6 [152]	6.5 [165]	13.6 [345]	11.55 [293]	5.38 [137]	30.5 [775]	5 [127]	4.75 [121]	4 [102]	0.75 [19]	7.62 [194]	10.1 [257]	0.25	210 [95]
2.5x2.5x7B	7	143TC	80SCX257CBLT...	9 [229]	18 [457]	4.7 [119]	5.46 [139]	13.6 [345]	11.66 [296]	5.4 [137]	30.7 [780]	5 [127]	5.5 [140]	4 [102]	0.75 [19]	7.62 [194]	10.1 [257]	0.25	210 [95]
2.5x2.5x9.5C	9.5	213TC	80SCX259JELT...	10.75 [273]	21.5 [546]	5.96 [151]	7.06 [179]	16.0 [406]	11.89 [302]	6 [152]	33.9 [861]	5 [127]	5.5 [140]	4 [102]	0.75 [19]	9.48 [241]	11.89 [302]	0.25	332 [151]
2.5x2.5x9.5C	8	213TC	80SCX259EDLT...	10.75 [273]	21.5 [546]	5.96 [151]	7.06 [179]	16.0 [406]	11.89 [302]	6 [152]	33.9 [861]	5 [127]	5.5 [140]	4 [102]	0.75 [19]	9.48 [241]	11.89 [302]	0.25	312 [142]
3x3x7C	7	213TC	80SCX307CCLT...	9.5 [241]	19 [483]	4.98 [126]	6.25 [159]	16.0 [406]	12.00 [305]	5.85 [149]	33.9 [861]	5 [127]	6 [152]	4 [102]	0.75 [19]	9.48 [241]	11.89 [302]	0.25	347 [157]
3x3x9.5C	9.5	254TC	80SCX309JFLT...	11.5 [292]	23 [584]	6.53 [166]	7.4 [188]	19.3 [490]	11.94 [303]	6.13 [156]	37.4 [950]	6 [152]	6 [152]	4 [102]	0.75 [19]	12.17 [309]	14.25 [362]	0.25	429 [195]
3x3x9.5C	8.5	213TC	80SCX309GELT...	11.5 [292]	23 [584]	6.53 [166]	7.4 [188]	16.0 [406]	11.94 [303]	6.13 [156]	34.1 [866]	5 [127]	6 [152]	4 [102]	0.75 [19]	9.48 [241]	11.89 [302]	0.25	357 [162]
3x3x11B	11	254TC	80SCX301LGLT...	12 [305]	24 [610]	6.99 [178]	7.13 [181]	19.3 [490]	11.25 [286]	6.75 [171]	37.3 [947]	6 [152]	6 [152]	4 [102]	0.75 [19]	12.17 [309]	14.25 [362]	0.25	434 [197]
3x3x11B	10.5	254TC	80SCX301KFLT...	12 [305]	24 [610]	6.99 [178]	7.13 [181]	19.3 [490]	11.25 [286]	6.75 [171]	37.3 [947]	6 [152]	6 [152]	4 [102]	0.75 [19]	12.17 [309]	14.25 [362]	0.25	479 [217]
4x4x7B	7	213TC	80SCX407CDLT...	10.5 [267]	21 [533]	5.28 [134]	6.53 [166]	16.0 [406]	12.19 [310]	6.57 [167]	34.8 [884]	5 [127]	7.5 [191]	8 [203]	0.75 [19]	9.48 [241]	11.89 [302]	0.25	302 [137]
4x4x9.5B	9.5	254TC	80SCX409JGLT...	12.5 [318]	25 [635]	6.51 [165]	7.94 [202]	19.3 [490]	12.75 [324]	7.25 [184]	39.3 [998]	6 [152]	7.5 [191]	8 [203]	0.75 [19]	12.17 [309]	14.25 [362]	0.25	554 [251]
4x4x9.5B	8.5	254TC	80SCX409GFLT...	12.5 [318]	25 [635]	6.51 [165]	7.94 [202]	19.3 [490]	12.75 [324]	7.25 [184]	39.3 [998]	6 [152]	7.5 [191]	8 [203]	0.75 [19]	12.17 [309]	14.25 [362]	0.25	599 [272]
4x4x11	10.5	254TC	80SCX401KGLT...	13 [330]	26 [660]	7.01 [178]	8.22 [209]	19.3 [490]	11.44 [291]	7.5 [191]	38.2 [970]	6 [152]	7.5 [191]	8 [203]	0.75 [19]	12.17 [309]	14.25 [362]	0.25	589 [267]
5x5x7B	7	213TC	80SCX507CELT...	12 [305]	24 [610]	5.69 [145]	8.31 [211]	16.0 [406]	12.63 [321]	7.28 [185]	35.9 [912]	5 [127]	8.5 [216]	8 [203]	0.88 [22]	9.48 [241]	11.89 [302]	0.25	502 [228]
5x5x7B	6	213TC	80SCX507ADLT...	12 [305]	24 [610]	5.69 [145]	8.31 [211]	16.0 [406]	12.63 [321]	7.28 [185]	35.9 [912]	5 [127]	8.5 [216]	8 [203]	0.88 [22]	9.48 [241]	11.89 [302]	0.25	482 [219]
5x5x9.5B	9	254TC	80SCX509HGLT...	14.5 [368]	29 [737]	7.02 [178]	9.57 [243]	19.3 [490]	12.25 [311]	7.7 [196]	39.3 [998]	6 [152]	8.5 [216]	8 [203]	0.88 [22]	12.17 [309]	14.25 [362]	0.25	414 [188]
6x6x7B	7	254TC	80SCX607CFLT...	14 [356]	28 [711]	6.5 [165]	8.5 [216]	19.3 [490]	12.94 [329]	8.38 [213]	40.6 [1031]	6 [152]	9.5 [241]	8 [203]	0.88 [22]	12.17 [309]	14.25 [362]	0.25	609 [276]
6x6x7B	6.75	213TC	80SCX607MELT...	14 [356]	28 [711]	6.5 [165]	8.5 [216]	16.0 [406]	12.94 [329]	8.38 [213]	37.3 [948]	6 [152]	9.5 [241]	8 [203]	0.88 [22]	9.48 [241]	11.89 [302]	0.25	477 [216]
6x6x9.5B	8.25	254TC	80SCX609FGLT...	16.75 [425]	33.5 [851]	7.57 [192]	10.67 [271]	19.3 [490]	12.56 [319]	8.88 [226]	40.7 [1034]	6 [152]	9.5 [241]	8 [203]	0.88 [22]	12.17 [309]	14.25 [362]	0.25	554 [251]

# Series e-80SCX – Dimensions and weights

(All dimensions in inches and weights in lbs. Do not use for construction purposes.)

## Low speed (400-2000 RPM) 3-phase - 200-240V (230V nominal voltage)

Pump size	Impeller dia. (in.)	NEMA frame	e-80SCX PN	A	B	C	D	E	F	G	H	V	125# ANSI			Rv	W	Gauge Taps (NPT)	Lbs. [kg]
													J	N	P				
1.5x1.5x7C	7	143TC	80SCX157CBL...	8 [203]	16 [406]	4.57 [116]	4.61 [117]	13.6 [345]	11.49 [292]	4.58 [116]	29.7 [754]	5 [127]	3.88 [99]	4 [102]	0.63 [16]	7.62 [194]	10.1 [257]	0.25	210 [95]
1.5x1.5x9.5B	9.5	213TC	80SCX159JDLS...	9.5 [241]	19 [483]	5.86 [149]	6.16 [156]	16.0 [406]	11.75 [298]	4.5 [114]	32.3 [820]	5 [127]	3.88 [99]	4 [102]	0.63 [16]	9.48 [241]	11.89 [302]	0.25	377 [171]
1.5x1.5x9.5B	8.5	143TC	80SCX159GBLS...	9.5 [241]	19 [483]	5.86 [149]	6.16 [156]	13.6 [345]	11.53 [293]	4.5 [114]	29.6 [752]	5 [127]	3.88 [99]	4 [102]	0.63 [16]	7.62 [194]	10.1 [257]	0.25	220 [100]
2x2x7B	7	143TC	80SCX207CBL...	8.5 [216]	17 [432]	4.65 [118]	5.12 [130]	13.6 [345]	11.54 [293]	5.13 [130]	30.3 [770]	5 [127]	4.75 [121]	4 [102]	0.75 [19]	7.62 [194]	10.1 [257]	0.25	210 [95]
2x2x9.5C	9.5	213TC	80SCX209JELS...	10 [254]	20 [508]	6 [152]	6.5 [165]	16.0 [406]	11.81 [300]	5.38 [137]	33.2 [843]	5 [127]	4.75 [121]	4 [102]	0.75 [19]	9.48 [241]	11.89 [302]	0.25	302 [137]
2x2x9.5C	8	143TC	80SCX209EBL...	10 [254]	20 [508]	6 [152]	6.5 [165]	13.6 [345]	11.55 [293]	5.38 [137]	30.5 [775]	5 [127]	4.75 [121]	4 [102]	0.75 [19]	7.62 [194]	10.1 [257]	0.25	210 [95]
2.5x2.5x7B	7	143TC	80SCX257CBL...	9 [229]	18 [457]	4.7 [119]	5.46 [139]	13.6 [345]	11.66 [296]	5.4 [137]	30.7 [780]	5 [127]	5.5 [140]	4 [102]	0.75 [19]	7.62 [194]	10.1 [257]	0.25	210 [95]
2.5x2.5x9.5C	9.5	213TC	80SCX259JELS...	10.75 [273]	21.5 [546]	5.96 [151]	7.06 [179]	16.0 [406]	11.89 [302]	6 [152]	33.9 [861]	5 [127]	5.5 [140]	4 [102]	0.75 [19]	9.48 [241]	11.89 [302]	0.25	332 [151]
2.5x2.5x9.5C	8	213TC	80SCX259EDLS...	10.75 [273]	21.5 [546]	5.96 [151]	7.06 [179]	16.0 [406]	11.89 [302]	6 [152]	33.9 [861]	5 [127]	5.5 [140]	4 [102]	0.75 [19]	9.48 [241]	11.89 [302]	0.25	312 [142]
3x3x7C	7	213TC	80SCX307CCLS...	9.5 [241]	19 [483]	4.98 [126]	6.25 [159]	16.0 [406]	12.00 [305]	5.85 [149]	33.9 [861]	5 [127]	6 [152]	4 [102]	0.75 [19]	9.48 [241]	11.89 [302]	0.25	347 [157]
3x3x9.5C	9.5	254TC	80SCX309JFLS...	11.5 [292]	23 [584]	6.53 [166]	7.4 [188]	19.3 [490]	11.94 [303]	6.13 [156]	37.4 [950]	6 [152]	6 [152]	4 [102]	0.75 [19]	12.17 [309]	14.25 [362]	0.25	429 [195]
3x3x9.5C	8.5	213TC	80SCX309GELS...	11.5 [292]	23 [584]	6.53 [166]	7.4 [188]	16.0 [406]	11.94 [303]	6.13 [156]	34.1 [866]	5 [127]	6 [152]	4 [102]	0.75 [19]	9.48 [241]	11.89 [302]	0.25	357 [162]
3x3x11B	11	254TC	80SCX301LGLS...	12 [305]	24 [610]	6.99 [178]	7.13 [181]	19.3 [490]	11.25 [286]	6.75 [171]	37.3 [947]	6 [152]	6 [152]	4 [102]	0.75 [19]	12.17 [309]	14.25 [362]	0.25	434 [197]
3x3x11B	10.5	254TC	80SCX301KFLS...	12 [305]	24 [610]	6.99 [178]	7.13 [181]	19.3 [490]	11.25 [286]	6.75 [171]	37.3 [947]	6 [152]	6 [152]	4 [102]	0.75 [19]	12.17 [309]	14.25 [362]	0.25	479 [217]
4x4x7B	7	213TC	80SCX407CDLS...	10.5 [267]	21 [533]	5.28 [134]	6.53 [166]	16.0 [406]	12.19 [310]	6.57 [167]	34.8 [884]	5 [127]	7.5 [191]	8 [203]	0.75 [19]	9.48 [241]	11.89 [302]	0.25	302 [137]
4x4x9.5B	9.5	254TC	80SCX409JGLS...	12.5 [318]	25 [635]	6.51 [165]	7.94 [202]	19.3 [490]	12.75 [324]	7.25 [184]	39.3 [998]	6 [152]	7.5 [191]	8 [203]	0.75 [19]	12.17 [309]	14.25 [362]	0.25	554 [251]
4x4x9.5B	8.5	254TC	80SCX409GFLS...	12.5 [318]	25 [635]	6.51 [165]	7.94 [202]	19.3 [490]	12.75 [324]	7.25 [184]	39.3 [998]	6 [152]	7.5 [191]	8 [203]	0.75 [19]	12.17 [309]	14.25 [362]	0.25	599 [272]
4x4x11	10.5	254TC	80SCX401KGLS...	13 [330]	26 [660]	7.01 [178]	8.22 [209]	19.3 [490]	11.44 [291]	7.5 [191]	38.2 [970]	6 [152]	7.5 [191]	8 [203]	0.75 [19]	12.17 [309]	14.25 [362]	0.25	589 [267]
5x5x7B	7	213TC	80SCX507CELS...	12 [305]	24 [610]	5.69 [145]	8.31 [211]	16.0 [406]	12.63 [321]	7.28 [185]	35.9 [912]	5 [127]	8.5 [216]	8 [203]	0.88 [22]	9.48 [241]	11.89 [302]	0.25	502 [228]
5x5x7B	6	213TC	80SCX507ADLS...	12 [305]	24 [610]	5.69 [145]	8.31 [211]	16.0 [406]	12.63 [321]	7.28 [185]	35.9 [912]	5 [127]	8.5 [216]	8 [203]	0.88 [22]	9.48 [241]	11.89 [302]	0.25	482 [219]
5x5x9.5B	9	254TC	80SCX509HGLS...	14.5 [368]	29 [737]	7.02 [178]	9.57 [243]	19.3 [490]	12.25 [311]	7.7 [196]	39.3 [998]	6 [152]	8.5 [216]	8 [203]	0.88 [22]	12.17 [309]	14.25 [362]	0.25	414 [188]
6x6x7B	7	254TC	80SCX607CFLS...	14 [356]	28 [711]	6.5 [165]	8.5 [216]	19.3 [490]	12.94 [329]	8.38 [213]	40.6 [1031]	6 [152]	9.5 [241]	8 [203]	0.88 [22]	12.17 [309]	14.25 [362]	0.25	609 [276]
6x6x7B	6.75	213TC	80SCX607MELS...	14 [356]	28 [711]	6.5 [165]	8.5 [216]	16.0 [406]	12.94 [329]	8.38 [213]	37.3 [948]	6 [152]	9.5 [241]	8 [203]	0.88 [22]	9.48 [241]	11.89 [302]	0.25	477 [216]
6x6x9.5B	8.25	254TC	80SCX609FGLS...	16.75 [425]	33.5 [851]	7.57 [192]	10.67 [271]	19.3 [490]	12.56 [319]	8.88 [226]	40.7 [1034]	6 [152]	9.5 [241]	8 [203]	0.88 [22]	12.17 [309]	14.25 [362]	0.25	554 [251]





Learn more about  
**e-80X/e-80SCX Smart Pumps**

### **Xylem Product Cybersecurity:**

Xylem values your system security and the availability of your critical services. For more information on Xylem cybersecurity practices or to contact the cybersecurity team please visit [xylem.com/security](http://xylem.com/security).

**Xylem Inc.**  
8200 N. Austin Avenue  
Morton Grove, Illinois 60053

Phone: (847) 966-3700  
Fax: (847) 965-8379  
[www.xylem.com/bellgossett](http://www.xylem.com/bellgossett)

Subject to change without notice. All information presented herein is believed reliable and in accordance with accepted engineering practices. Xylem makes no warranties as to the completeness of this information. Users are responsible for evaluating individual product suitability for specific applications. Xylem assumes no liability whatsoever for any special, indirect or consequential damages arising from the sale, resale or misuse of its products.

© 2025 Xylem, Bell & Gossett and Hydrovar are registered trademarks of Xylem Inc. or one of its subsidiaries. MODBUS is a registered trademark of Schneider Electric USA, Inc. The Bluetooth word mark and logos are registered trademarks owned by Bluetooth SIG, Inc. and any use of such marks by Xylem Inc. or one of its subsidiaries is under license. All other trademarks or registered trademarks are the property of their respective owners.