

# Design Recommendations

FOR PUMP STATIONS USING FLYGT CENTRIFUGAL OR AXIAL FLOW PUMPS

# Table of Contents

	<b>INTRODUCTION</b>	<b>04</b>
<b>1</b>	<b>GENERAL CONSIDERATIONS</b>	<b>06</b>
<b>2</b>	<b>PUMP STATION MODEL TESTING</b>	<b>12</b>
<b>3</b>	<b>COMPUTATIONAL MODELING</b>	<b>14</b>
	A   CFD and Pump Station Design	15
	B   Corrective Measures	16
<b>4</b>	<b>RECOMMENDATIONS FOR CENTRIFUGAL PUMP STATIONS</b>	<b>18</b>
	A   Required Volumes	19
	B   Net Positive Suction - NPSH	22
	C   The Flygt TOP station concept	24
	D   Importance of the Duty Point	25
	E   Horizontal and vertical dry installation of Flygt pumps	26
	F   Systems Engineering	27
	G   Additional Services	27
<b>5</b>	<b>CENTRIFUGAL PUMP STATION DESIGNS</b>	<b>28</b>
	A   Small and Midrange Pump Sump Designs	29
	B   Small and Midrange Dry Installed Pump Sump Designs	32
	C   Large Pump Sump Designs	37
<b>6</b>	<b>SPECIAL CONSIDERATIONS FOR DRY INSTALLED CENTRIFUGAL PUMPS</b>	<b>44</b>
	A   Vibration	46
	B   Noise	47
	C   Inlet Conditions	48
	D   Piping Support	52
	E   Soft Installation Alternative	52
	F   The Good Dry Pump Station	54
	G   Effects of Operation on Pump Noise and Vibration	55
	H   Motor Surface Temperature	60
	I   Priming Dry Pit Pumps	61

<b>7</b>	<b>CONCRETE AND ANCHORING RECOMMENDATIONS FOR DRY INSTALLED CENTRIFUGAL PUMPS</b>	<b>62</b>
	A   Concrete Foundations	64
	B   Anchor Recommendations	65
	C   Pump Attachment	66
<b>8</b>	<b>RECOMMENDATIONS FOR AXIAL PUMP STATIONS</b>	<b>68</b>
	A   Flygt Propeller (PI) and Mixed Flow (LI) Pump Introduction	70
	B   General Considerations for Pump Station Design for PL And LL Pumps	71
	C   Zones of Axial Pump Stations	72
	D   Inlet Considerations	73
	E   Pump Bay Design Variations	74
	F   Installation Alternatives	76
	G   Installation Components	78
	H   Cable Protection and Suspension for Tube Installed Pumps	80
	I   Installation of Pumps	81
	J   Flygt Cable Seal Units for Pressurized Tubes (Column)	81
	K   Submergence and Loss Diagrams for PL and LL Pumps	82
<b>9</b>	<b>AXIAL PUMP STATION DESIGNS</b>	<b>92</b>
	A   Propeller Pump Station Designs	93
	B   Mixed Flow Pump Station Designs	98
	C   Ultra-Low Head Propeller Pump Station Design	101

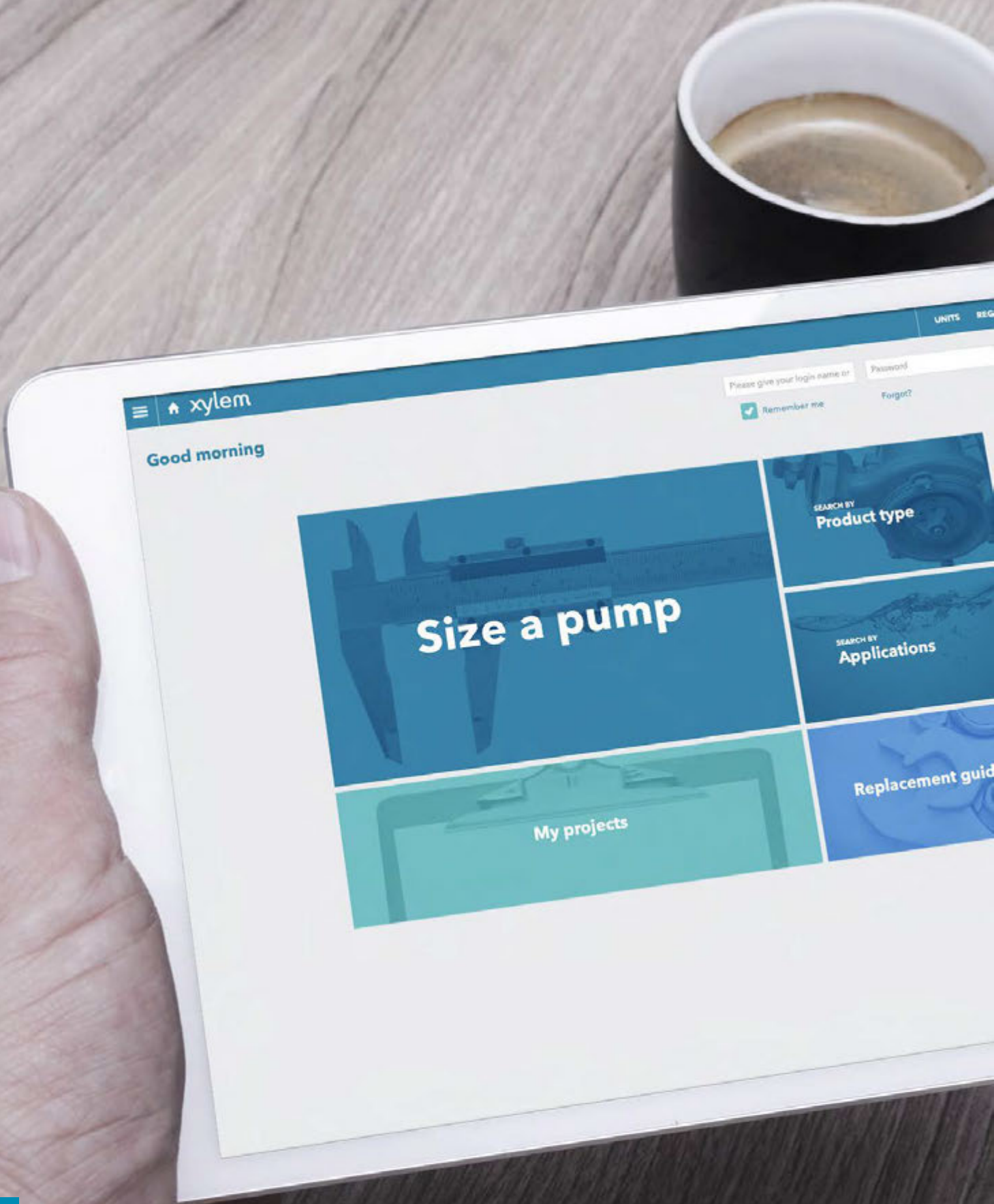

Dear Reader,

This design recommendation manual is intended to guide you to the proper installation of Flygt pumps into various applications and installation methods. It includes both centrifugal and axial flow pumps as well as pumps that are installed submerged or dry.

The station designs in this document have been developed over 40 years of research and study. They have an uncountable number of successful installations around the world and have been proven by use of physical and computational modeling. This means they can be used within the guidelines and limits provided and be ensured of having a successful pump and pump station installation.

This manual can be used by itself to generate a pump station design, but all of the information contained within this guide can also be found in our pump station design software, SECAD. SECAD allows a user to easily generate a pump station based upon our station design guidelines in a few minutes for their own use. If you do not have SECAD, please contact your local Xylem office or representative and ask for assistance.

As every site is unique, we understand that these design guidelines will not work in every location. If you need assistance with your local station design challenge please contact your local Xylem office or representative. We will be glad to apply our vast knowledge of station design to help you with your specific problem and can also assist you with both physical and computational modeling, as described later in the document.

This manual is the first time all of Flygt's station design engineering and expertise has been collected into one place. This allows us to showcase all of the research and development that has been done to help ensure that when you purchase a Xylem pump, you can have a product and installation that is trouble free and also helps save you time and money.

Sincerely,

The Flygt Station Design Team

**Ideally, the flow of fluid into any pump should be uniform, steady, and free from swirl and entrained air.**

## A | GENERAL CONSIDERATIONS

The Flygt standard pump sump designs that are included in these design recommendations can be used as it is, or with appropriate variations to meet the requirements of most installations. If significant change is necessary to the standard designs (more than 10% in size or any of the dimensions), please contact your local Xylem representative for assistance.

There are six adverse hydraulic effects that the standard designs in these design guidelines try to address. These are: excessive pre-swirl, uneven velocity distribution at the pump intake, vortices (surface and submerged), entrained air, sedimentation of solids and floating debris.

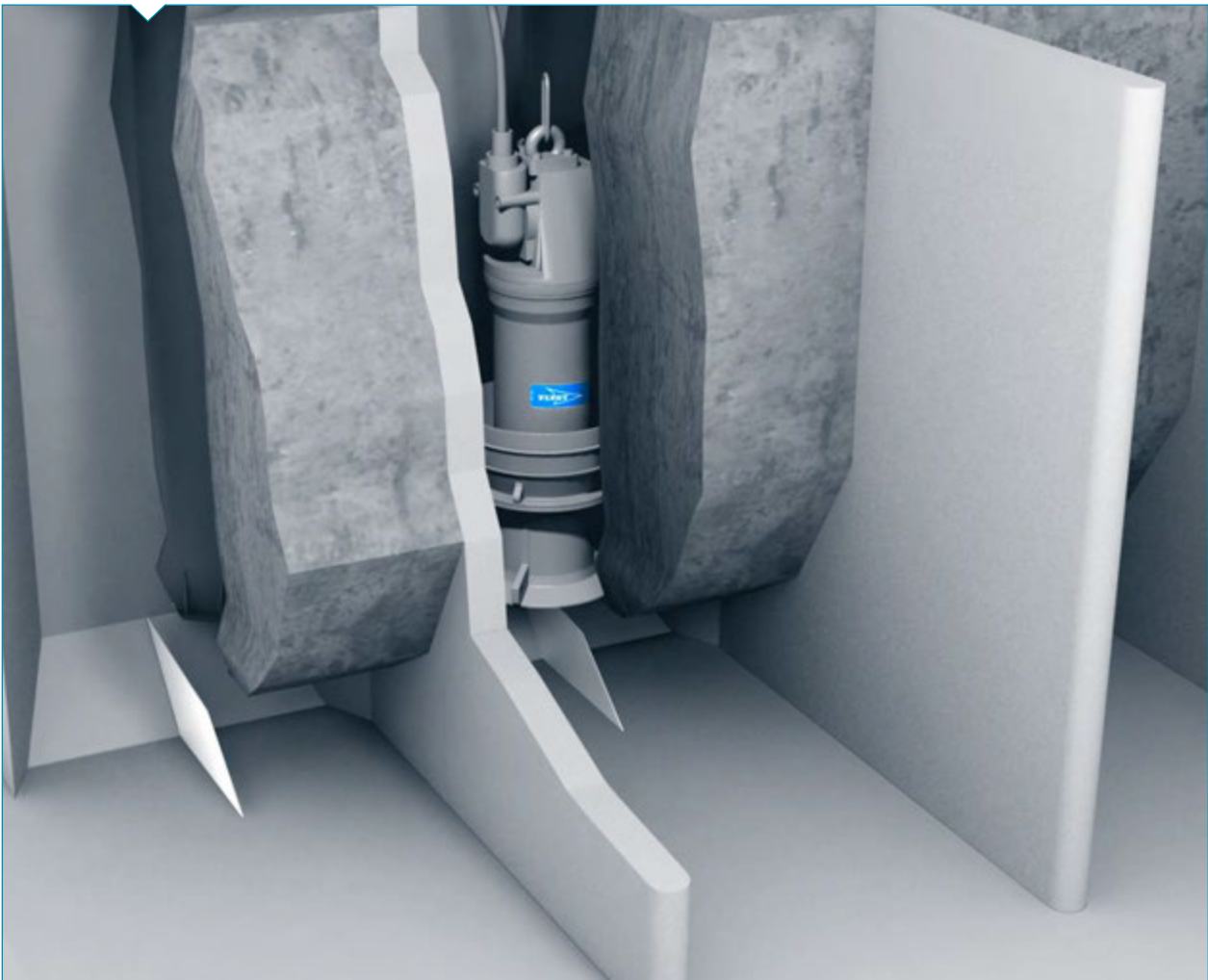

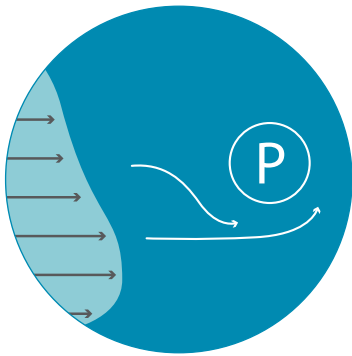

### Excessive Pre-swirl

Can influence efficiency and performance, create cavitation.

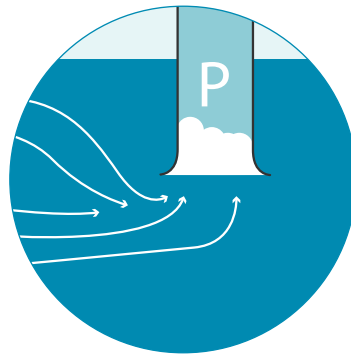

### Uneven Velocity

Distribution at the Pump Intake

Can influence efficiency, create noise and vibration, causing bearing wear and pulsating discharge.

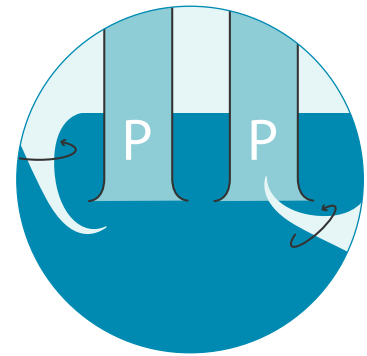

### Vortices

Can lead to cavitation, uneven load noise and vibration.

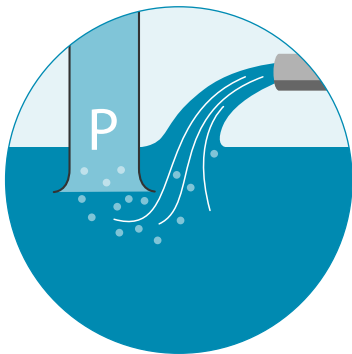

### Entrained Air

Can influence efficiency, create cavitation and lead to corrosion of the impeller and vibration.

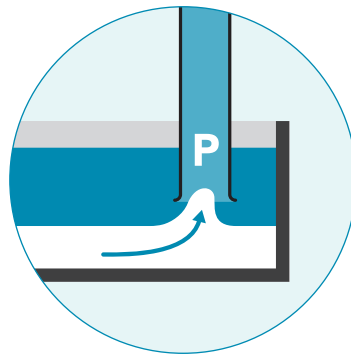

### Sedimentation of Solids

Can influence efficiency, create cavitation and lead to corrosion of the impeller and vibration.

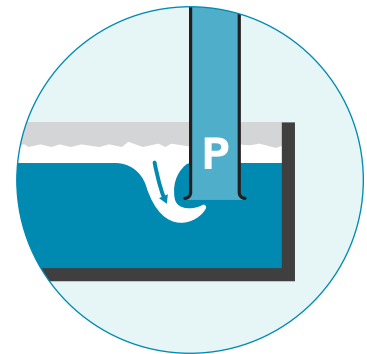

### Floating Debris

Can influence efficiency, create cavitation and lead to corrosion of the impeller and vibration.

Lack of flow uniformity can cause a pump to operate at a lower efficiency. Unsteady flow causes the load on the impeller to fluctuate, which can lead to noise, vibration, bearing and seal problems.

Swirl in a pump intake can cause a significant change in the operating conditions of the pump and produce changes in the flow capacity, power required and overall efficiency of the pump. It can also result in local vortex-type pressure reductions that induce air cores that can extend into the pump. This, and any other air ingestion, can cause reductions in pumped flow and fluctuations on the impeller load, which will result in noise and vibration with consequent physical damage.

These fluctuations can also impact processes in other parts of the system. The design of a sump should not only provide proper approach flow to the pumps, it should also prevent the accumulation of sediments and surface scum in the sump. Both accumulated sediments and floating debris can cause severe sump and pump problems, from the buildup of toxic hydrogen sulfide gas to the clogging of pumps from large pieces of floating debris falling and blocking the pump intake.

It is always good to remember that the pump and pump sump are integral parts of an overall system that includes a variety of other structures and elements, such as ventilation systems and handling equipment. Operating costs can be reduced with the help of effective planning and a suitable operation schedule. Xylem can assist to ensure that the total cost of ownership of a pump station can be reduced as much as possible.



### Consider the following recommendations when designing pump sumps

- | Direct flow of water from the sump entrance toward the pump inlets in such a way that it reaches the inlets with a minimum of swirl and non-uniformity of flow.
- | If there is a concern that surface vortices may form in a pump sump, it is important to try and develop ways to reduce the risk associated with this damaging phenomenon. A properly placed baffle near the inlet to the sump can redirect energy that would normally create swirl and could cause vortex formation (see examples in the later sections of these design recommendations). If no changes are feasible to the sump design, adding water depth is one last possible method to prevent a surface vortex from forming.
- | Although excessive turbulence or large eddies should be avoided, some turbulence helps prevent the formation and growth of vortices.
- | Prevent sediment, which could be foul, from accumulating within the sump. Avoid stagnant regions, or regions of such low velocity where sedimentation might occur. A sloping floor and fillets (also called benching) often helps to prevent sedimentation. For large variations in flow, some parts of the sump should be setup to handle low inflows with a lower floor level and a smaller pump.
- | Surface scum, floating sludge and small debris can accumulate in any relatively calm region of the water surface. Lower the water level as much as possible to increase both the velocity and turbulence and pump this material away. This cleaning cycle will help keep the station clean and should be done manually to ensure that the pump will not ingest air for a prolonged period of time. The increase in flow velocity during a cleaning cycle will also assist in removing possible accumulation of sediment on the floor.
- | When station inflow approaches the wet well at a relatively high elevation, the liquid may fall a significant distance as it enters the sump. Such a drop can also occur whenever the pumps have lowered the liquid level in the sump to the point at which all pumps are about to be switched off. Therefore, the path between the sump entrance and the pump inlets must be long enough for the air to rise to the surface and escape before reaching the pumps. Sufficiently dissipate the energy of falling water to keep excessively high and irregular velocities from occurring within the sump. Accomplish this with properly designed and correctly positioned baffle walls.
- | In general, keep the sump as small and as simple as possible to minimize construction costs. However, a minimum sump volume may be specified for other reasons, such as providing for a minimum retention time, or ensuring that only a certain number of pump starts per hour occur.
- | Whenever a new design departs significantly from standard configurations, consider model tests and a CFD study of the sump.

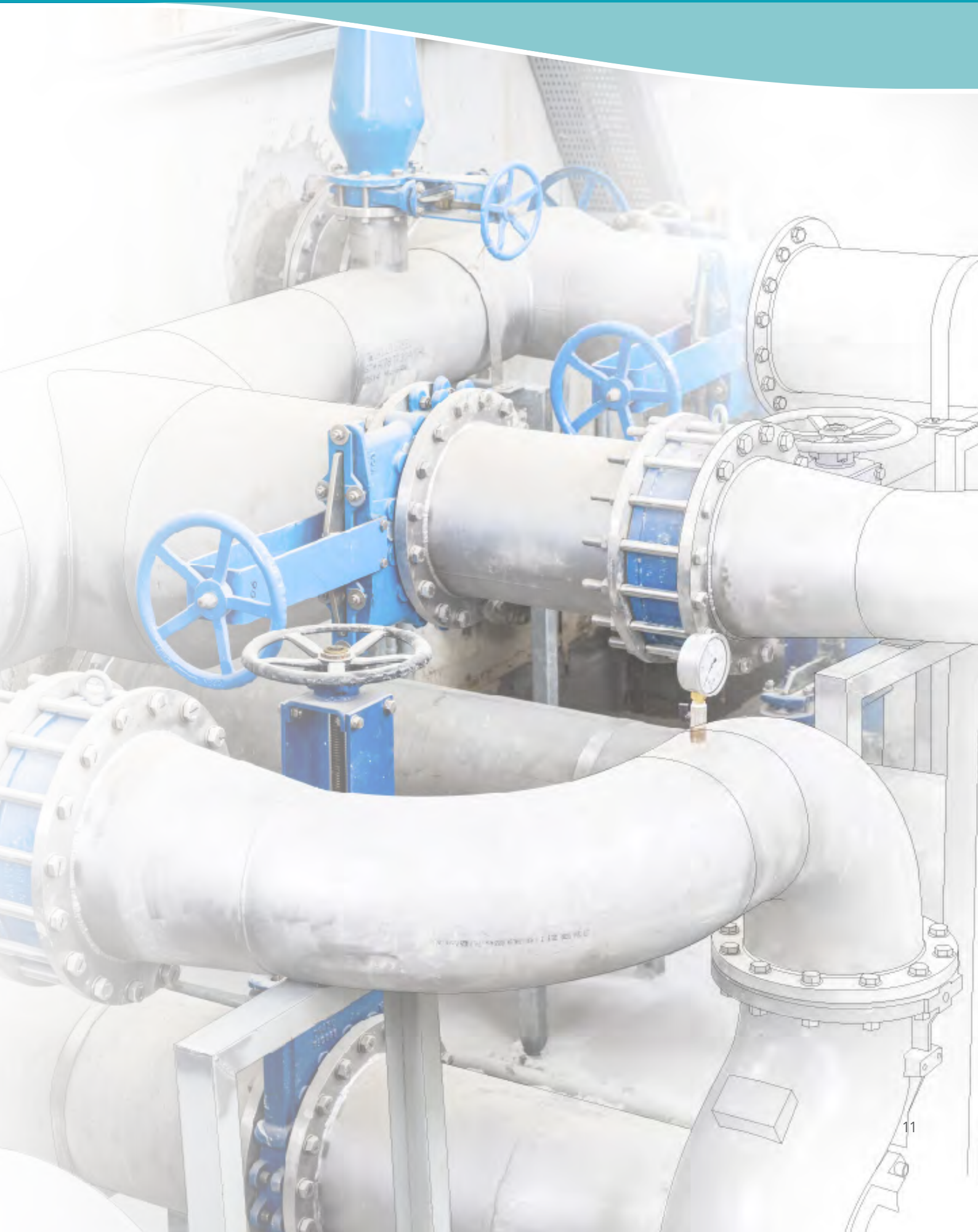

Hydraulic models are often used in the design process of pump stations.

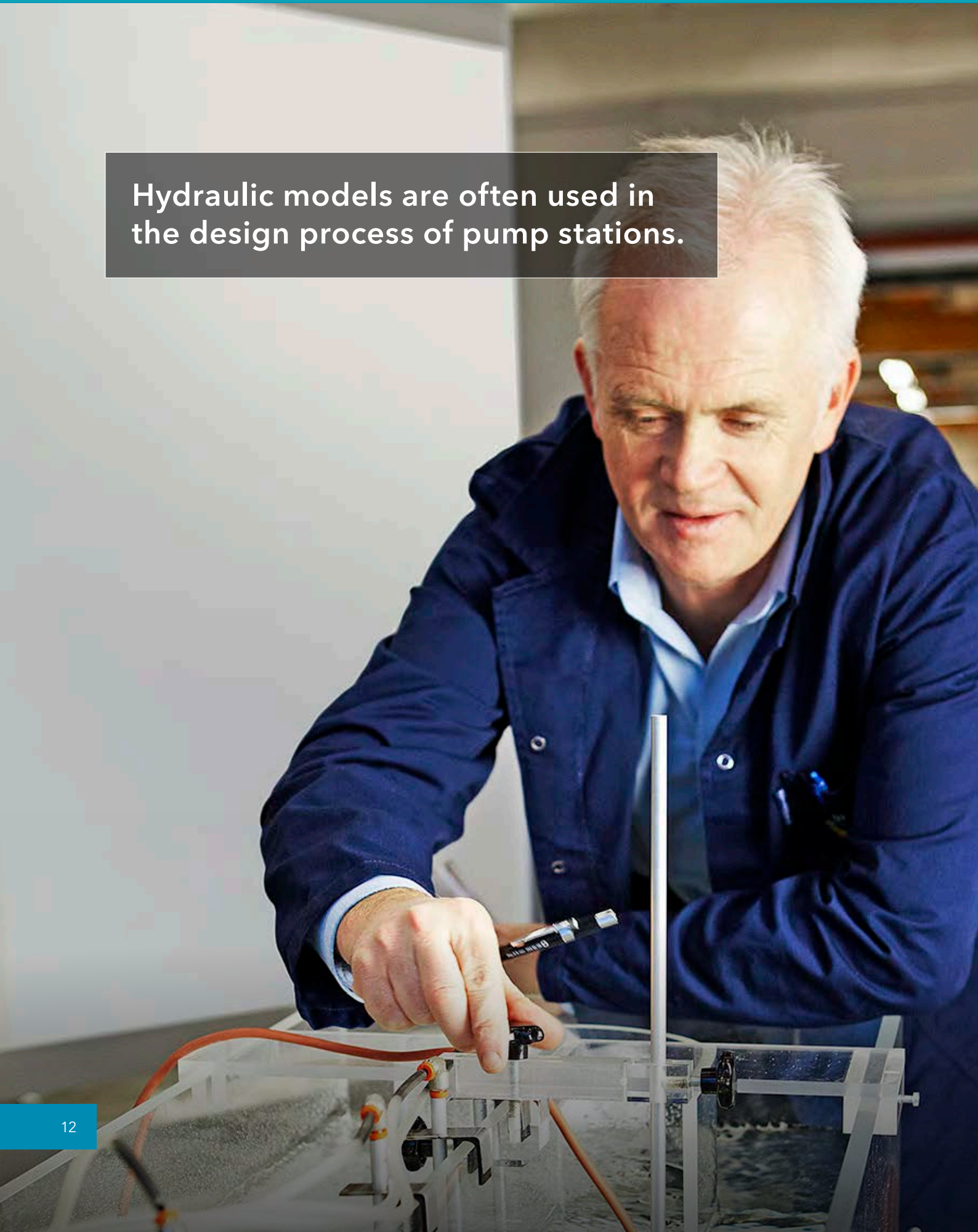

The station design recommendations found in this book have been proven by using hydraulic models.

Hydraulic models are often essential in the design of structures that are used to convey or control the flow distribution. They can provide effective solutions to complex hydraulic problems with unmatched reliability. Their costs are often recovered through improvements in design that are both technically better and less costly. Conduct model testing for a pump station in which the geometry differs from recommended standards, particularly if no prior experience with the application exists. Good engineering practice calls for model tests for all major pump stations if the flow rate per pump exceeds 2.5 m<sup>3</sup>/s, or if multiple pump combinations are used.

**Tests are particularly important if:**

- | Sumps have water levels below the recommended minimum submergence.
- | Sumps have obstructions close to the pumps.
- | Multiple pump sumps require baffles to control the flow distribution.
- | Existing sumps are to be upgraded with significantly greater discharges.

A model of a pump station usually encompasses a representative portion of how the water approaches the station, the inlet structure, the forebay and the pump bays. The discharge portion of the flow is seldom included.

Testing may encompass the following flow features and design characteristics:

**Inlet Structure**

- | Flow distribution, vortex formation, air entrainment, intrusion of sediment and debris.

**Forebay and Pump Bays**

- | Flow distribution, pre-swirl, surface and bottom vortices, and sediment transport.

**Operating Conditions**

- | Pump duty modes, start and stop levels, and pump down procedures.

Model testing can also be employed to seek solutions to problems in existing installations.

If the cause of a problem is unknown, it can be less expensive to diagnose and remedy with model studies compared to trial and error at full scale. The pump manufacturer's involvement is often required in the evaluation of the results of model tests. Experience is required to determine whether the achieved results are satisfactory and will lead to proper overall operation. We can offer guidance regarding the need for model tests and assist in their planning, arrangement and evaluation.

CFD makes it possible to obtain a more efficient method for evaluating station designs through numerical simulation.

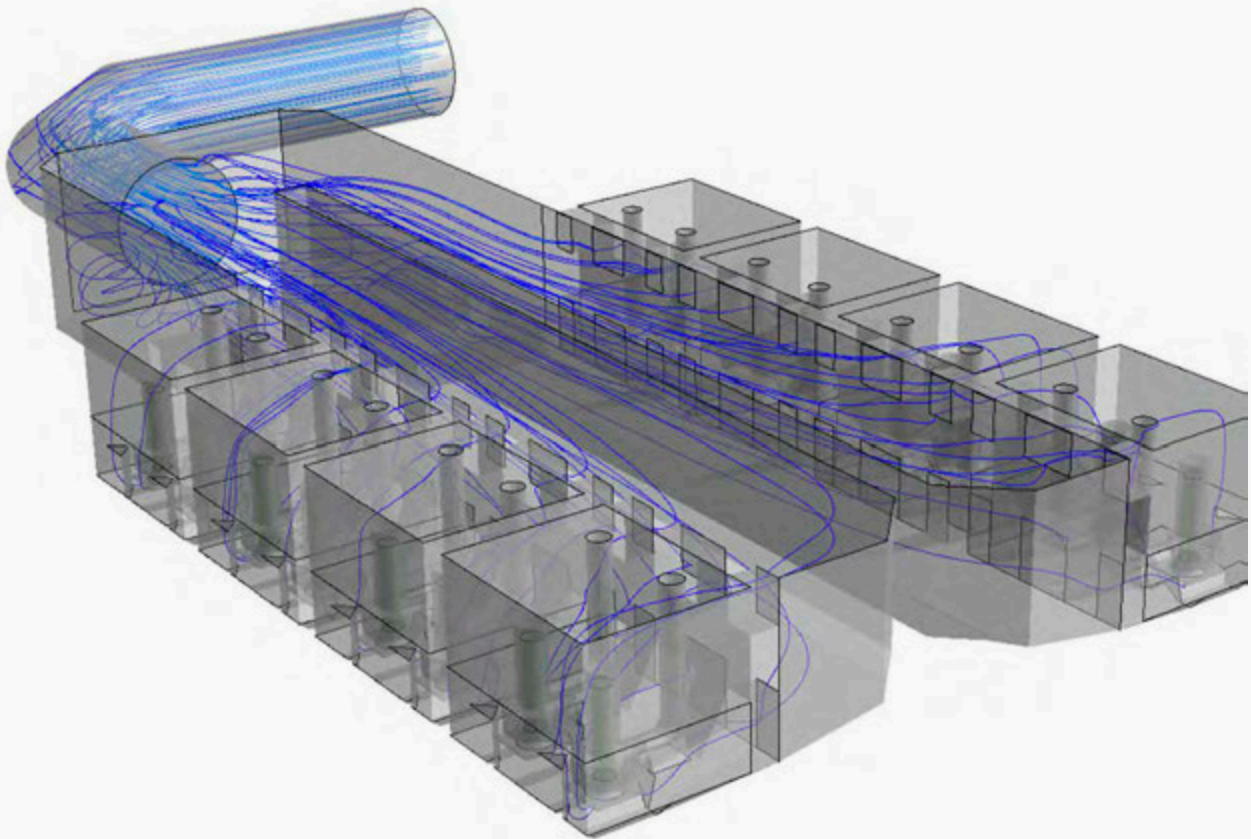

## A | CFD AND PUMP STATION DESIGN

Computational fluid dynamics (CFD) analysis has the potential to provide far more detailed information of the flow field at a fraction of the cost and time needed for the model tests. It has been increasingly accepted as a station design tool, along with Computer-Aided Design (CAD) tools. CFD makes it possible to obtain a more efficient method for evaluating station designs through numerical simulation. It offers increased qualitative and quantitative understanding of pump station hydraulics and can provide good comparisons between various design alternatives.

But CFD does have its limitations. A good example is in situations where multiphase flow characteristics are more predominant, where free surface flow has significant effects or when air entrainment needs to be studied with CFD analysis. Both model tests and CFD have advantages and disadvantages that need to be evaluated for each individual case. With our experience in both model tests and CFD, we can advise on the best solution for a given problem, which may include a combination of the two methods.

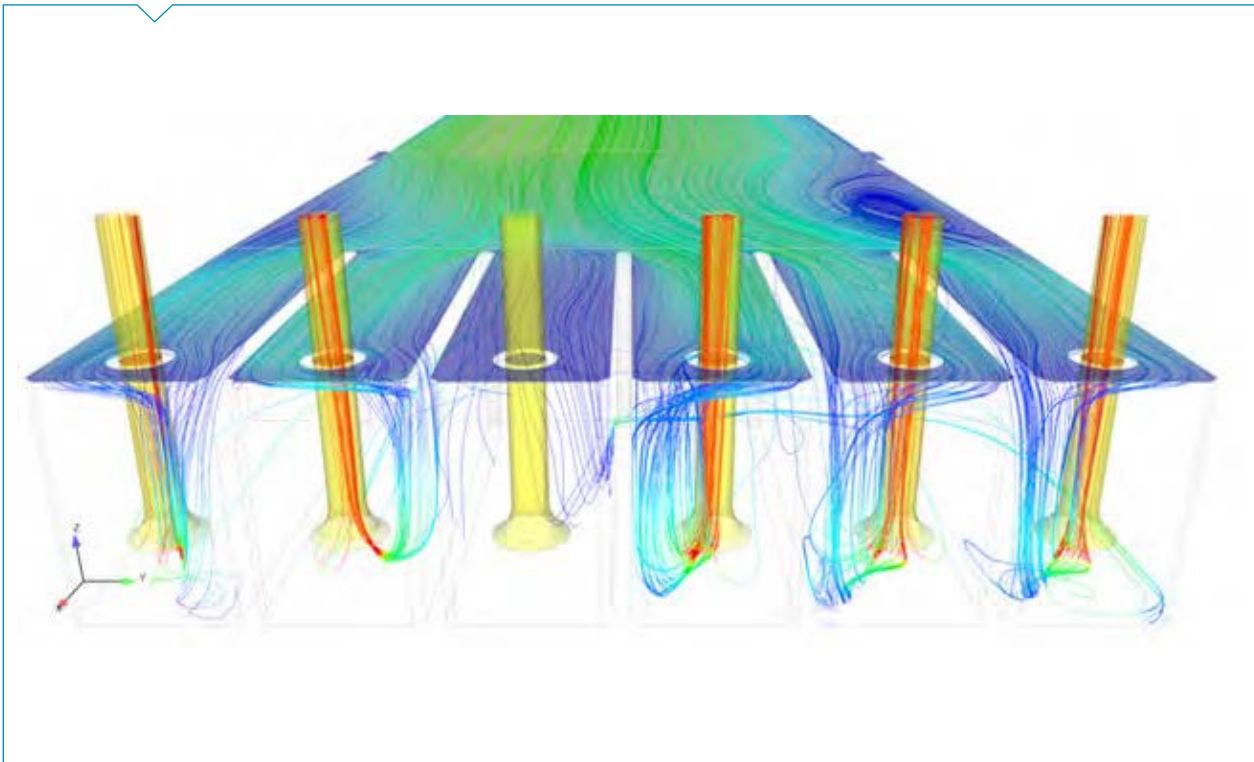

## B | CORRECTIVE MEASURES

The designs described in this manual have been proven to work well in practice. For some applications, however, not all the requirements for a good, simple design can be met. This can be due to limitations of space, installation of new pumps in old stations or difficult approach conditions. Sometimes, for example, it may be impossible to provide adequate submergence so that some vortexing or swirl may occur. In these cases, corrective measures must be taken to eliminate the undesirable features of the flow - particularly those associated with excessive swirl around the pump tube, with air-entraining surface vortices and with submerged vortices. Swirl around the pump tube is usually caused by an asymmetrical velocity distribution in the approach flow. Ways should be sought to improve its symmetry.

Subdivision of the inlet flow with dividing walls can improve its symmetry. Alternative solutions include the introduction of training walls, baffles or varied flow resistance. Reducing flow velocity by increasing the water depth in the sump can also help to minimize the negative effects of an asymmetrical approach.

Relatively small asymmetries of flow in propeller pump stations can be corrected by the insertion of splitter plates between the pump tube and the back wall of the sump, as well as underneath the pump on the floor. These plates block the swirl around the tube and prevent formation of wall vortices.

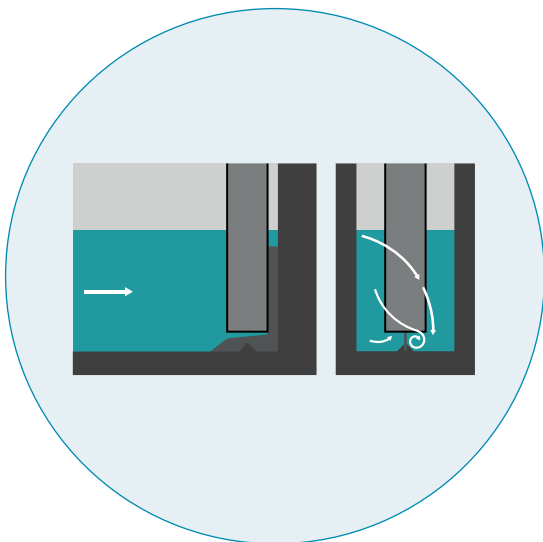

These measures are integral features in most of our standard configurations. Submerged vortices can form almost anywhere on the solid boundary of the sump and they are often difficult to detect on the site. They can, however, be detected much more readily in CFD models and model tests.

The existence of submerged vortices may be revealed by the rough running of the pump, or from erosion of the propeller blades. Eliminate submerged vortices by disturbing the formation of stagnation points in the flow.

## SURFACE BAFFLE FOR VORTEX SUPPRESSION

The flow pattern can be altered, for example, by adding a center cone or a prismatic splitter under the pump, or by inserting fillets and benching between adjoining walls, as in some of our standard configurations.

Air-entraining vortices may form either in the wake of the pump tube or upstream from it. They form in the wake if the inlet velocity is too high, or if the depth of flow is too small. They form upstream if the velocity is too low. In either case, these vortices can be eliminated by introducing extra turbulence into the surface flow (i.e. by placing a transverse beam or baffle at the water surface). Such a beam should enter the water at a depth equal to about one quarter of the tube diameter and be placed about 1.5–2.0 diameters upstream of the tube. A floating beam will be more effective if the water level varies considerably.

In some cases, placing a floating raft - either a plate or a grid - upstream of the tube will eliminate air-entraining vortices. Both forms impede the formation of surface vortices. Alternatively, an inclined plate similar to that shown in the draft tube installation can be used.

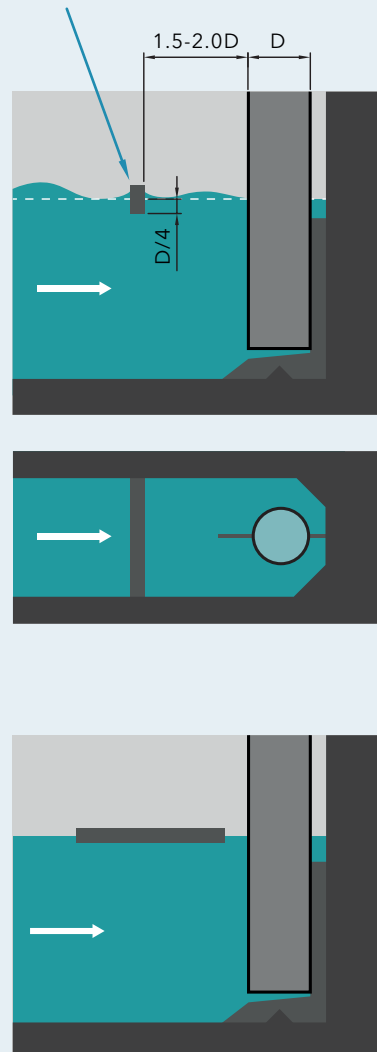

**Design of the sump is crucial for the pump to have a long life. This section covers items for centrifugal Flygt pumps.**



## A | REQUIRED VOLUMES

How often a pump is started depends on the pump capacity, inflow to the sump and the volume between start and stop levels - the "active" or "storage" volume. The real inflow to a pump station will never be constant. It will differ according to the time of the day, the weather and the location of the station within the system.

The required volume will be overestimated if the calculation is based upon the worst case inflow condition for minimizing the number of pump starts. This will also result in long periods of pump inactivity (i.e. at night and in dry weather) and lead to problems as the sediment settles on the sump floor and floating materials accumulate on the surface. The settled sediment may cause clogging at start and noxious gases may build-up. Blockages of this sort are one of the most common causes of emergency call-outs for pump failure.

Reduce the sump volume to increase the starting frequency and resolve this problem. For most Flygt pumps, 15 starts/hour are possible without endangering the life of the pump. Some pumps can handle up to 30 starts/hour without any decrease in the life of the pump.

The increased usage of variable frequency drives (VFDs) has started to change the concept of required volumes. New control strategies are being used with this technology which maintain a constant level in the sump. This strategy no longer works around the idea of active volumes. Also, variable frequency drives act as a "soft-starter", greatly reducing the mechanical stress on a motor during starting. This greatly increases the number of starts per hour a pump can do.

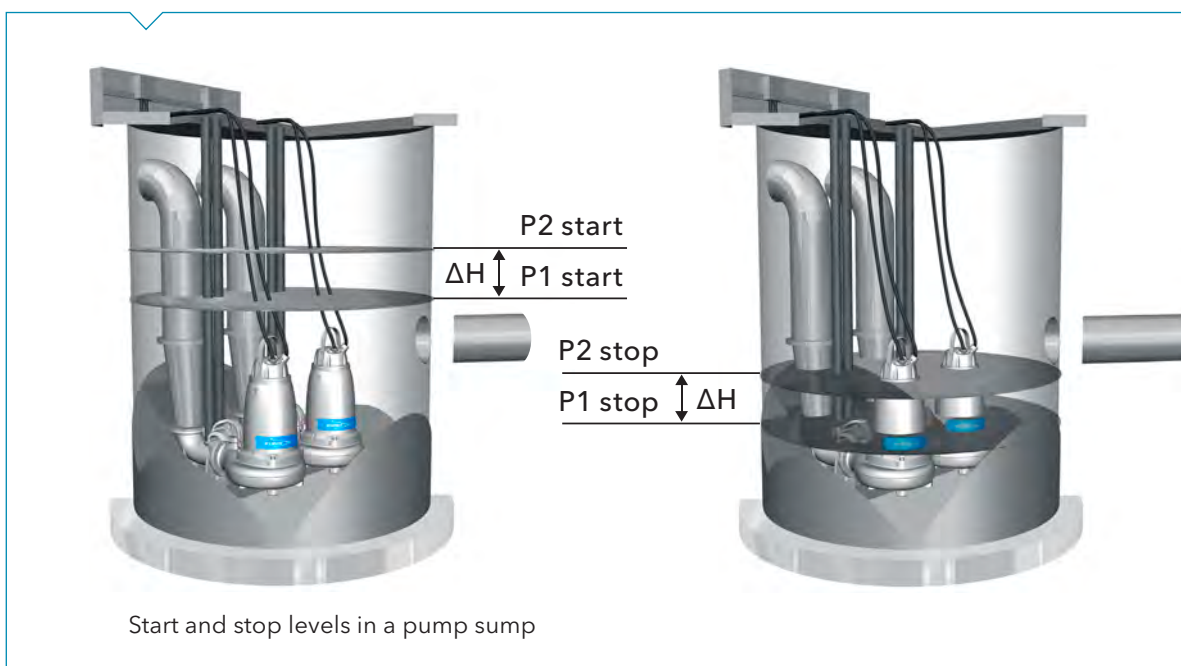

However, as the formula used for the calculation of the active volume is very widespread and familiar, it is unlikely the formulas on the next page will be discontinued in the near future. Due to their conservative nature, the formulas provide a good amount of extra capacity when needed. This extra capacity, which can provide some piece of mind, can also lead to problems as described previously in this section.

### Minimize station volumes with a correct design

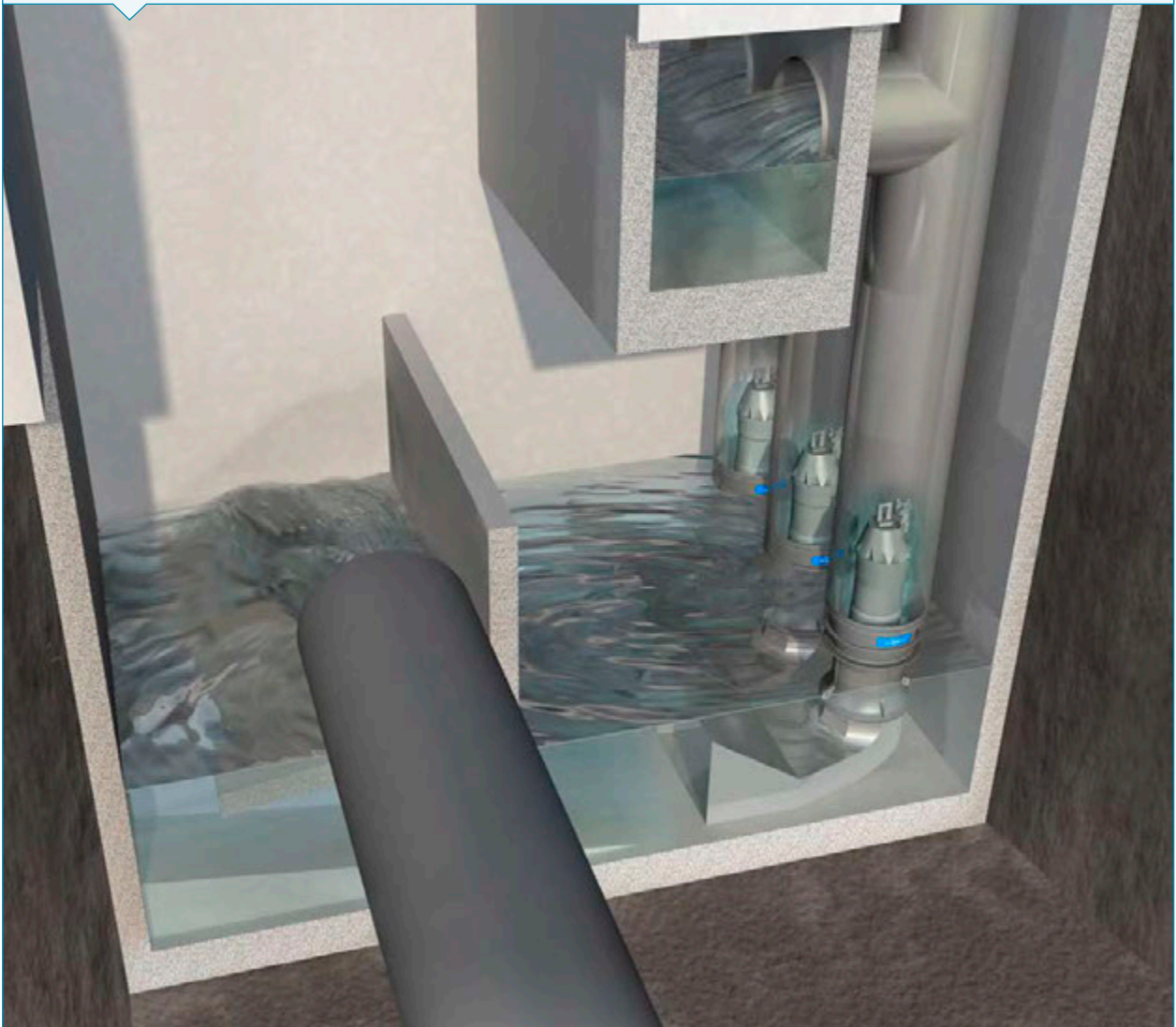

## CALCULATING THE ACTIVE SUMP VOLUME

The following formula can be used to calculate the active sump volume for any combination of flow rates between the pumps and the incoming flow.

$$V = \frac{3600 \times Q_i \times (Q_a - Q_i)}{S_{max} \times Q_a}$$

**V**= Active Volumes in Liters  
**Q<sub>i</sub>**= Inlet flow to sump in l/sec  
**Q<sub>a</sub>**= Average pumped flow (Q<sub>1</sub>+Q<sub>2</sub>)/2  
**Q<sub>1</sub>**= Total pumped flow at pump start  
**Q<sub>2</sub>**= Total pumped flow at pump(s) stop  
**S<sub>max</sub>**= Maximum allowable starts per hour

The formula can be simplified for the worst case scenario, where  $Q_i = Q/2$ .  
In that case the formula becomes.

$$V = \frac{T \times Q}{4}$$

**T** = 3600 / starts per hour  
**Q** = Total pumped flow in l/sec

The maximum cycle time depends on the number of allowable starts per hour. The number of allowable starts per hour is a function of the motor design and this information will be provided by the pump or motor manufacturer.

For a pump station with identical pumps, the required volume is smallest if the pumps start in sequence as the water level rises due to increasing inflow and stop in sequence as the water level drops due to decreasing inflow. For stations where more than one pump will often run at a time, there is a control strategy that can be used to maximize your available starts per hour and therefore minimize your active volume. This strategy involves having the last pump start also being the last pump to stop.

## B | NET POSITIVE SUCTION - NPSH

A positive head is required on the suction side of the pump to ensure safe operation and prevent cavitation. This is determined by the NPSH (net positive suction head) curve.

The basic condition to be fulfilled in all applications that contain rotating hydro machines, such as pumps, is:

NPSH <sub>a</sub> > NPSH <sub>r</sub>	
NPSH <sub>a</sub>	Available suction pressure due to atmospheric pressure, temperature and water level in the sump and inlet losses.
NPSH <sub>r</sub>	The pressure required to obtain a trouble free operation in terms of cavitation, the value is determined by the NPSH curve for the pump.
The NPSH <sub>a</sub> must be greater than the NPSH <sub>r</sub> at all times, and at all operating points, to ensure trouble free operation of the pump.	

The available suction head in a wet-installed pump application is:

$$NPSH_a = H_{ATM} + H_{SUMP} - H_{EV}$$

For a dry installed application, the dynamic head losses in the inlet pipe have to be taken into account. Consequently, the relation for the available suction head becomes:

NPSH <sub>a</sub> = H <sub>ATM</sub> + H <sub>SUMP</sub> - H <sub>LOSS</sub> - H <sub>EV</sub>	
H <sub>ATM</sub>	Atmospheric pressure
H <sub>SUMP</sub>	Difference in level between centerline of the impeller and lowest liquid surface in the sump
H <sub>EV</sub>	Evaporation pressure of the liquid
H <sub>LOSS</sub>	Dynamic head loss in inlet pipe system

## Installation tips for submerged pumps

### Follow these general installation guidelines for submersive pumps:

- | Avoid check valve cavitation by making sure the valve is not placed at an elevation greater than 8 meters above the pump discharge.
- | Include a trough in the floor of a station cable run to facilitate maintenance and protect the cables (refer to local electrical codes).
- | Separate low voltage sensor cables from higher voltage power cables where possible to prevent any noise from being added to the sensor signals. This becomes especially important in variable frequency drive applications.
- | Mount the cable support bracket/strain relief sheathing for easy access (i.e. within reach under the hatch).
- | Ensure that if a pipe or a hose is used to protect the cable, it does not cover the cable all the way into the control panel, as gases from the wastewater entering the cabinet could be harmful (refer to local codes).
- | Locate the control panel in a ventilated environment to avoid relay oxidation caused by wastewater gas.
- | Use a stilling well with an opening below the lowest water level. This will prevent problems with the operation of the level regulators due to floating debris.
- | In stations that have very high sediment levels, it can be beneficial to cover the pockets where the discharge connections are located. Use a steel plate or concrete to accomplish this and not allow an area for sediment to collect.



PLEASE SEE THE SEPARATE SECTION DETAILING EXCLUSIVELY WITH DRY INSTALLED PUMPS.

## C | THE FLYGT TOP STATION CONCEPT

Efficient transportation of solids that enter a sump is one of the main aspects of a pump station design. The build-up of sludge and solids of different densities is a problem that can occur in pump stations that have a poor design. To overcome this, Xylem developed in 1997 a self-cleaning patented sump design called the Flygt TOP station.

This hydraulic design prevents dead zones at the bottom by promoting fluid flow throughout the sump during pumping. The resulting increase in turbulence causes re-suspension of sludge, settled solids and entrainment of floating debris.

Additionally, the TOP geometry ensures that the only flat area in the sump for solids to collect is only directly below the pump suction area where the velocities and therefore shear forces are highest. Therefore the risk for sediment deposition while minimizing the volume of remaining water.

The reduction in buildup of sludge diminishes the risk of formation of noxious and corrosive which further increases the life time of the station and reduces costs. The original Flygt TOP concept, with the idea of a station with sloped areas with little flat areas inside them, forms the foundation for many of the station designs found within this guide.

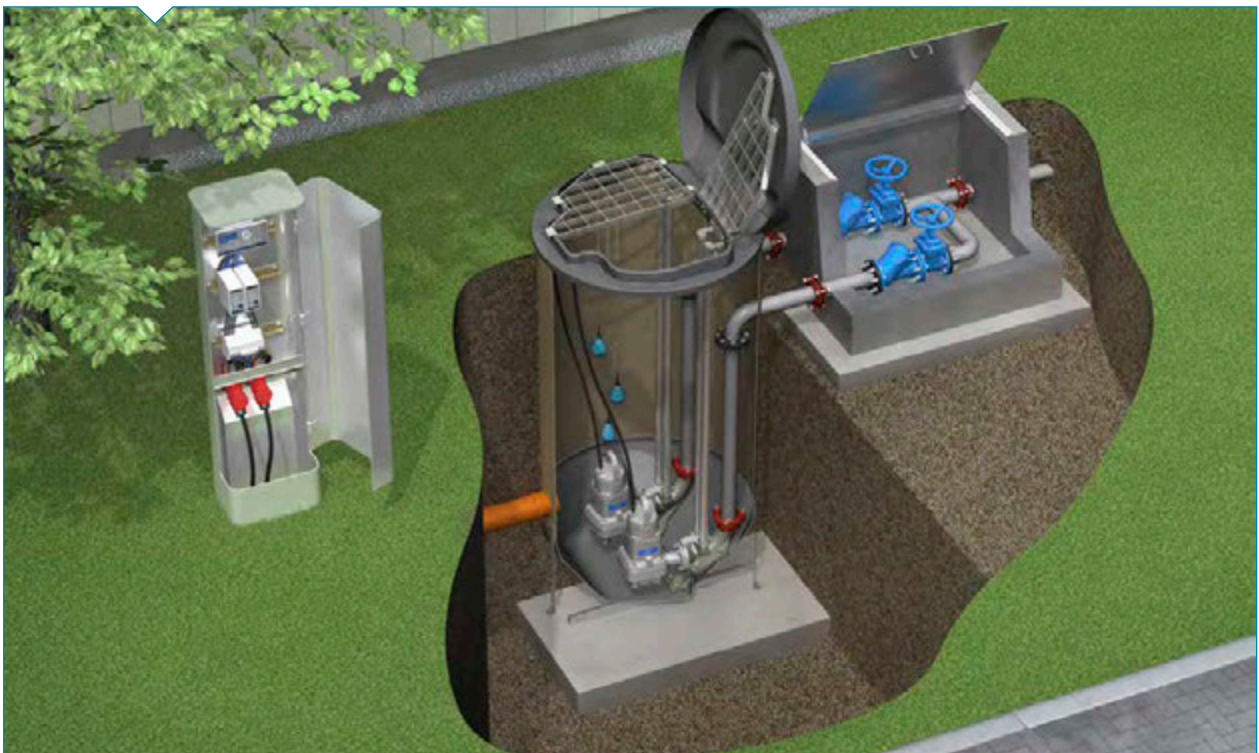

## D | IMPORTANCE OF THE DUTY POINT

In order to achieve the best possible pump operation, and maximize equipment life - it is very important to select the correct pump for the duty point in question. The preferred operating region (POR) for most large centrifugal pumps is between 70% and 120% of the Best Efficiency Point (BEP), as outlined in the Hydraulic Institute Standards. The Allowable Operating Region, (AOR) from BEP for optimal operation of centrifugal pumps in wastewater applications is between 50% 125% of BEP (unless the curve does not have an operational limit) and sufficient NPSH is available.

By running the pump outside the AOR the following problems can occur:

- | Unstable operation
- | Incipient cavitation resulting in impeller erosion, noise or vibration

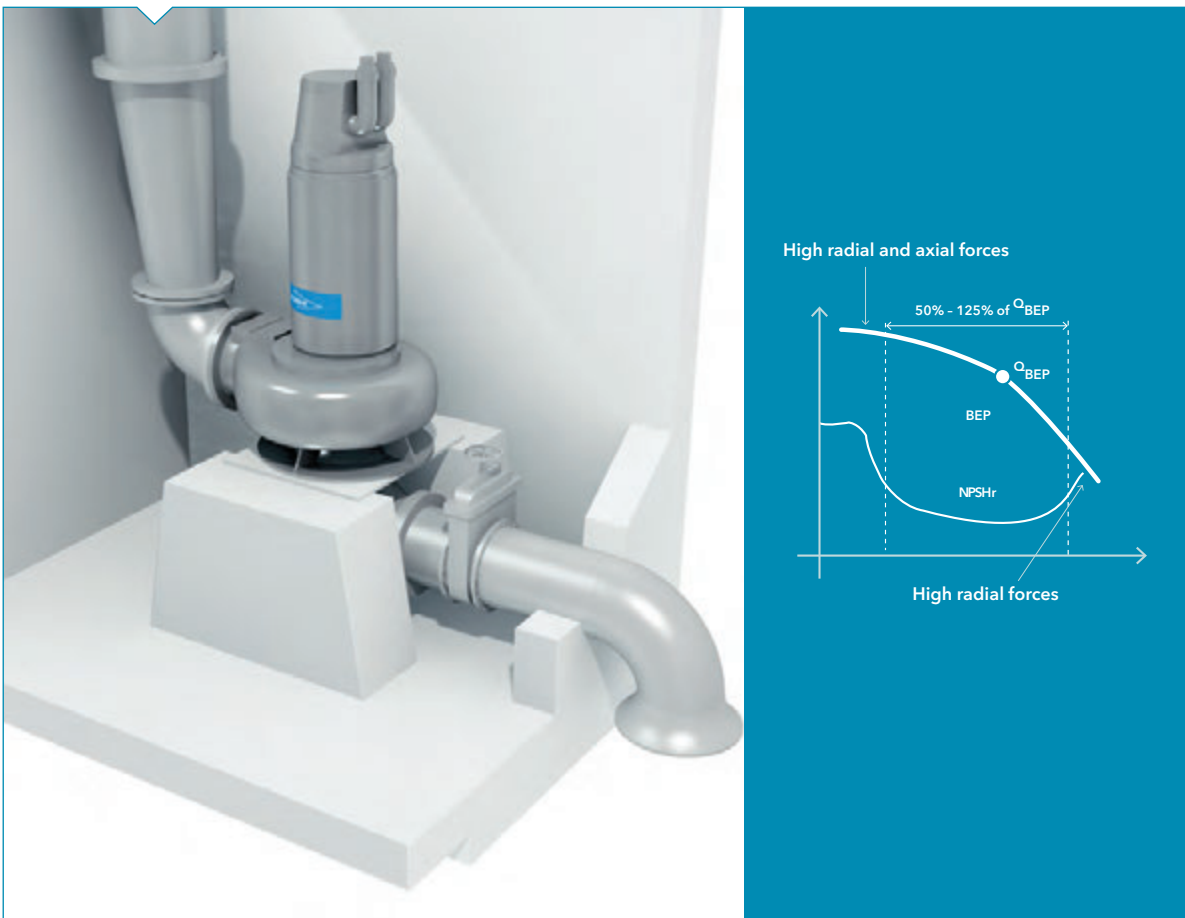

FOR ADDITIONAL INFORMATION ON THE EFFECTS OF THE DUTY POINT, SEE THE MORE DETAILED SECTION ON PAGE 87.

## E | HORIZONTAL AND VERTICAL DRY INSTALLATION OF FLYGT PUMPS

For customers or applications that require dry installations, Xylem offers the following possibilities for installation of submersible pumps:

- | Z for horizontally installed pumps
- | T for vertically installed pumps

Also, there is a complete section (link to page 44) discussing the specific case of dry installed Flygt pumps and topics important to that specific type of installation later in this manual.

In both cases, the use of Flygt submersible pumps makes the dry installation easier to maintain, safer and more cost-efficient, as well as keeping the benefit of delivering a flood proof solution. See the detail of the sump design for Z and T installations in the following sections of this manual and visit our website or contact your local Xylem representative to learn more about our installation kits.



## F | SYSTEMS ENGINEERING

We combine our know-how and experience with a broad range of suitable products for delivering customized solutions that ensure trouble-free operations for customers. Xylem utilizes powerful system engineering programs developed and verified based on decades of expertise and experience for design and development projects. Our scope of assistance includes a comprehensive analysis of the situation and proposed solutions - along with the selection of products and accessories.

## G | ADDITIONAL SERVICES

- | Optimization of pump sump design for our products and specific sites
- | Assistance with mixing and aeration specifications and design of appropriate systems
- | Support with system simulation utilizing computational fluid dynamics (CFD)
- | Guidance and organization of model testing
- | Direction for achieving the lowest costs in operations, service and installation
- | Instruction on specially developed engineering software to facilitate designing

Across our complete range of products and services, our philosophy is very simple:  
**There is no substitute for excellence.**



The following section covers details for sump designs using small to medium sized pumps.



## A | SMALL AND MIDRANGE PUMP SUMP DESIGNS

The station designs in this section are designed for pumps that operate between 10 and 450 liters per second (l/s). Pumps between this size are categorized as small and midrange pumps by Flygt.

For submersible installations, two alternative station types are described here. One station is a circular design that, as standard, can include up to two pumps. The other station is a rectangular design that can handle up to three pumps. Both of these stations types can also be generated into a CAD format using Xylem's SECAD design software.

### Midrange Sump Dimensions (Dimensional drawings follow on next page)

A (mm)	M (mm)	N (mm)	P (mm)	R (mm)	Max. Inflow Rectangular 3 Pumps (l/s)	Max. Inflow Circular 2 Pumps (l/s)	Discharge Connection Outlet (mm)	Flygt Product	Pressure Type	B (mm)
1200	210	420	145	290	110	57	65	NP 3069	SH	610
1500	260	520	180	360	137	88	80	NP 6020	HT	610
					151	88	100	NP 6020	MT	670
					137	88	80	NP 3069	MT	610
					137	88	80	NP 3085	SH	610
					137	88	80, 100	NP 3085	MT	610
					137	88	80	NP 3102	SH	610
					137	88	100	NP 3102	MT	610
					137	88	80	NP 3127	SH	610
1800	310	620	215	430	181	127	150	NP 6020	LT	670
					181	127	100, 150	NP 3102	LT	670
					165	127	100	NP 3127	HT	610
					181	127	100, 150	NP 3127	MT	670
2000	350	700	240	480	201	157	150, 200	NP 3127	LT	670
					183	157	80, 100	NP 3153	SH	610
					183	157	100	NP 3153	HT	610
					201	157	150	NP 3153	MT	670
					201	157	100	NP 3171	SH	670
					201	157	100	NP 3171	HT	670
2500	440	880	300	600	281	245	200	NP 3153	LT	720
					274	245	150	NP 3171	MT	730
					289	245	150	NP 3202	HT	770
					311	245	150	NP 3301	HT	830
					319	245	150	NP 3315	HT	850
3000	520	1040	360	720	410	353	250	NP 3153	LT	910
					477	353	250	NP 3171	LT	1060
					392	353	200	NP 3202	MT	870
					518	353	250	NP 3301	MT	1150
3500	620	1230	420	840	688	481	300	NP 3202	LT	1310
					683	481	250	NP 3315	MT	1300
4000	690	1380	480	960	900	628	300	NP 3301	LT	1500
					900	628	300	NP 3315	LT	1500

Circular

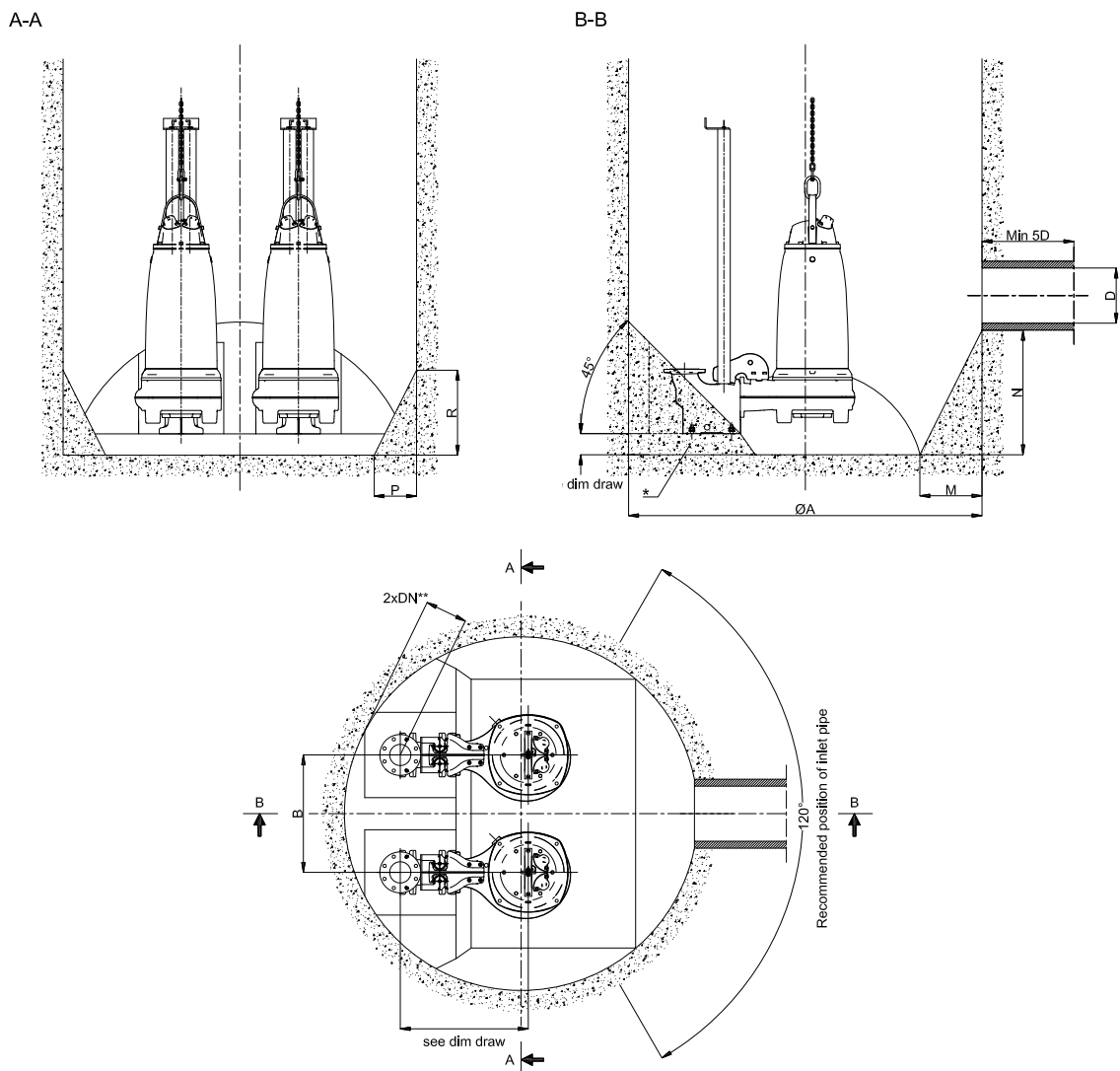

The drawings of these station types are generated using the SECAD design software which can be exported as pdf or CAD files. If the distance between the centerline of the pump station inlet and the sump bottom is  $>2 N$  the inner design of the sump may need to be modified.

- \* Dimensional Drawing of the pump
- \*\* If any pumps in the sump are to be equipped with a flush valve, this benching may need to be modified.
- \*\*\* Check that there is enough space for valves, bends etc. on the discharge pipe.

## Rectangular

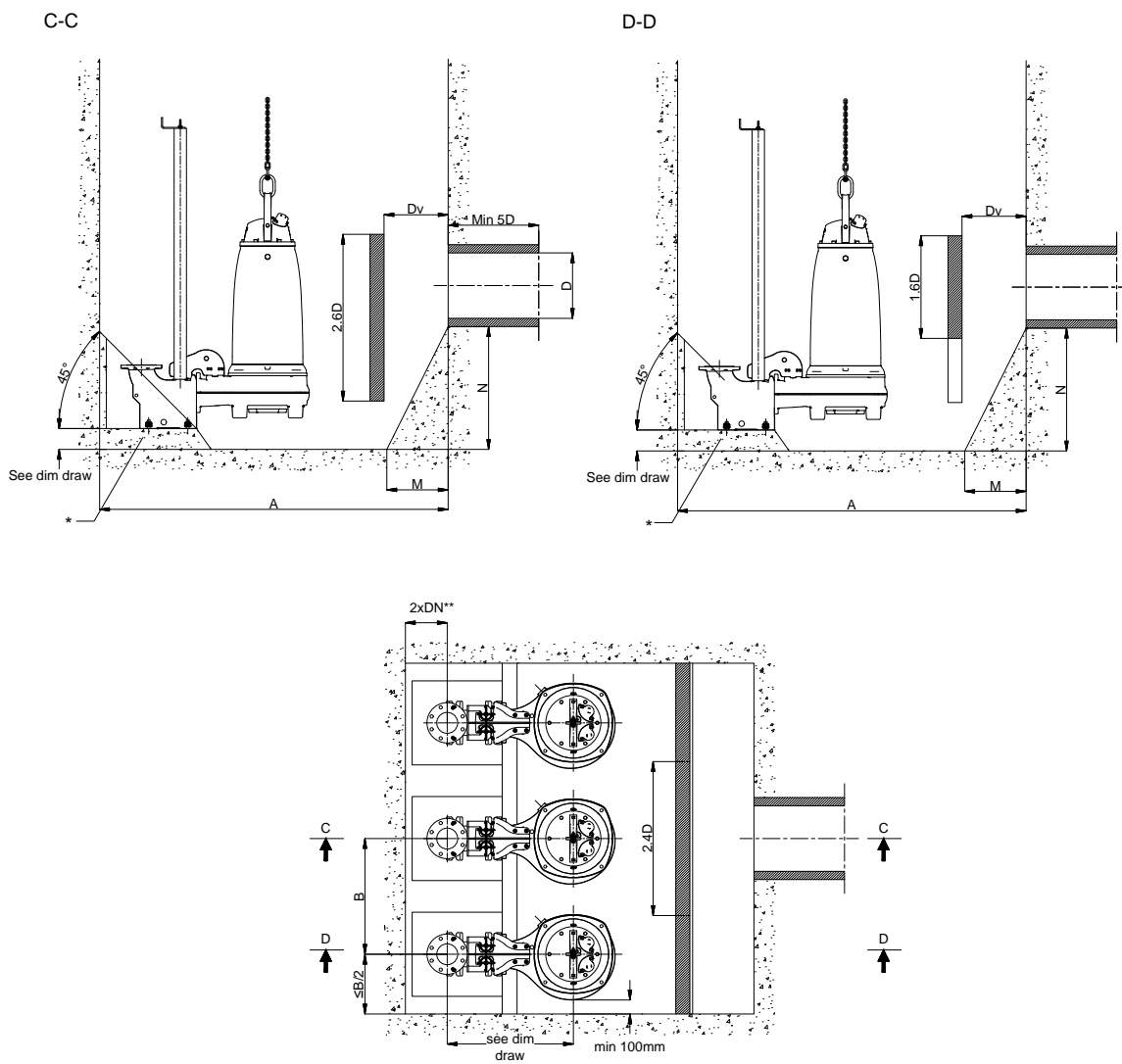

An inlet baffle should be used if three pumps are to be installed.

DN = Outlet of discharge connection.

\* If any pumps in the sump are to be equipped with a flush valve, this benching may need to be modified.

\*\* Check that there is enough space for valves, bends etc. on the discharge pipe.

## B | SMALL AND MIDRANGE DRY INSTALLED PUMP SUMP DESIGNS

The station designs in this section are designed for small and midrange size pumps that are dry installed. These pump station types have two separate areas: a wet well whose size is dependent on the flow of the pump, and a dry well where the size is determined more by providing physical access to the pumping equipment. In almost all situations the spacing between pumps will be determined by access restrictions rather than ensuring spacing for good hydraulics. It is important that both requirements are met when working with dry installed submersible pump station designs.

Station designs are available for between 1 and 4 pumps and for either a rectangular or circular station design. Using Xylem’s SECAD software, it is possible to quickly and easily generate a PDF or CAD drawing to be used in your pump station project. SECAD is able to quickly determine the correct size of the station based upon the access and hydraulic conditions for the pump and flow selected.

While it is possible to use these pump sump designs at all sizes that small and midrange pumps operate, it is recommended that for flows over 200 liters per second (l/s) some thought be given to transitioning to the large pump sump design. The large pump design is better suited to flows over 200 l/s and creates a smaller overall station do to the use of baffles, benching and splitters integrated into that station design.

### Dimensions for Small and Midrange Dry Installed Pump Station

Note: For flows above 200l/s it is recommended to compare this design to the large pump station design

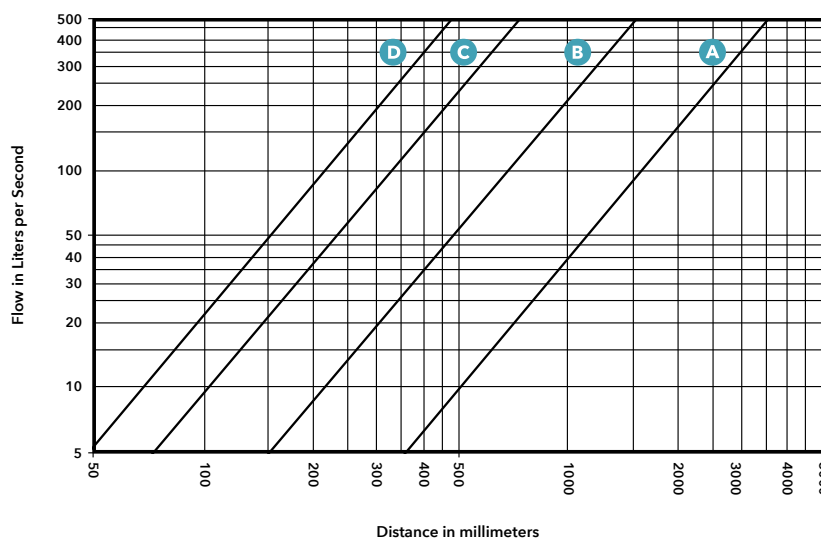

### Four Pumps - Rectangular Station T and Z

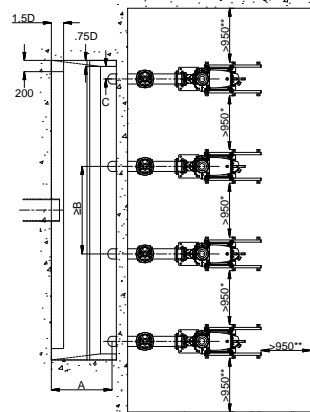
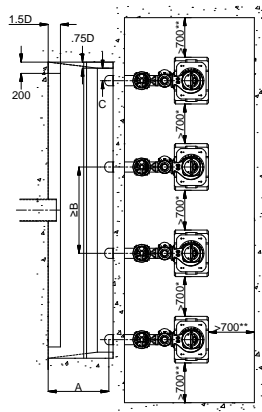
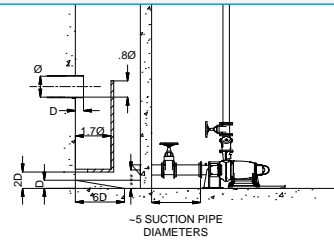
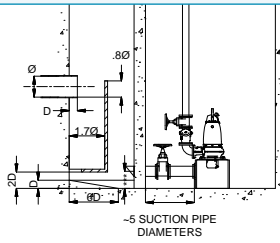

### Two Pumps - Rectangular Station T and Z

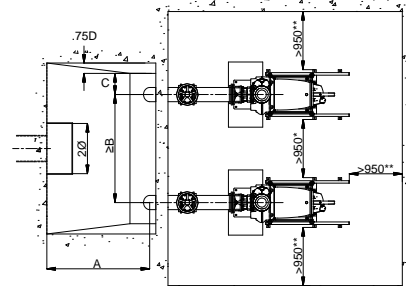
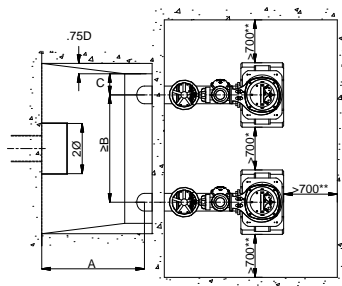
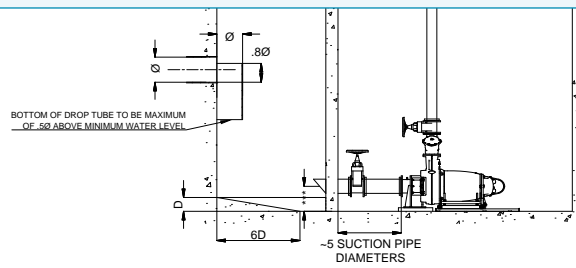
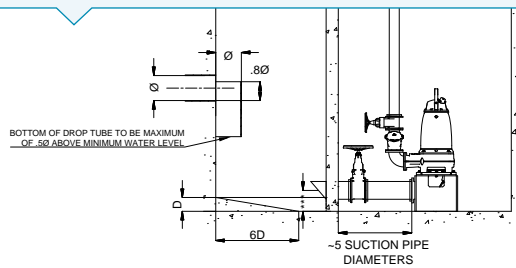

- \* Minimum recommended distance in millimeter between pumps and/or mounting equipment.
- \*\* Minimum recommended distance in millimeter between pump and/or mounting equipment and wall. Please note this distance may need to be increased to allow for removal of equipment.
- \*\*\* For dimension to the centerline of the pump suction pipe, please refer to the pump dimensional drawing.

Four Pumps - Circular Station T and Z

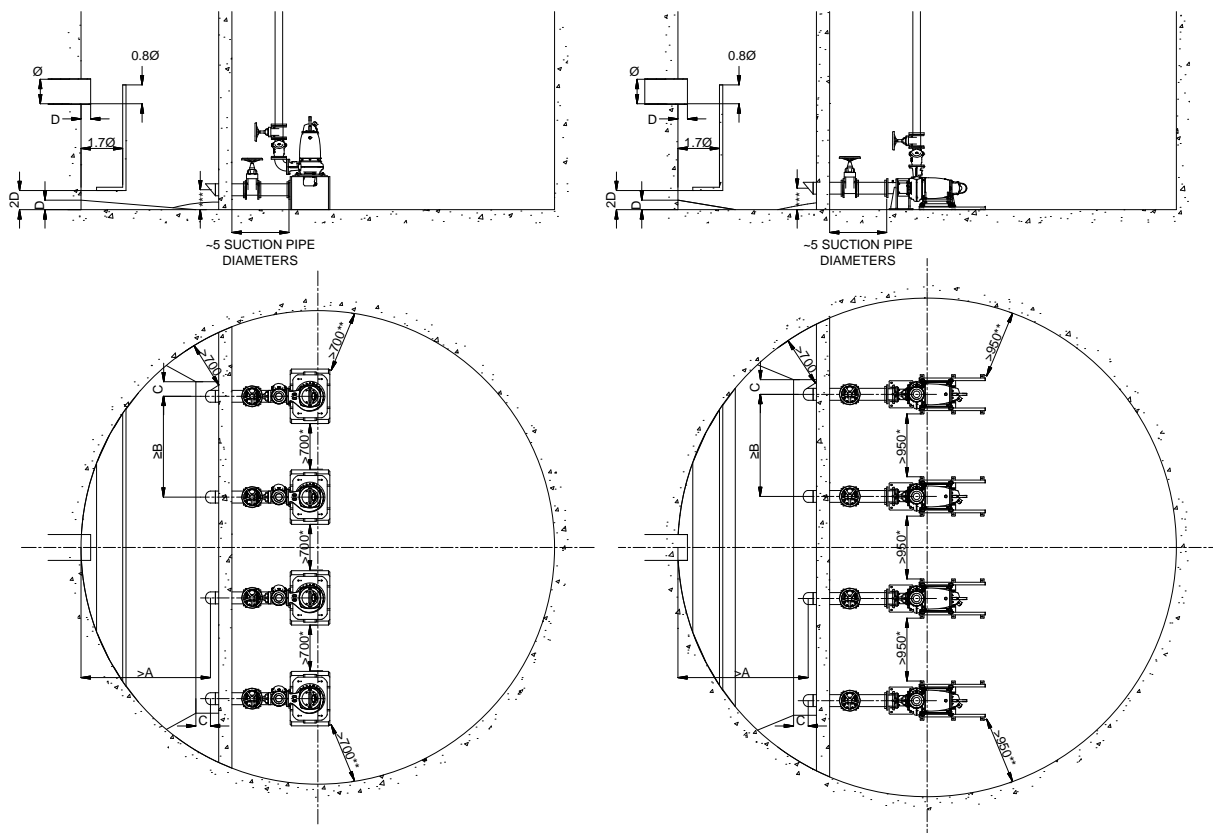

- \* Minimum recommended distance in millimeter between pumps and/or mounting equipment.
- \*\* Minimum recommended distance in millimeter between pump and/or mounting equipment and wall.  
Please note this distance may need to be increased to allow for removal of equipment.
- \*\*\* For dimension to the centerline of the pump suction pipe, please refer to the pump dimensional drawing.

## Two Pumps - Circular Station T and Z

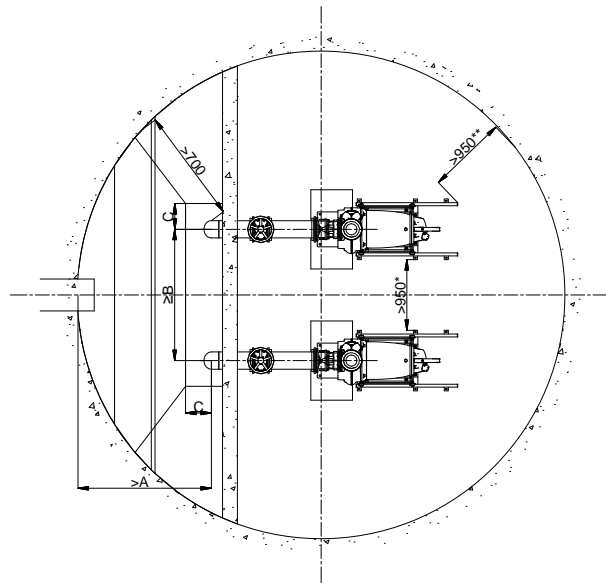
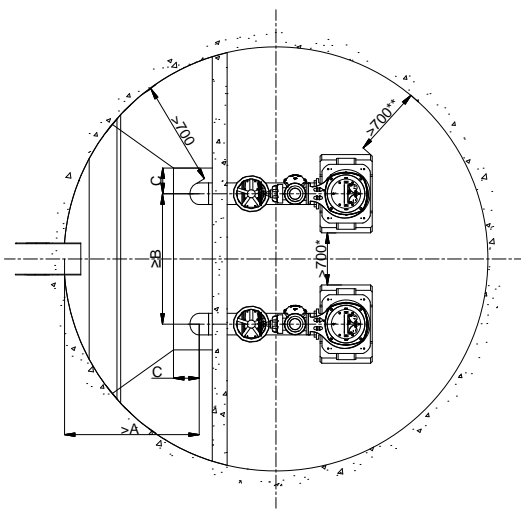
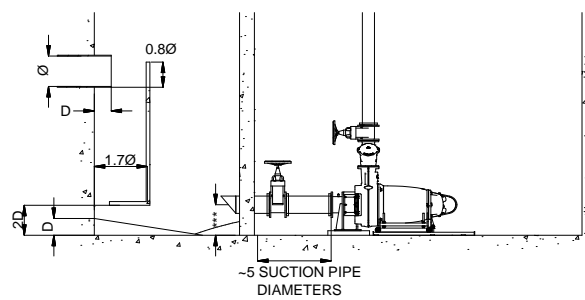
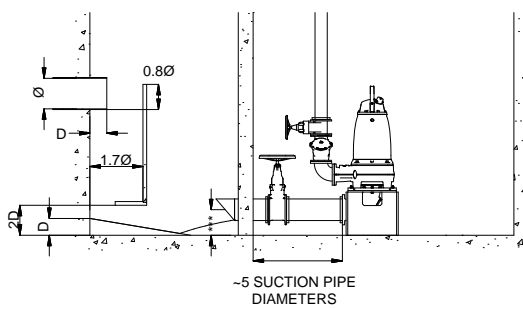

- \* Minimum recommended distance in millimeter between pumps and/or mounting equipment.
- \*\* Minimum recommended distance in millimeter between pump and/or mounting equipment and wall.  
Please note this distance may need to be increased to allow for removal of equipment.
- \*\*\* For dimension to the centerline of the pump suction pipe, please refer to the pump dimensional drawing.

**Xylem has developed pump station recommendations for stations with up to four pumps.**

## C | LARGE PUMP SUMP DESIGNS

For stations with large pumps (flows from 200 l/s to 3000 l/s), Xylem has developed pump station recommendations for stations with up to four pumps. These stations are compact and rectangular, they ensure good hydraulic performance of the station and provide for self-cleaning. The station guidelines shown below are all based upon the duty flow for the pump.

This flow should be the individual pump flow at the highest flow level the station will be designed for. Use this flow to determine what dimensions should be used for the values A through F and leverage Xylem's SECAD design software to quickly generate these drawings in a pdf or CAD format to use in your projects.

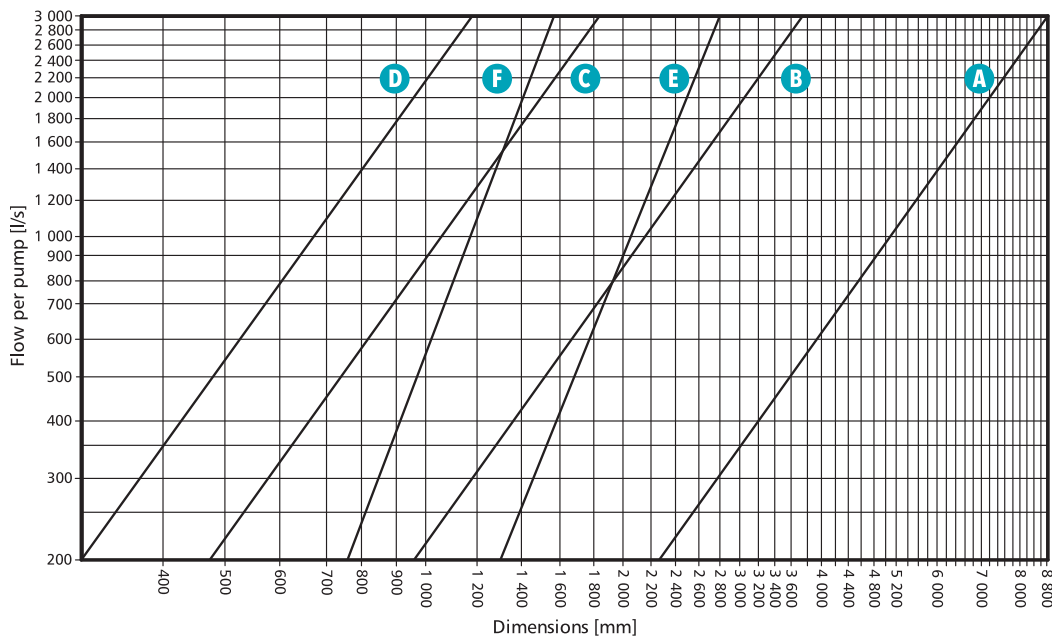

There are three standard layouts available for stations with large pumps:

- | A station with a high front inlet
- | A station with an inlet pipe situated to the side and elevated
- | A station with an inlet pipe situated to the side, but located at floor level

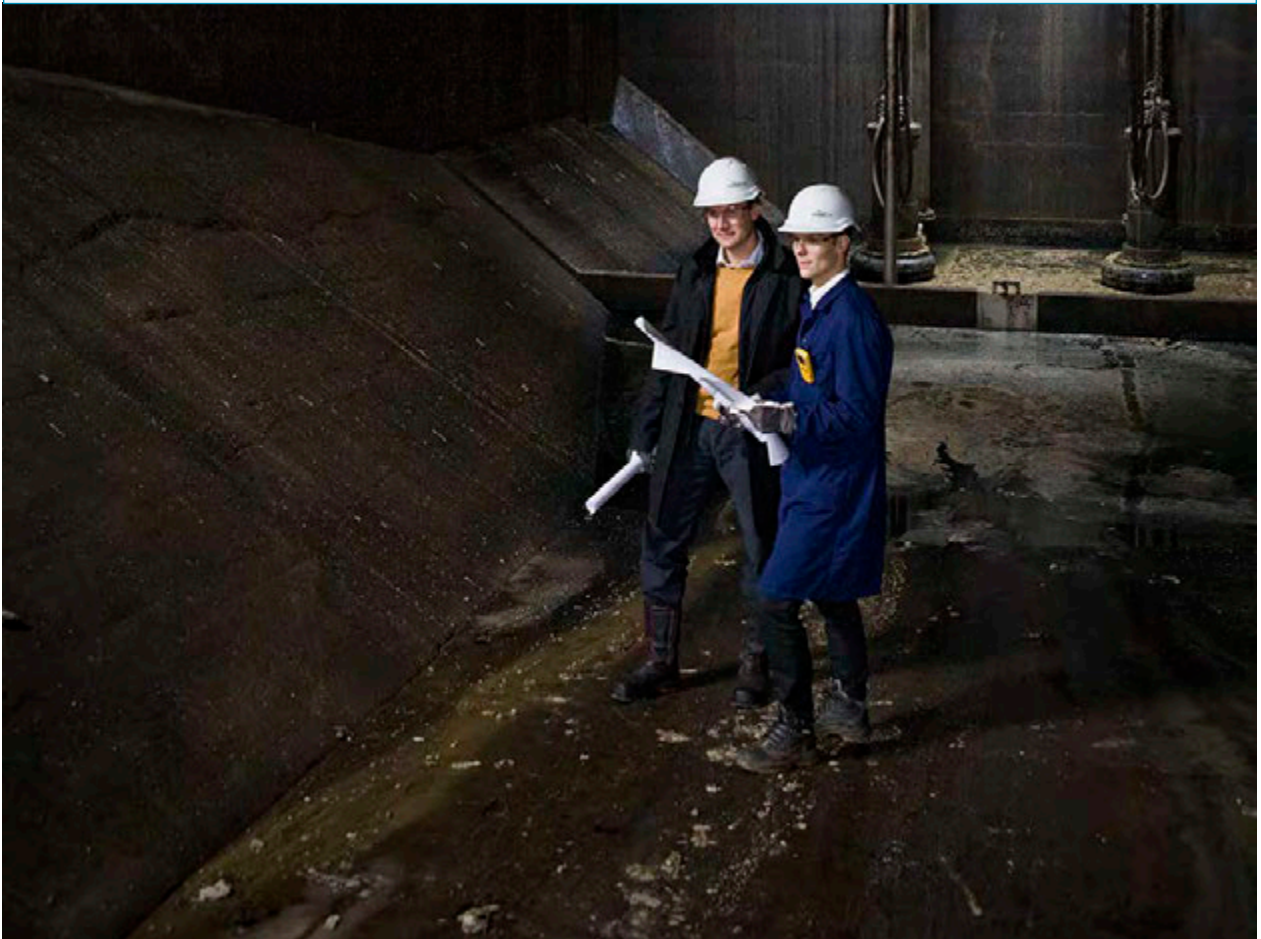

C1

A station with a high front inlet

SUBMERGED

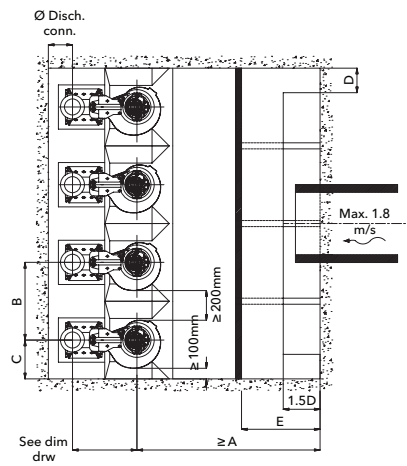
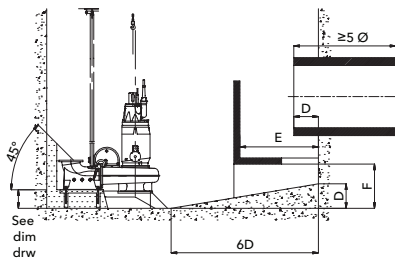

DRY - VERTICAL

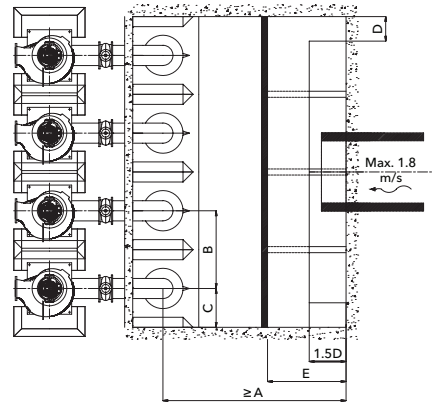
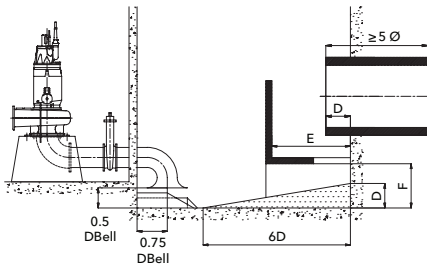

DRY - HORIZONTAL

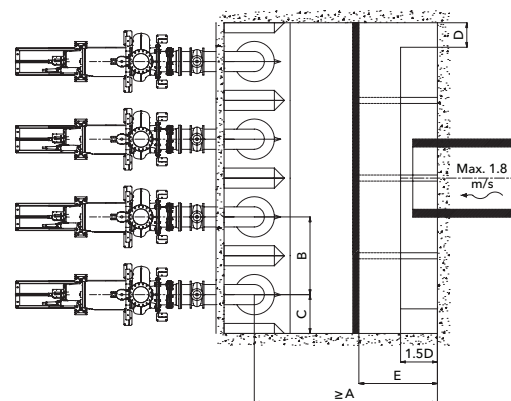
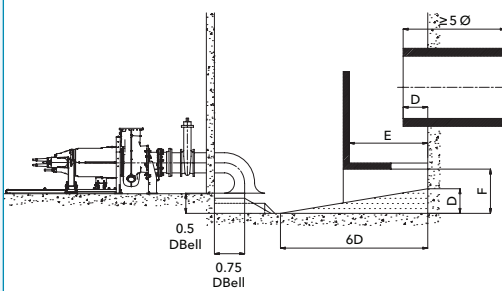

C2

A station with an inlet pipe situated to the side and elevated

SUBMERGED

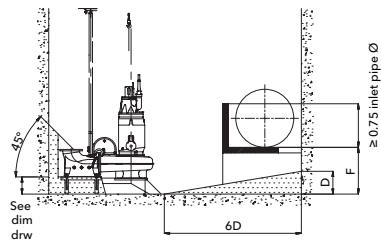

DRY - VERTICAL

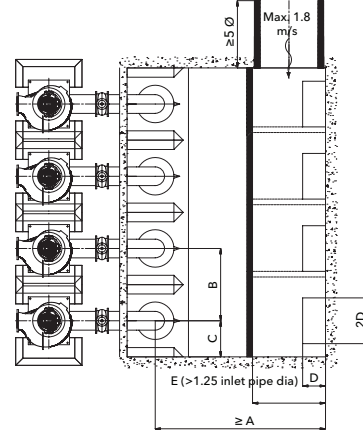
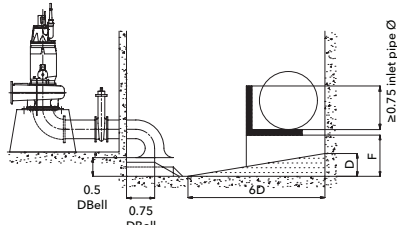

DRY - HORIZONTAL

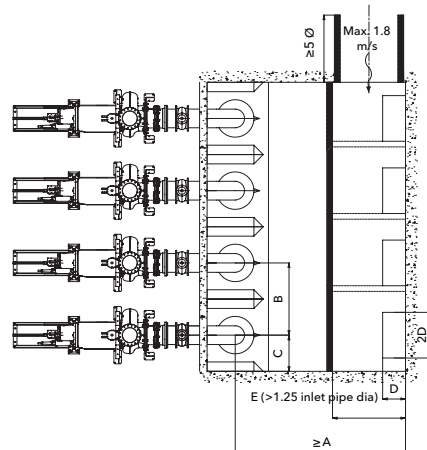
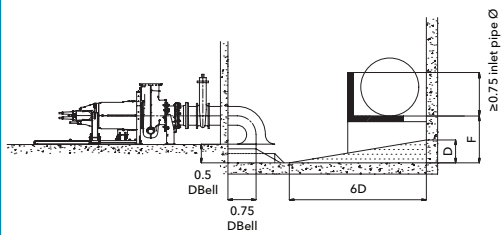

C3

A station with an inlet pipe situated to the side, but located at floor level

SUBMERGED

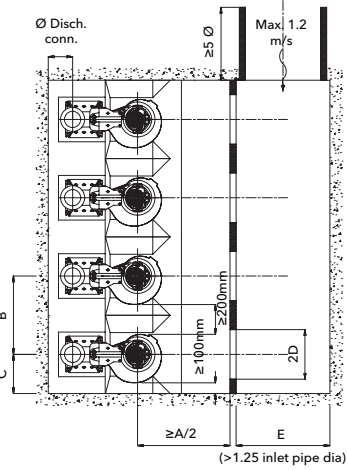
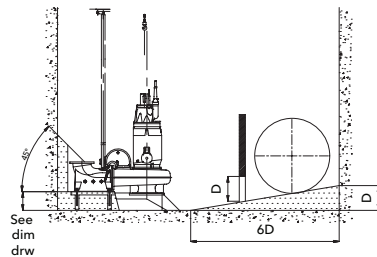

DRY - VERTICAL

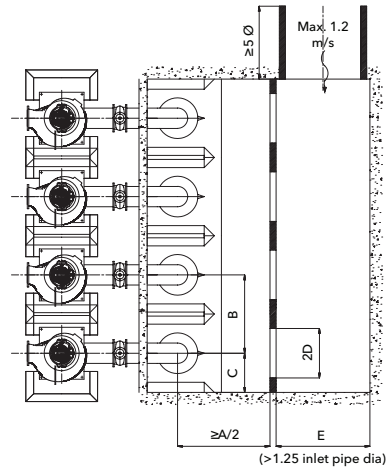
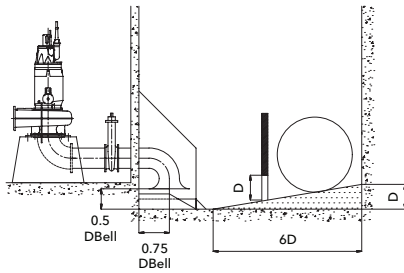

DRY - HORIZONTAL

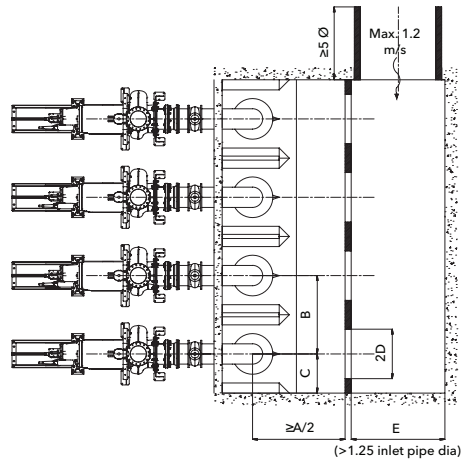
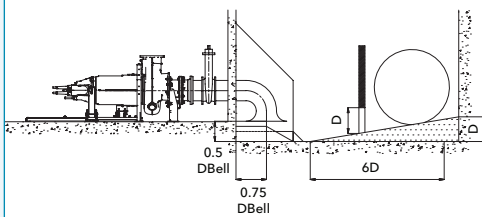



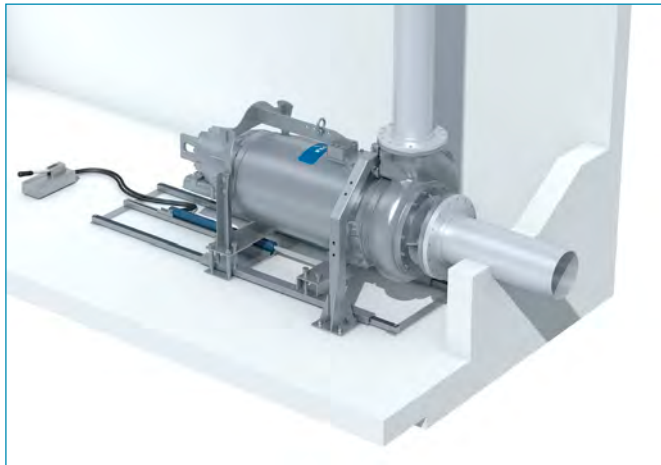

Flygt's entire standard design collection, including all of the station designs that are shown in this manual can also be found in Xylem's SECAD design software.

This software can quickly and easily generate a PDF or CAD file. SECAD is a handy reference tool no matter what stage a project is in.



CONTACT YOUR LOCAL XYLEM REPRESENTATIVE FOR DETAILED ADVICE.

Piping, fittings and supports that are mechanically connected to a pump are part of a single system.



It's critical to remember that all piping, fittings and supports that are mechanically connected to a pump are part of a single system. Because some parts are designed to turn at high speeds, some vibration is unavoidable. For example, the rotating mass of a motor, combined with forces from the motor and the hydraulic end, will generate an intrinsic set of disturbance - or "excitation" - frequencies that increase substantially when they coincide with a natural frequency of the system. This is more common in variable speed applications containing pumps that can operate over a range of speeds, rather than a single constant speed.

Properly installing and anchoring Flygt pumps and accessories will help limit vibration and enable reliable, trouble-free operation. In vertical installations, the tall unsupported mass of the vertical motor exacerbates vibration levels at the upper bearing caused by imbalance, poor installation quality or hydraulic disturbances. More so than in horizontal installations, eliminating system resonances and ensuring high quality installation in vertical pumps is critical to achieving an installation with smooth-running operation.

**This section of the design recommendations includes the following topics:**

- | Recommendations for reliable dry pit installations with minimal noise.
- | Requirements for the anchoring of the pump and the connecting pipes.
- | Factors affecting sound and noise levels.
- | Recommendations when special considerations should be taken.
- | And other topics that are important to dry pit installations.

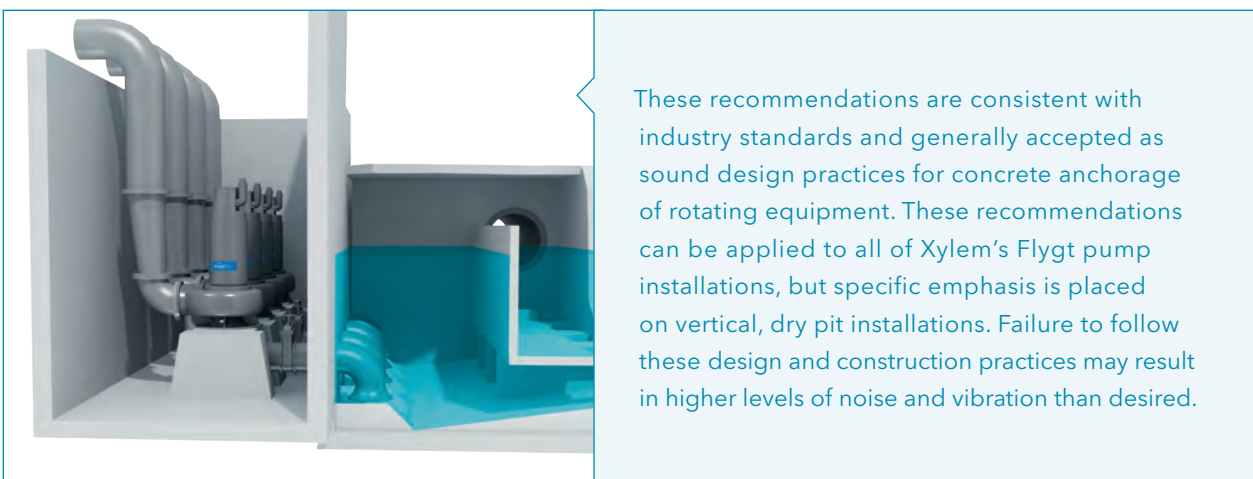

**Consult a licensed Civil Engineer for specific construction design details for each individual installation. Please consult your local Xylem representative to achieve optimum performance and maximum life of the installation.** We would provide anchor bolt load calculation using the Flygt Engineering Tool (FET) software if further anchor bolt analysis is needed. The design recommendations are only valid for Xylem equipment. We assume no liability for non- Xylem equipment.

### A | VIBRATION

- | All structures have frequencies that are easily excited, whether natural or resonant. When a structure is hit with a short pulse that contains all frequencies, it will vibrate with its natural frequencies.
- | Vibration levels will increase substantially when the frequencies of the motor coincide with the natural frequency of the system.
- | The likelihood of this occurring increases for variable speed applications where the pumps can operate over a range of speeds, rather than a single constant speed. Most Variable Frequency Drives have the option to exclude certain frequency ranges to avoid regions of high vibrations.

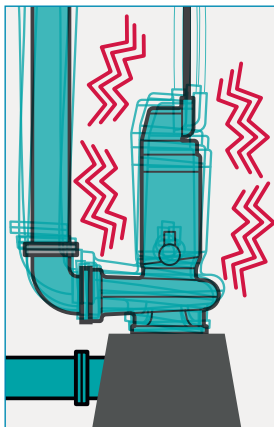

Flygt pumps are manufactured to ensure compliance with pump test standards. ISO and HI set vibration limits that are between 6.4 and 9 mm/s depending on shaft power and test standard followed. Although the pump itself can withstand higher vibration levels (3 or 4 times the testing limit) without noticeable life time reduction, the piping and supportive structure may suffer and crack if vibration levels are too high. Please note that pumps at standstill are more sensitive to vibrations than when they are operating, because bearings can be damaged while at rest if the vibration is high.

- | Attain acceptable vibration levels in the field by ensuring all parts of the system are sufficiently rigid and firmly anchored. Proper anchoring helps keep primary disturbance frequencies below the lowest natural frequency of the system. Instructions on how to properly anchor your system will follow.
- | High vibration risk amplifies as the amount of clogging matter in the pumped liquid increases. The clogging of the pump not only reduces the performance, but also brings an unbalance into the impeller. This makes proper anchoring even more important when pumping sludge and raw sewage.

## B | NOISE

Sound results from pressure changes in a gas, fluid or a solid structure. Undesirable sound is usually referred to as noise. While noise can never be totally avoided, well-designed stations may help keep it at acceptable levels. Control noise levels by first identifying its sources and understanding the mechanism of noise generation.

Pressure changes can be transmitted to the air from a vibrating structure, which results in noise. The stronger the transmission from the vibrating surfaces to the air, the higher the sound levels will be. Structure-borne vibrations can travel some distances before becoming airborne and audible. Liquid-borne pressure fluctuations can travel very far before causing the structure to vibrate and generate noise. Consequently, the source of the vibrations causing the noise is not necessarily in the same location as the noise itself.

Liquid-borne pressure fluctuations in the pipe can also occur at high head conditions with impellers that have a low number of vanes (pulsations due to blade pass).

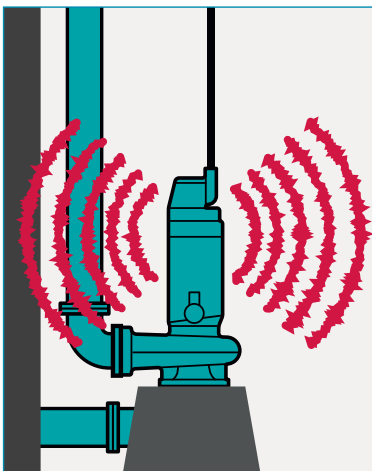

This can be a major cause of complaints in residential areas. It is important to remember that disturbances generated from the electrical motor, cavitation and other flow-induced vibrations significantly affect the sound level. The noise level increases with deviations from best efficiency point and are particularly prevalent towards the maximum flow. Pumps are not the only source of noise generation in a pump station. Valves and piping also add to the total sound level. The following table shows how each part of a pump station contributes to the overall sound level and explains how pump type affects noise generation.

Station Components	High or Super High Pressure Pumps	Low or Medium Pressure Pumps
Pumps	60%	30%
Pipes and Valves	20%	30%
Force Main	20%	40%

To simulate the human sound experience, sound level meters have a frequency filter, noted as A-weighted, that reflects the human hearing pattern. Sound pressure ( $L_p$ ) is measured in dB(A) which gives more weight to frequencies where the human ear is more sensitive. dB(A) is the most appropriate scale of measurement when evaluating noise within a pump room. The noise from the pump is normally given as the sound power level ( $L_w$ ).

Sound power level can be amplified depending on the acoustics in the pump station. The position of the pump and the wall material in the station will affect how much sound power is present in a station. For example, a pump should never be installed in a corner. A noise test according to the ISO standard (9614-2) can be performed on the pump.

### C | INLET CONDITIONS

Use the following guidelines to minimize the noise and vibration that can be caused by the inlet conditions of the pump. Extra equipment must be added when a submersible pump is installed dry mounted.

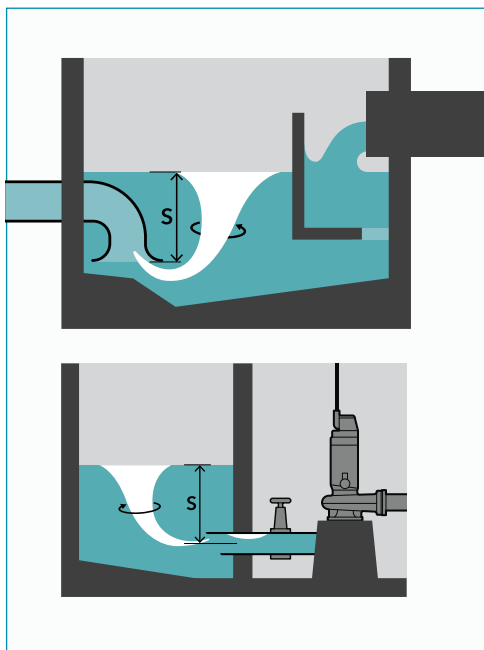

The normal procedure is to install a shut-off valve on the inlet pipe, which is also equipped with one or two elbows.

To provide as uniform and loss-free flow to the inlet of the pump as possible, the inlet design should fulfill the following criteria:

- | Provide sufficient NPSH<sub>av</sub>
- | Minimize friction losses
- | Minimize number of elbows in the suction pipe system
- | Eliminate vapor from suction line
- | Ensure correct pipe alignment

Severe space restriction is the only acceptable reason for not providing a suitable inlet condition. If this is the case, examine the hydraulics prior to pump operation.

### Swirl Angle in Degrees

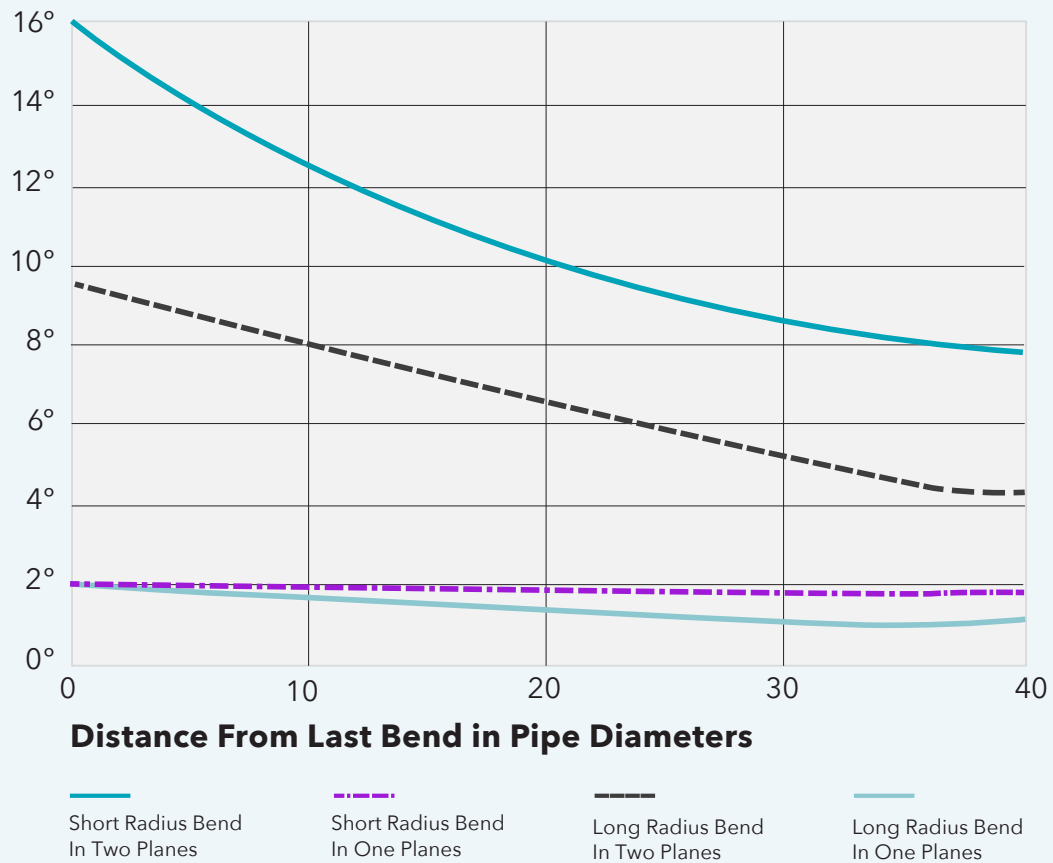

If elbows are used, proper orientation is crucial. If all elbows are located in one plane, the effect on the flowing hydraulics is small compared to elbows located in two or more planes. Measurements show that the swirling effect is dependent on orientation, bend radius, distance between the bends and distance from bend system. The diagram shows swirl as a function of the distance from the last bend, with two different radii and number of planes involved, with a distance of two times the pipe diameter between the bends.

Although an inlet pipe to a dry installed pump acts as a flow straightener, it can in itself cause unsteady flow. In most situations, pipe bends are used due to the upright position of the pump which can amplify the unsteadiness of flow. A suction bell inserted parallel to the sump floor on the other hand, creates flow acceleration and reduces the unsteadiness of flow.

Select pipe bends and suction bells with care to minimize the disturbance to the flow. Smooth bends are always preferred to sharp mitered bends. Long radius elbows and/or reducing elbows are recommended, especially for the elbow connected to the pump. As a general rule, include 5 to 10 pipe diameters of straight pipe between bends, and between the bend and the pump, to reduce the disturbances. A pump installed in a horizontal configuration will ease these problems as fewer below will be required for most of the applications.

In sludge applications, a horizontal pump installation with the outlet positioned straight up is recommended. This outlet position helps avoid gas blockage in the pump. Keep the inlet pipe as short and simple as possible to enable the liquid to spontaneously enter the pump. Avoid using elbows in the suction pipe. Include sluice-type valves and place them as close as possible to the pump in order to avoid a large spill if the system needs to be disassembled.

Provide the inlet with a bell mouth to accelerate the flow smoothly into the inlet pipe and reduce inlet losses. Smaller pumps (pipe diameters less than or equal to 400mm) do not require a bell mouth, as the inlet size produces an acceptable velocity. In stations with high solids content, the bell mouth ensures removal of solids from the floor. A 45-degree cut is provided in this configuration for swirl prevention as illustrated in figure on [page 48](#).

<b>The submergence for the inlet pipe should be:</b>	
For symmetrical approaching flow: <b><math>S = 1.7 \times Fr \times D</math></b>	<b>S = Submergence (m)</b> <b>Fr = Froudes number</b> <b>D = Pipe inlet diameter (m)</b>
For lateral approaching flow: <b><math>S = 2.3 \times Fr \times D</math></b>	

See drawing on [page 48](#) where submergence should be measured from in different conditions.

For larger pumps, a bell mouth with an opening of 2 times the inlet pipe diameter should be used (2×D). This value replaces the value for the inlet pipe diameter (D) in the above equations for an inlet with a bell mouth, a minimum submergence depth of one bell diameter should be considered. This depth almost always prevails the equation above if operated with recommended velocity values.

$Q \leq 300$ l/s	$0.6 < v < 2.8$ m/s	<b>Recommended velocities for inlet pipes based upon pump flow.</b>
$300 < Q \leq 1200$ l/s	$0.9 < v < 2.4$ m/s	
$Q > 1200$ l/s	$1.2 < v < 2.1$ m/s	

Froude number is defined as:

$$Fr = \frac{v}{\sqrt{g \times D}}$$

*v* - inlet water velocity (m/s)  
*D* - inlet diameter (m)  
*g* - acceleration due to gravity (m/s<sup>2</sup>)

**Submergence [m]**

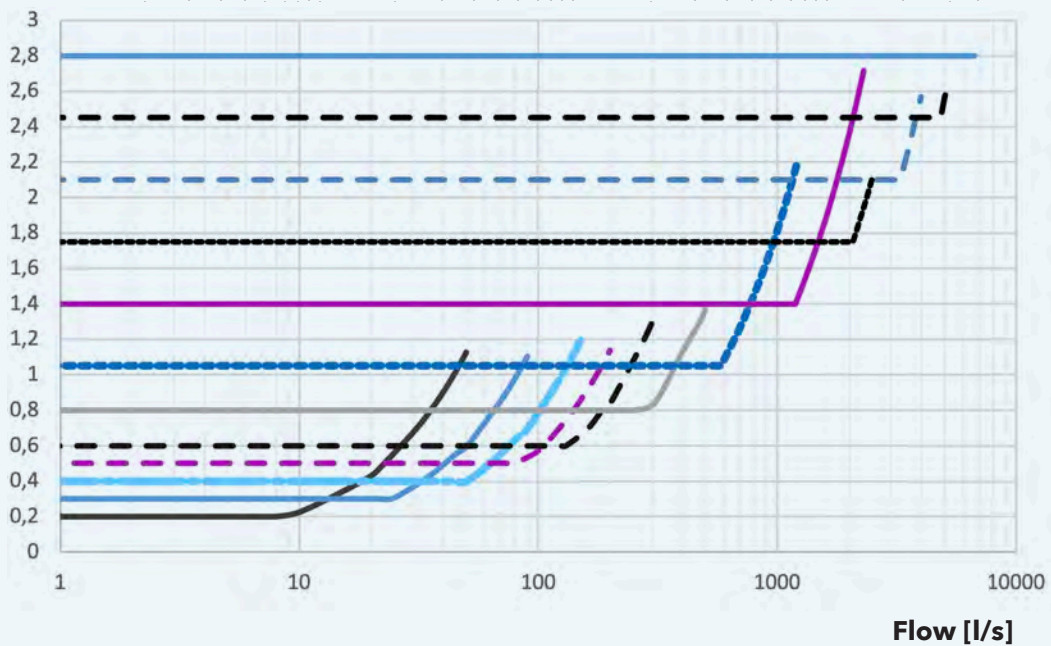

**Pipe Diameter**

- |               |             |             |                |
|---------------|-------------|-------------|----------------|
| — 100mm       | - - - 250mm | ..... 525mm | - . - . 1050mm |
| - . - . 150mm | - - - 300mm | - - - 700mm | - - - 1225mm   |
| - . - . 200mm | - - - 400mm | - - - 875mm | - - - 1400mm   |

Submergence depth is considered from the water surface to the center of the inlet pipe or the bell-mouth entry as illustrated on page 48. A fully symmetrical approach is considered to calculate the submergence depth ( $S=1.7 \times Fr \times D$  when  $S \geq 2 \times D$ ).

### D | PIPING SUPPORT

Xylem pumps will generate disturbances that are transmitted to the adjoining pipe and structure through mechanical connection of the piping and the installation structure. Pump speed (imbalance) and blade pass (hydraulic forces) typically are two frequencies at which disturbances can occur. These frequencies can be used to estimate the critical pipe length; i.e. the natural bending frequency of a pipe filled with liquid.

- | Xylem recommends that the distance between pipe supports be set at 70% of the critical length (for assistance with the calculation on pipe length, please contact your Xylem local representative) for the first mode.
- | Ensure pipes have a support located at a distance of 1/3 of the critical pipe length from the pump.
- | Properly support heavy parts of the piping system, such as valves. Gate valve, non-return valve (NRV) and pipe up to NRV should all be supported to allow for the removal of the NRV without loading the adjacent pipe work.
- | Because vibrations are independent of gravity, horizontal supports should be included since they are as essential as vertical supports. Account for thermal elongation.
- | The anchorage must be able to safely absorb and withstand the pump shut off pressure thrust load. This is especially important for long pipes and any possible water hammer loads.
- | Support piping with the surrounding structure, not by couplings or pump flanges.

### E | SOFT INSTALLATION ALTERNATIVE

In some cases, it may be necessary to explore alternative methods of installation. For example, natural frequencies may exist that make it difficult or impossible to adequately reduce vibration levels. Variable speed applications are far more likely to experience these problems due to the wide range of pump frequencies.

If flexible joints are used, the piping must be well anchored. The presence of flexible joints between the pump and pipe can transform pressure fluctuations into disturbances, causing severe vibrations in the piping. Be aware that new modes of motion may occur that have to be handled. Soft installation is difficult to design and proper analysis is vital in order to achieve the desired result. As a result, Xylem recommends this type of installation only be designed by an experienced civil engineer.

If system resonance cannot be resolved by adding stiffness or mass to the system, or if resonance is predicted through system analysis, then it may be necessary to modify the pump installation in the following manner:

- 1 | Provide vibration isolation (bellows or flexible joints) at the pump suction and discharge flanges.
- 2 | Provide adequate support of piping immediately adjacent to these joints.
- 3 | Provide a concrete base of at least 2x the mass of the pump and motor.
- 4 | Anchor the Flygt pump firmly to the base.
- 5 | Provide machine feet or rubber carpet between the base and the floor of adequate dimensions.
- 6 | Please note that the force from the fluid pressure has to be supported.

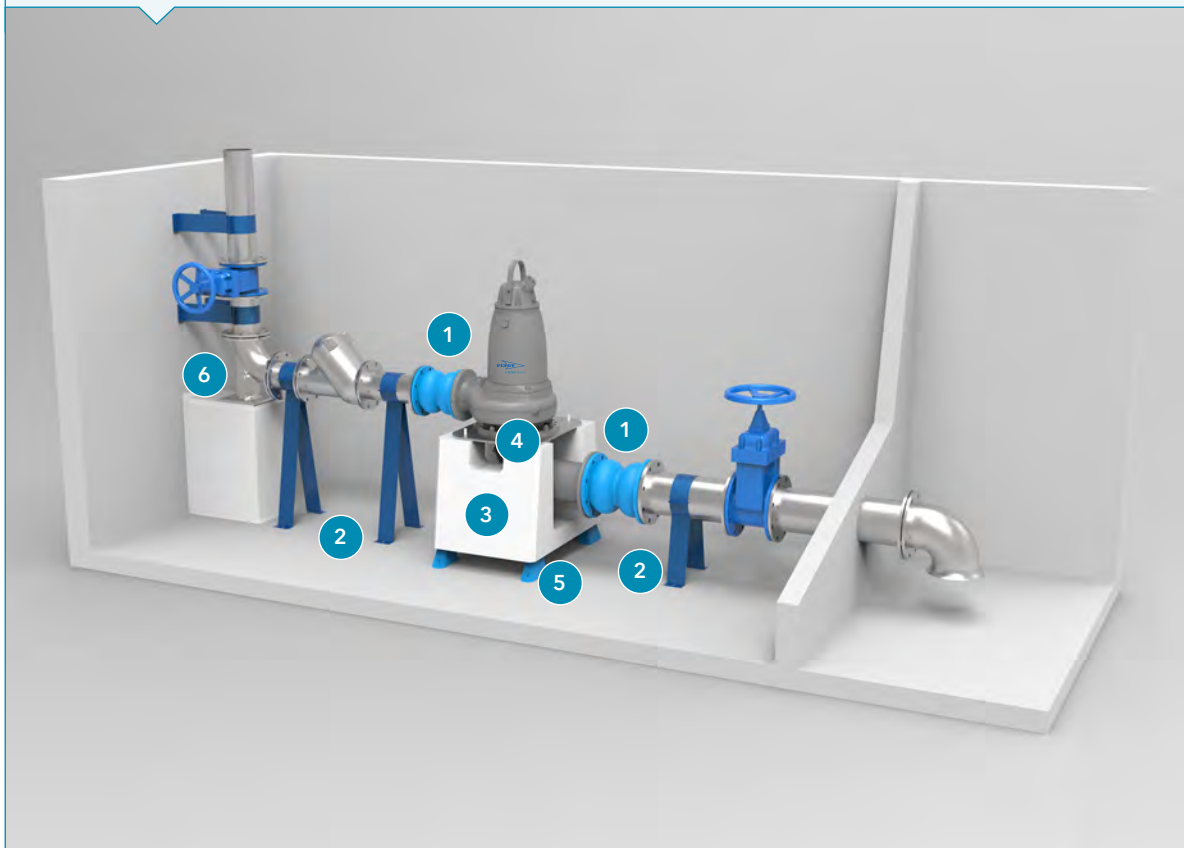

### F | THE GOOD DRY PUMP STATION

Aside from pumps, there is a list of items that should be considered in every dry pit pump station.

These items include:

- | Ease of maintenance for the pumps (clearance).
- | Ease of removal of pumps in case of repair (this includes appropriate lifting equipment).
- | A station flow meter with the correct installation requirements.
- | Suction and discharge gauge taps for station testing and troubleshooting.
- | Correct valve selection and placement.
- | Adequate velocity in piping to ensure transport of solids. This should be at least 0.7 m/s. Testing has shown that vertical pipe sections do not need an increase in velocity to ensure transportation of solids.
- | Bypass possibilities for emergency situations or upgrade work.
- | Ease of emergency power connection in case of a long duration power outage. This includes either an onsite generator or the inclusion of a generator socket for use with a portable generator.
- | Electrical equipment that is either protected from water intrusion or placed at levels above in case of flooding of the station. This will ensure pump availability in emergency situations.

**Make sure the station design is large enough to ensure proper operation and easy maintenance during both emergency events and general visits.**

This will help keep the station clean and clear of problems. Additionally, the dry well may need to be much wider than the wet well to provide suitable clearances for access to pumps, piping and valves.

## G | EFFECTS OF OPERATION ON PUMP NOISE AND VIBRATION

Improper pump selection can lead to high vibration and noise. There is a limited area around a pump's best efficiency point where noise and vibration are very low, and moving outside this range results in higher vibration and noise levels; either through flow recirculation or increased velocities in the pump. There are also various non-pump related situations that contribute to increased noise and vibration.

The use of slow closing valves is one such situation. Slow closing valves are normally used to reduce pressure spikes that result when a pump starts or stops. But they also create a situation in which the pump runs at shutoff head for a period of time, which results in higher vibration and noise during these times. Poor valve placement can also increase noise levels. If a valve is placed close to an elbow, uneven flow will cause increased sound to be emitted from the valve.

### **Variable frequency drives (VFD) can cause an increase in sound and vibration in multiple ways:**

- | If the resonant frequency of the system is within the pump operating range, the variable frequency drive can cause the pump to operate at the resonant frequency - causing a drastic increase in vibration and sound.
- | The carrier frequency of the variable frequency drive can cause the pump motor to "ring out" in the audible hearing range. Xylem recommends having the carrier frequency of the variable frequency drive set in the 2-3kHz range.
- | Variable frequency drives can reduce the speed of the pump such that the pump starts to operate close to shut off. This will cause an increase in vibration and noise due to recirculating flow in the pump volute.

When operating multiple pumps in a common force main, vibration and noise will increase as more individual pumps start to operate further from their best efficiency points.

**This scenario is especially likely if the single pump's duty is defined to the left of the BEP.**

Take care to ensure that all operating possibilities are looked at in the design phase to create good hydraulic conditions. For example, the rotating mass of a motor, combined with forces from the motor and the hydraulic end, will generate an intrinsic set of disturbance - or "excitation" - frequencies that increase substantially when they coincide with a natural frequency of the system. This is more common in variable speed applications containing pumps that can operate over a range of speeds, rather than a single constant speed.

In sludge applications, pumps can encounter variations in thickness of pumped media. If a high percentage of sludge suddenly comes through the pump, vibration, noise and motor temperature will all increase until the concentration passes.

## G1

### UPGRADING DRY PIT PUMP STATIONS - NOISE AND VIBRATION CONCERNS

Upgrading a dry pit pump station presents a unique challenge when it comes to noise and vibration. Examine the following areas before upgrading a dry pit pump station:

- | Changing pipes during a pump station upgrade can greatly affect the critical length of the system. During this process, materials with a different density and vibration characteristic could suddenly push the system into operating at the resonant frequency where previously there were no problems. Additionally, certain pipe materials, such as cast iron, are very poor at transferring sound. Removing these pipes and replacing them with steel or stainless piping can result in increased noise.
- | When upgrading the pump station, the new pump may have a higher rotational speed or an impeller with a higher number of impeller blades than the old pump. This can cause the excitation frequency of the pump to change, creating a vibration problem where previously there were not any.
- | Older style pumps traditionally used base elbows or fabricated metal stands to mount to the floor. Using these types of stands with new pumps can cause greater vibration in the system, as they do not have enough weight to dampen the pump and motor compared to a properly designed concrete pedestal foundation. Space constraints may also prevent a proper concrete foundation from being used. The tradeoff is a higher vibration level in the system.

Refer to the items mentioned in the "Good pump station" section when upgrading a dry pit pump station to ensure ease of service, troubleshooting and maintenance. Xylem can provide design assistance when working on upgrading dry pit pump stations.

Our engineering and expertise can help evaluate potential problems and provide assistance in trying to resolve them.

## G2

### REDUCING NOISE

Reducing noise in a dry pit pump station can be challenging because most of these stations include multiple sound emitters (pumps, piping and valves), coupled with walls, ceilings and floors of a high sound-reflective material (concrete).

Xylem has identified three different solutions and evaluated the effect they can have on noise reduction in a typical dry pit pump station. The most common sound isolating enclosure consists of a three layer structure constructed of mineral wool layered between perforated sheet metal.

**The following approximations can be stated for this type of enclosure:**

- | Pump Isolation: This method involves creating an enclosure that will completely surround the pump, except where the piping connections are located. Using this type of sound isolation can reduce the sound pressure in a station by 15%. Ensure that the pump motor will not experience excess temperatures due to being enclosed.
- | Pipe Isolation: Pressurized water moving through pipes will transmit sound to the outside environment just as a pump will. Isolate long pipe runs in a similar way as a pump. Xylem estimates that enclosing the pipes in a station will reduce the sound pressure in a dry pit station by 25%.
- | Surface Isolation: The last possibility is to cover the reflective walls and ceiling with a sound reducing covering. This prevents sound from reflecting and creating additive echoes. Covering the ceiling with an excellent sound absorbent material can reduce the sounds pressure by up to 50%, while covering the ceiling and walls can reduce the sound pressure by up to 60%.

It is possible to combine the above options and reduce sound pressure to the greatest extent - up to 80% in a dry pit pump station.

Noise created in the dry pit pump station can be transmitted to the outside environment, which can lead to complaints in industrial or residential areas.

Follow these steps to prevent this from happening:

- | Avoid transmitting noise and vibrations to the weak parts of the build structure via rigid connections of piping, valves, etc.
- | Use rubber bushings or a similar device between piping, supports and weak walls.
- | Avoid open channels, such as ventilation ducts, out of the room with the source of the noise.

**If you would like Xylem to estimate the sound pressure reduction that could be possible in your existing dry pit station, please provide us with the following information:**

- | Size of the dry pit station. (Length x Width x Height)
- | Number of pumps in the station.
- | Material of the walls, floor, and ceiling.

**We can use this information to provide an estimated sound level and calculate the noise reduction that can be achieved with the above methods.**

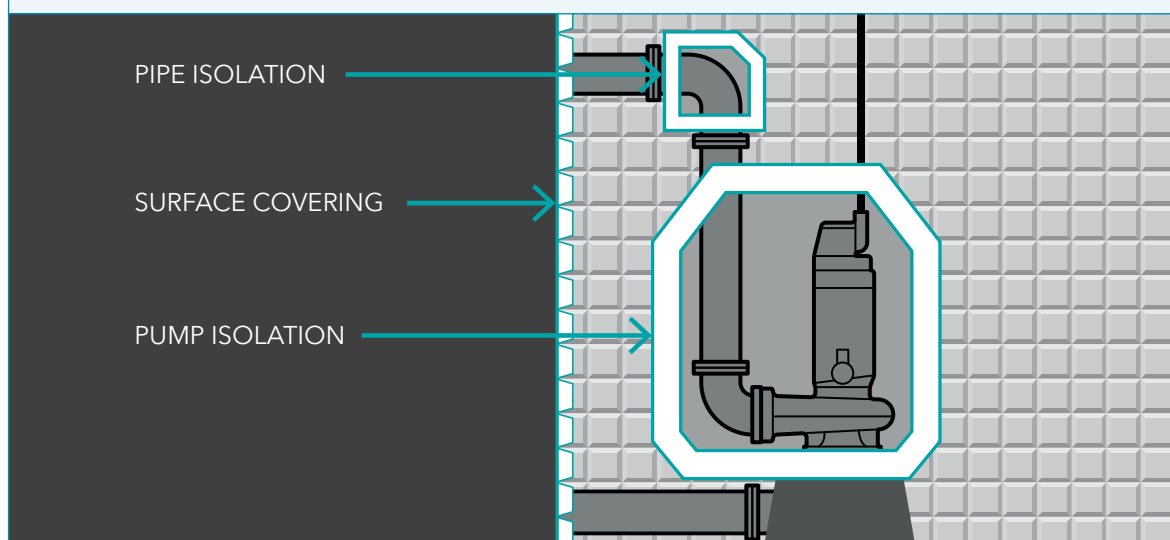

## H | MOTOR SURFACE TEMPERATURE

Because water is a much more efficient cooling environment than air, using submersible pumps in a dry pit environment can have a higher skin temperature compared to a traditional air-cooled motor with a fan. It is important to understand when and where motor heat presents a potential safety risk so that proper education and notification can be posted on the equipment.

There are four common methods used for cooling a submersible motor:

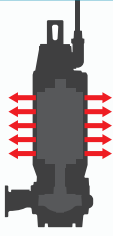
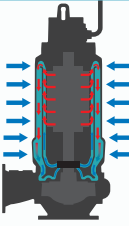
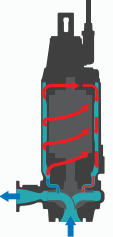
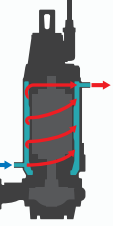
	<p><b>Direct surface contact with immersed fluid or air.</b>                  Direct cooled motors are of highest concern for personal health and safety. The pump can become hot enough to burn when running in air, whilst it can run very cool submerged in a wet well. In general, direct air-cooled motors are found in sizes under 7.4kW. Line started permanent magnet motors (LSPM) can be used in smaller air-cooled motors to reduce the skin temperature. The use of permanent magnets increases the efficiency of the motor which results in less heat being generated.</p>
	<p><b>Closed loop cooling system with a fluid circulating around the motor.</b>                  Closed loop cooling systems generally have a low skin temperature. Most of the heat is transferred from the motor through the motor/pump interface and therefore to the pumped media. Closed loop cooling systems that use oil-filled motors are an exception and can produce exceptionally high skin temperatures. It is important to know what type of closed loop cooling system a submersible pump is equipped with.</p>
	<p><b>Open loop cooling system with the pumped media circulating around the motor.</b>                  Open loop cooling systems also tend to have a low skin temperature. In this type of system a portion of the pumped media is passed through the motor and then back into the pump. This type of system is normally found on larger submersible pumps.</p>
	<p><b>Closed loop cooling system with an external source of fluid. This system may or may not use a heat exchanger.</b>                  Open loop cooling systems can also be converted to a closed loop system with the use of external cooling water. This could be desired for many specific reasons. Depending on the nature of the cooling water system, an external heat exchanger may be required to keep the motor cooled. The skin temperature will be directly related to the external fluid temperature in this situation.</p>

## I | PRIMING DRY PIT PUMPS

Generally, Flygt pumps are not self-priming. As a result, priming requirements need to be considered for each station. Certain pump station designs can be difficult to prime as no easy methods are available to allow for priming. Because pump priming usually only needs to be done after servicing a pump or in other rare situations, it is usually a manual operation.

**The following list contains some suggestions for including air venting to enable priming of a Flygt pump in a dry pit station:**

- | Use a double acting sewage air release and vacuum valve. Plumb the outlet to a drain in case sewage leaks from the valve.
- | Include a simple isolation valve that is manually opened to release air. Plumb the outlet to a drain to help keep the station clean.
- | Add a simple recirculation line returning to the sump. This line can be always open (automatic priming) or manually opened (operator controlled priming). Only use an always open line in stations with short run times due to the loss in pump efficiency.
- | Drill a small opening on the inlet suction bell. Please note, evaluate other options before choosing this solution.

Consider an automated priming system for dry pit pump stations that require actual static lift of the fluid and include vacuum equipment to ensure the system is primed. Priming is especially important in self-cleaning trench stations with dry installed pumps, due to the unique geometry and operation of these stations. Ensure the water level is allowed to rise to a height after a cleaning cycle that enables all pumps to have a flooded impeller. Sludge applications have special priming considerations when centrifugal pumps are used. Centrifugal pumps have very limited abilities to “pull” sludge through suction piping. Take care when using centrifugal pumps to make sure that the sludge can freely flow to the pump. Use minimal disturbances in the suction piping to ensure that the sludge can freely flow to the pump. As there will be also an increased NPSH requirement due to the nature of sludge, this will also assist in minimizing any NPSH problems the pump may experience.

Check valve placement is another area that requires special attention. Because air is compressible, the pump will not be able to force open a check valve in certain situations. This is especially true in applications with short distances between the pump and check valve, and in applications containing check valves that have very high static heads on their downstream sides. If the two situations are combined without some method of manual or automatic priming, it may be very difficult to for the pump to force the check valve open.

The following section discusses the general recommendations for concrete foundations for use with Xylem pumps.

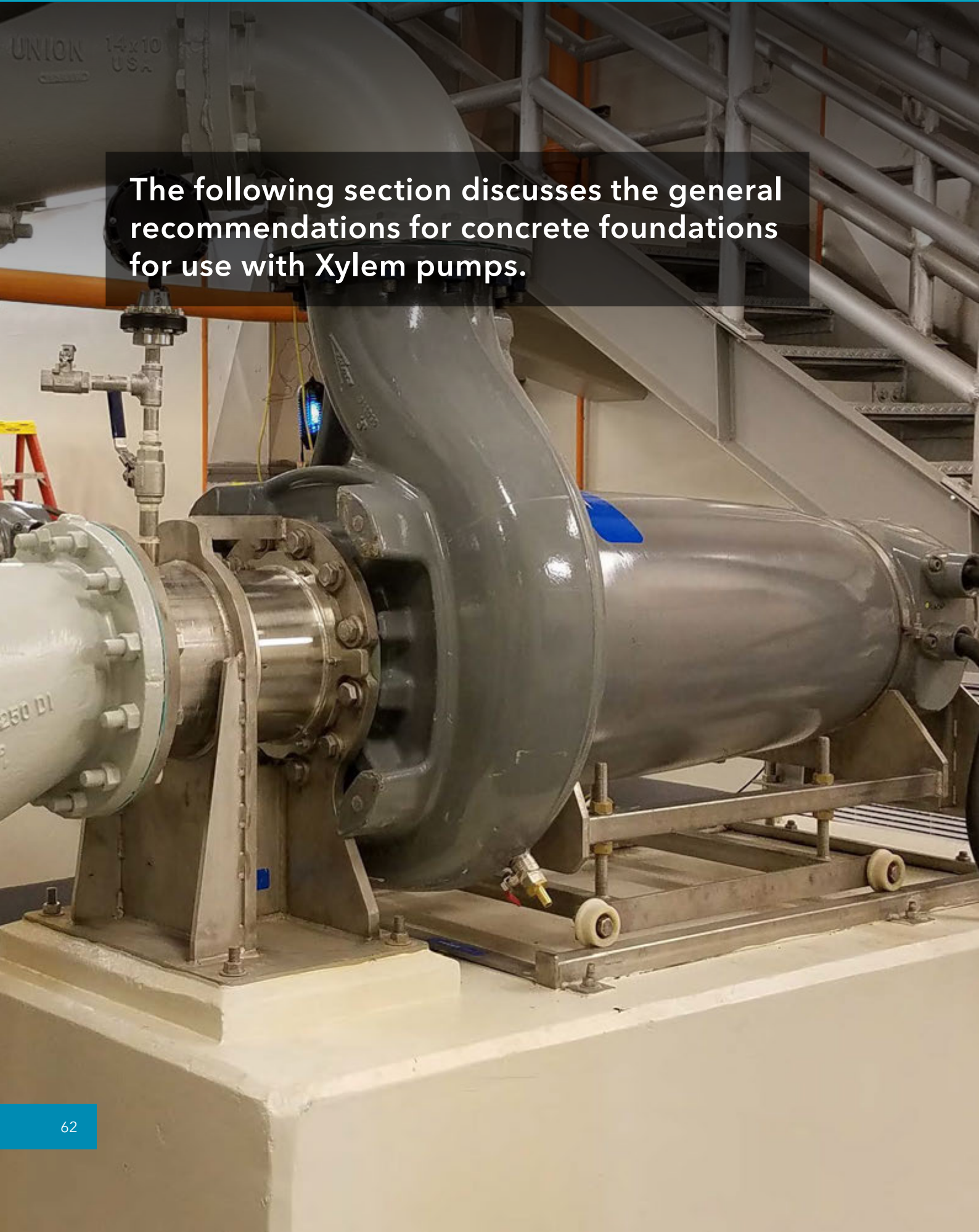

There are many times or situations where these recommendations do not apply. This includes areas where local regulations supersede any of these recommendations and areas where a seismic zone rating is required for installation of equipment. Always check with local authorities regarding what requirements exist for installing equipment in a given locality. A registered civil engineer familiar with the local requirements should always make the final recommendation and design when it comes to civil work such as this.

#### Horizontally Dry Installed Flygt Submersible Pump Example



The above picture illustrates a horizontally dry installed pump with both a service inlet and service sledge and is one example of the type of complete pumping package that needs to be mounted on a concrete foundation.

**Before doing any type of design for a pedestal or a pad concrete foundation, it is advised to do the following:**

- | Reference the dimensional drawings for the pumping equipment that will be installed to get a complete overview of the size and weight of the equipment.
- | Review the installation and operation manual for the pumping equipment and accessories so that a complete understanding of the requirements of the system can be understood for installation, operation and servicing of the equipment.
- | Review the recommendations within this section of this guide.
- | These recommendations try to include best practices and items that should not be forgotten when working with foundation design.



## A | GENERAL RECOMMENDATIONS FOR CONCRETE PEDESTALS OR PADS

The following are general recommendations that can be used for either concrete pads (horizontally or small vertically installed pumps) or concrete pedestals (large vertically installed pumps).

- | Reinforce concrete pedestals and pads and align these reinforcements with the floor rebar when possible.
- | Keep the overall pedestal or pad height (concrete and grout) as low as possible, but still allow for proper piping alignment and clearance of suction piping with the floor.
- | Ensure pedestal or pad length and widths are sufficient to meet civil engineering design standard and local codes.
- | Ensure pedestal or pad length and widths are large enough to encompass the entire required mounting area of the pump mounting system and allows for the edge distance required by the anchoring system chosen. Detailed requirements of the pump mounting system can be found in the pump dimensional drawing sheet.
- | Arrange the opening between pedestals to allow for proper clearance of the inlet flange at the pump suction. For vertically installed pumps, ensure the inlet elbow has the required clearance.
- | Consider access to pump mounting bolts and if used, service inlets and/or carts/sleds.
- | Make sure the foundation and concrete are of adequate strength to support the weight of the pump with its accessories, the weight of the liquid passing through it and the forces generated by the pump. If horizontally installed pumps are on rails/sleds, be aware that the motor can shift to another section of the foundation.
- | Consult a registered civil engineer for specific design details.

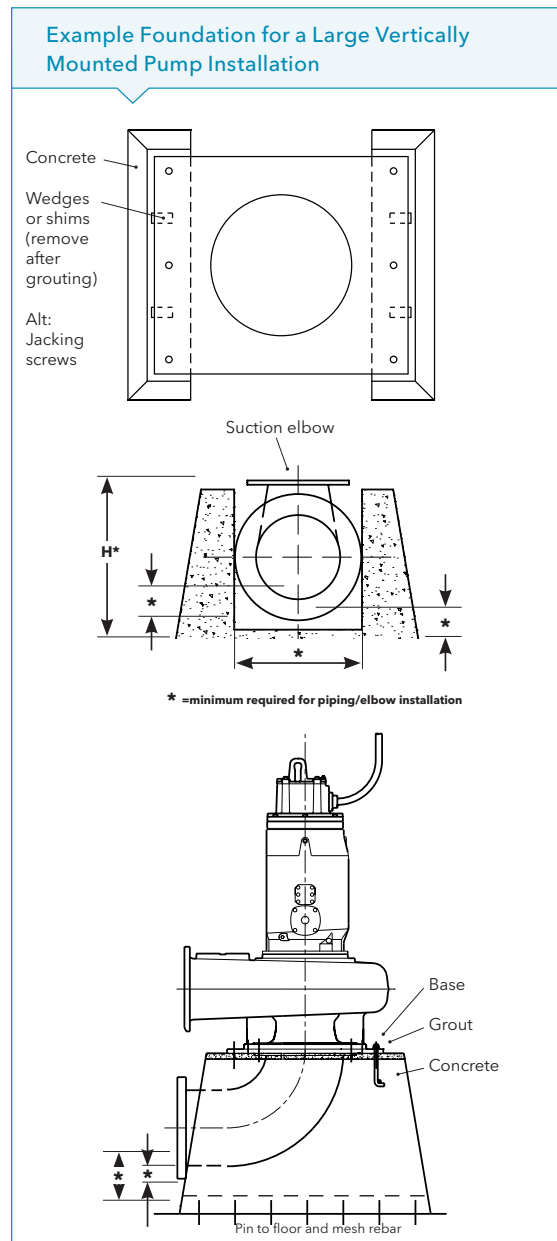

## B | ANCHOR RECOMMENDATIONS

- | Chemical anchors can be used to anchor Xylem pumps, but the bond often degrades over time and is more elastic than a mechanical anchor. Mechanical cast-in-place anchors meshed with re-bars in concrete are the most robust alternative, and they are especially recommended for large dry vertical pump installation.
- | Protect the anchor's length required for pre-stressing to prevent bonding (heat shrink, wax or heavy grease) with the concrete or grout.
- | Apply the specified torque in three steps: 33%, 66% and 100% of max torque. At each step, torque all bolts before starting the next step, in an opposing pattern.
- | Check the anchor bolt torque for pre-stress relaxation after completion of the initial pump start up test runs. If pre-stress relaxation has occurred, re-apply the torque using the method described above. If correction was required after start-up test runs, check again after 50 hours of pump operation and repeat this process every 50 hours of operation until pre-stress relaxation stops.

Installation Using Chemical Epoxy Anchors

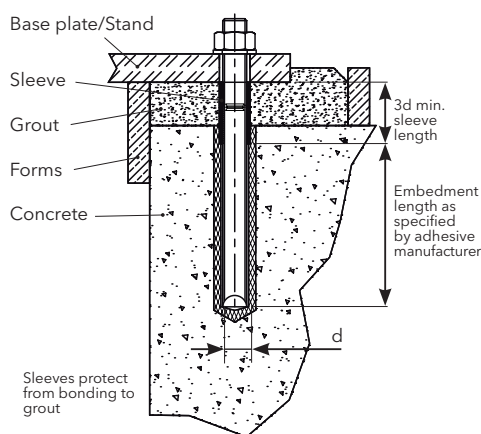

Installation Using J/Cast-in-place anchors

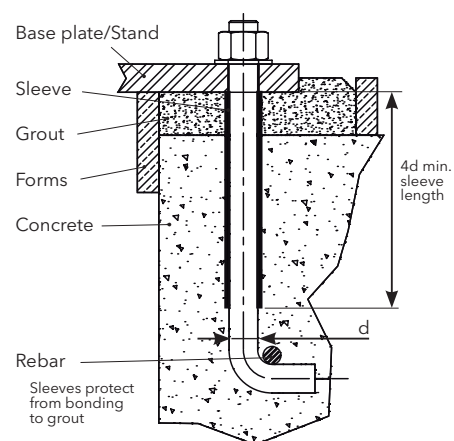

## C | PUMP ATTACHMENT

Ensure contact exists along the entire length of the base, rails and /or stands to the concrete foundation. Do not use local leveling devices, such as washers, as this can make the assembly partly unsupported. Follow the steps below if leveling and grouting are needed:

- | Check the installation, operation and maintenance manual for detailed instructions on what is required for installing your specific pump and accessories. As different pump size groups have different types of requirements, it is import to familiarize yourself with the equipment to be installed.
- | Install and level the base, rails and/or stands only (without the pump) using steel blocks and leveling wedges. Coat steel blocks, leveling wedges and anchor bolts with light oil immediately prior to leveling and grouting.
- | Pre-stress all anchors (lightly torque) after leveling and prior to grouting. Re-check level prior to grouting.
- | Do not use leveling nuts on the anchors since the anchor will not be properly pre-stressed into the concrete/grout foundation.
- | Keep leveling shims and blocks as small as possible and place them as far as possible from the anchors so the voids do not impair the grout strength after the shims' removal. An alternate solution involves adding threaded holes for jackscrews in the plate (not standard) and using the jackscrews for leveling. Remove leveling equipment and fill the voids with grout to allow full support of the base, rails and/or stands.
- | Refer to the grout supplier's recommendations regarding the thickness and application of grout.
- | Pour the grout around the base, rails and/or stands to approximately ½ of the thickness so that some head is developed, and the grout will contact all areas under the assembly without voids.
- | Provide blockouts at all leveling positions to allow for removal of leveling equipment after grout has cured. Fill voids with grout after leveling equipment is removed.
- | Include a 45-degree chamfer at the final elevation of the grout.



CONTACT YOUR LOCAL XYLEM REPRESENTATIVE IF YOU REQUIRE DETAILED INFORMATION.

## Leveling and Ground Details

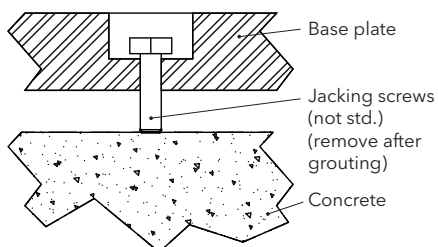
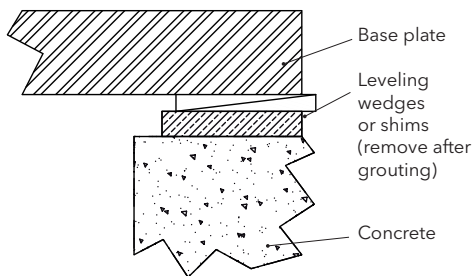
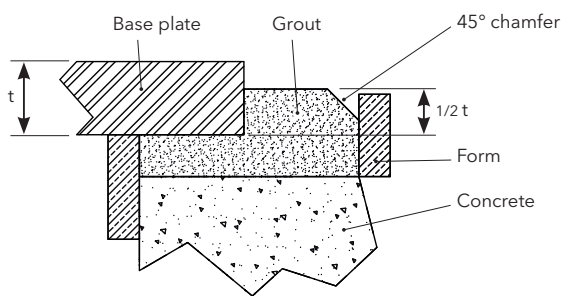

Proper pump sump design is crucial in order to achieve an optimal inflow to the pumps.



These next few sections are intended to help you incorporate Flygt submerged propeller pumps and axially installed centrifugal pumps into different pumping applications.

**Ensure the following important design requirements are being met:**

- | Implement a uniform approach flow to the pumps
- | Prevent pre-rotation under the pumps
- | Prevent significant quantities of air from reaching the impeller or propeller
- | Facilitate the transport of all settled and floating solids

The Flygt standard pump station design can be used as is, or with appropriate variations upon review by Flygt engineers.

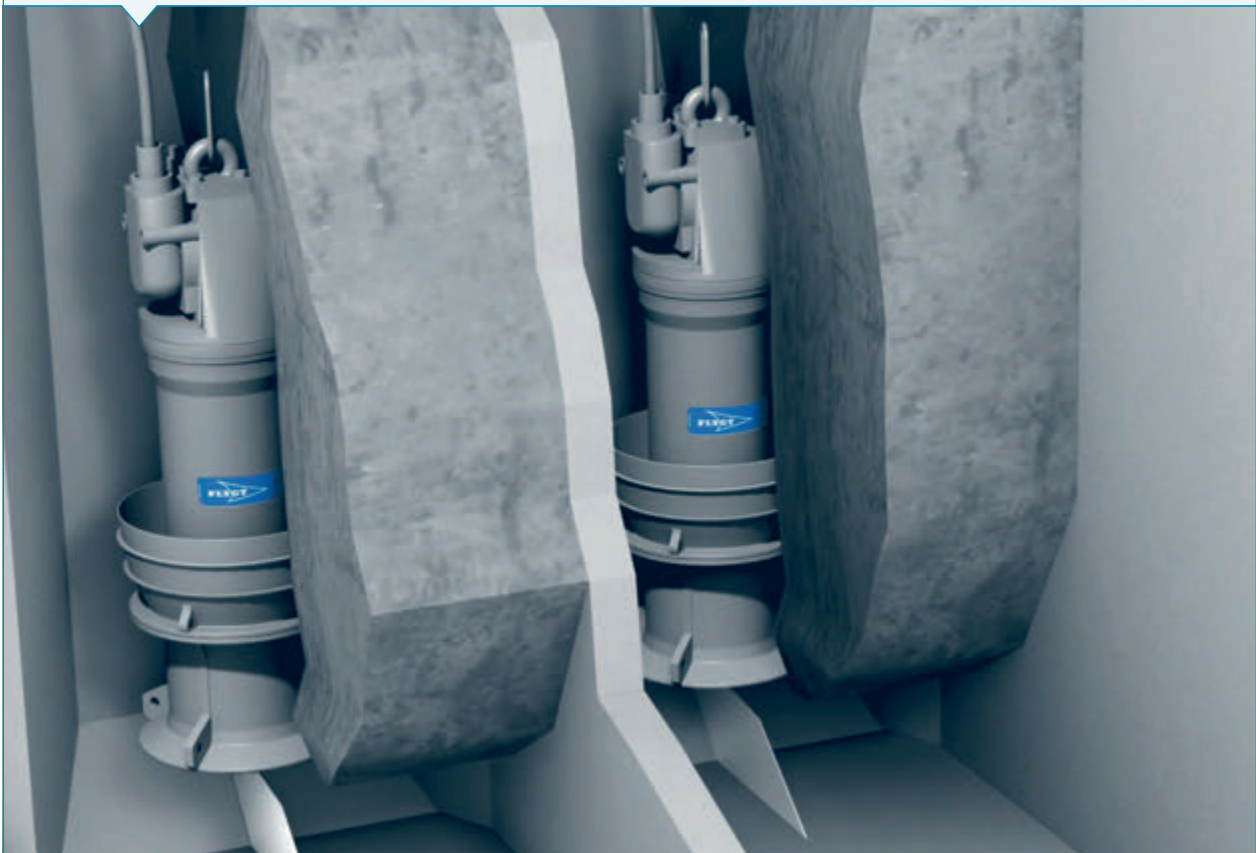

## A | FLYGT PROPELLER (PL) AND MIXED FLOW (LL) PUMP INTRODUCTION

**Flygt submersible vertically installed propeller pumps and mixed flow pumps have been used in a wide variety of applications where large volumes of water have to be pumped, including:**

- | Stormwater stations
- | Flood control and pump gate stations
- | Sewage treatment plants
- | Land drainage and irrigation systems
- | Fish farms
- | Power plants
- | Shipyards
- | Amusement parks

**Flygt submersible PL and LL pumps offer the following important advantages:**

- | Compact motor and pump unit
- | No separate lubrication system
- | No external cooling system
- | Low operating sound level
- | Quick connection and disconnection for installation and inspection
- | Minimal station superstructure
- | Simple pipe work

Flygt PL and LL pumps are usually installed in a vertical discharge tube resting on a support flange incorporated in the lower end of the tube. Anchoring is not required because the weight of the pump and hydraulic thrust is sufficient to keep it in place. The pumps are equipped with an anti-rotation gusset, which provides the simplest possible installation - the pump is lowered into the discharge tube by a hoist or crane and retrieved just as easily.

These pumps also have the possibility to be installed horizontally, inclined, and even floating. For these alternative installations, additional considerations need to be taken into account regarding the details of the installation to assure a reliable and easy access to the pumps.

**Please contact your local Xylem representative for more information and support on these types of installations if they are the most appropriate for your site.**

## B | GENERAL CONSIDERATIONS FOR PUMP STATION DESIGN FOR PL AND LL PUMPS

Due to the nature of axial and mixed flow pumps, how the water flows to the pumps is of crucial importance. This is because axial and mixed flow pumps are greatly affected by adverse hydraulic conditions.

Ideally, the flow at the pump inlet should be uniform and steady, without swirl, vortices or entrained air.

### **Use the following considerations to inform your pump station design:**

- | Non-uniform flow at the pump intake can cause pulsating loads on the propeller blades, resulting in noise, vibration and a reduction in efficiency.
- | Swirl in the intake can change the head, flow, efficiency and power in undesirable ways. It can also increase the risk of vortex formation.
- | Vortices that contain a coherent core can cause discontinuities in the flow and lead to noise, vibration and local cavitation. Vortices emanating from the free surface can become sufficiently powerful to draw air and floating debris into the pump.
- | Entrained air can reduce the flow and efficiency, resulting in noise, vibration, fluctuations of load and consequent physical damage.

Experience with designs already in use provides valuable guidelines for the design of multiple pump stations. Adaptations of existing and well-proven designs can often provide solutions to complex problems, even without model tests. Xylem has extensive experience based on many successful projects, and the services of our qualified engineers are always available. For special applications beyond the scope of this manual, please contact your local Xylem representative for assistance.

Multiple pump systems provide greater capacity, operational flexibility and increased reliability, which is why pump stations are usually equipped with two or more pumps. Transition to the sump whether diverging, converging or turning – should result in nearly uniform flow at the sump entrance. Prevent obstacles that generate wakes from interfering with the approaching flow and avoid high velocity gradients, flow separation from the walls and entrainment of air.

In pump stations, there are three significant hydraulic zones: inlet, forebay and the pump bay.

## C | ZONES OF AXIAL PUMP STATIONS

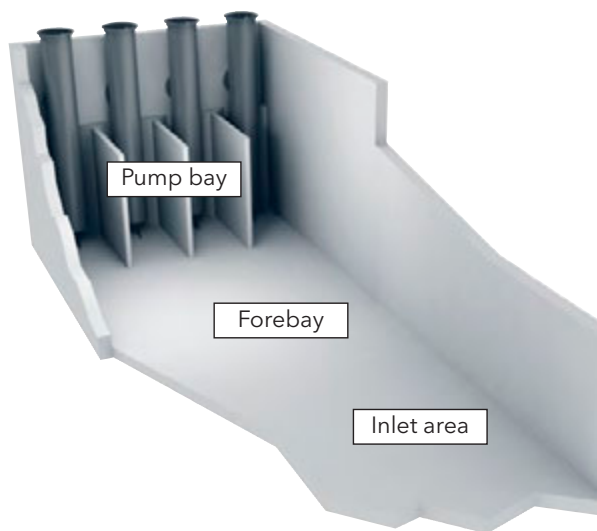

### C1

#### INLET

An inlet conveys water to the pump station from a supply source such as a culvert, canal or river. An inlet typically has a control structure such as a weir or a gate.

### C2

#### FOREBAY

The forebay guides the flow to the pump bays and ensures that flow is uniform and steady. Because the inflow to each pump bay should be steady and uniform, the design of the forebay feeding the individual modules is critical and should follow guidelines in this manual.

The design of the forebay depends on the water approach to the pump station. This approach is commonly encountered as parallel with the sump centerline, the preferred layout, or perpendicular to the sump centerline.

### C3

#### PUMP BAY

In practice, only the design of the pump bay can be standardized for a given pump type. A properly designed bay is a prerequisite for optimal flow approach to the pumps, but it does not necessarily guarantee correct flow conditions. A bad approach to the pump bay can disturb the flow in the pump intake. As a rule of thumb, the approach velocity to the individual pump bays should not exceed 0.5m/s. The dimensions of the bay's individual pump bays are a function of pump size and the flow rate which are given in the following sections.

## D | INLET CONSIDERATIONS

How the water approaches the pump station (the inlet) is of utmost importance to how the pump station will need to be designed. The next two items cover the main ways water is brought to an axial pump station.

### D1

#### FRONT WIDE INLET TO THE STATION

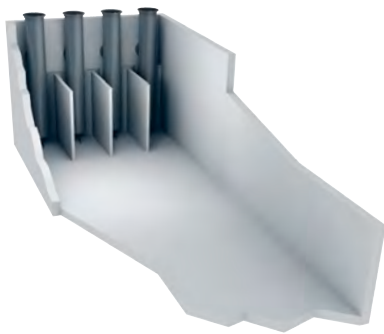

When water approaches the station from a wide supply source such as a culvert or canal, the pumps should be placed symmetrically to the inlet centerline without changing direction of the approaching flow. If the width of the inlet is less than the total width of the pump bays, the forebay should diverge symmetrically. The total angle of divergence should not exceed  $20^\circ$  for the Open Sump Intake Design or  $40^\circ$  for the Formed Intake Design. The bottom slope in the forebay should not be larger than  $10^\circ$ . If these parameters cannot be met, flow direction devices should be used to improve the flow distribution. Such arrangements and more complex layouts should be investigated using model tests and conducting CFD studies in order to arrive at suitable designs.

### D2

#### HIGH FRONT INLET, HIGH SIDE INLET OR LOW SIDE INLET TO THE STATION



When the inlet to the station is located at higher level or perpendicular to the axis of the pump bays, use an inlet chamber or overflow-underflow weir to help redistribute the flow. A substantial head loss at the inlet area is required to dissipate much of the kinetic energy from the incoming flow. Alternatively, baffle systems can be used to redirect the flow, but computational and/or model tests are then required to determine their correct shape, position and orientation. Ensure there is sufficient distance between the weir or baffles and the pump bays to allow eddies to dissipate, and entrained air to escape, before the water reaches the pump inlet.

## E | PUMP BAY DESIGN VARIATIONS

### E1

#### PUMP BAY DESIGN VARIATIONS: OPEN SUMP INTAKE DESIGN



This intake design is most sensitive to non-uniform approaches. If used for more than three pumps, the length of the dividing walls should be at least  $2/3$  of the total width of the sump.

If flow contraction occurs near the sump entrance because of the presence of screens or gates, the sump length should be increased to  $6D$  or more, depending on the degree of contraction. See [page 94](#) and [95](#) for dimensional information.

The open sump intake design includes flow straightening vanes (splitters) that alleviate the effects of minor asymmetries in the approaching flow. The minimum required submergence of the pump inlet with the open sump intake design is a function of the flow rate, the pump inlet diameter and the distribution of the flow at the approach to the pump. Minimum submergence diagrams are shown in a later sub-section, see [page 62](#). Each diagram has three curves for various conditions of the approaching flow. Because vortices develop more readily in a swirling flow, more submergence is required to avoid vortices if the inlet arrangement leads to disturbed flow in the sump.

## E2

### PUMP BAY DESIGN VARIATIONS: ENCLOSED INTAKE DESIGN



The enclosed intake design is the least sensitive to disturbances of the approaching flow that can result from diverging or turning flow in the forebay, or from single pump operation at partial load.

Therefore, the enclosed intake design is nearly always the preferred choice for stations with multiple pumps with various operating conditions.

The enclosed intake design can be constructed in either concrete or steel. The intake reduces disturbances and swirl in the approaching flow. The inclined front wall prevents stagnation of the surface flow, and geometrical features of the intake provide smooth acceleration and turning as the flow enters the pump.

The minimum inlet submergence for this pump bay design can be found under Column S on the recommended dimensions table on [page 94](#).

## E3

### FORMED SUCTION INTAKE (FSI)



The patented Flygt Formed Suction Intake (FSI) is a versatile and easy to use fitting that can be attached to the suction of axially installed pumps. This intake takes the effectiveness of the enclosed intake and removes the need for the detailed civil works necessary with that pump bay design.

Every Flygt axial pump has a FSI already designed to work with it. With manufacturing drawings available, the FSI can be manufactured locally to reduce shipping costs. Please contact your local Xylem representative if you would like additional information on the Flygt formed suction intake.

## F | INSTALLATION ALTERNATIVES

The following examples show possible alternatives featuring Flygt designed installation components. These installation components, described in more detail in the next section, are modular and are able to be put together into many different ways to create a system that fits any site conditions.

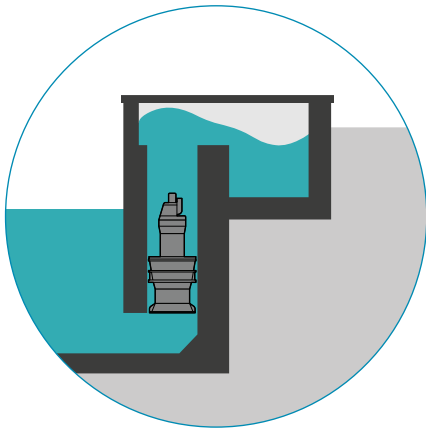

### F1

#### INSTALLATION TYPE 1

This example is suitable for pumping liquid to a receiving body of water with small level variations, or where a short running time can be expected. For this installation type, non-return valves are not required. This arrangement is simple as it involves the least possible number of steel components. The pump is set in a circular concrete shaft with a relatively short tube grouted in place (installation component **D3** as seen on [page 47](#)), which is used as the support structure for the pump. Alternatively, the shaft can have a rectangular cross-section above the discharge column. The shaft extends above the maximum water level in the outlet channel and prevents water from running back to the sump when the pump is shut off.

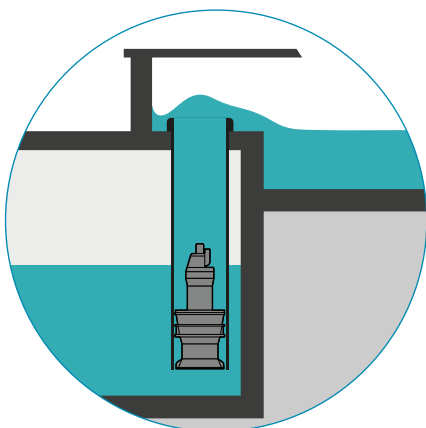

### F2

#### INSTALLATION TYPE 2

An alternative to the concrete shaft is to place the pump in a steel column with a collar that rests on a supporting frame (installation component **D1** as seen on [page 44](#)). The top of the pipe must extend sufficiently above the maximum water level to prevent back-flow from the outlet channel.

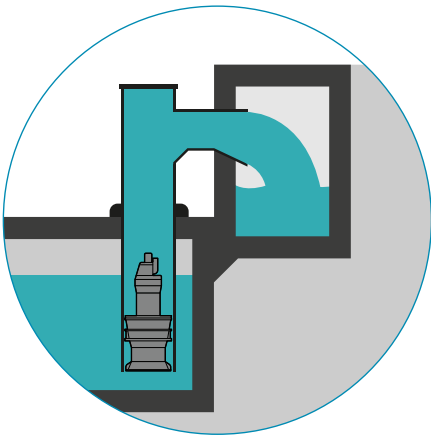

## F3

### INSTALLATION TYPE 3

This arrangement may be used with either a free discharge, when liquid is pumped to a receiving body of water with small water level variations, or with a flap valve, when the water level on the outlet side varies considerably so that the outlet is occasionally submerged. The flow is discharging into a closed culvert through the component **E1** as seen on [page 44](#).

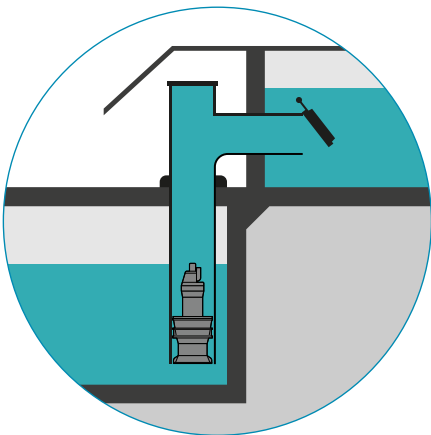

## F4

### INSTALLATION TYPE 4

This arrangement is suitable whenever the liquid is pumped to a receiving body of water with a varying water level. The outlet is equipped with a flap valve to prevent back-flow. When the pump is not in operation, the valve closes automatically, preventing water from running back into the sump. The static head is the difference between water level in the sump and water level at the outlet, and it will be kept to a minimum in this type of installation. Use elbow type **E2** or **E4** for discharging.

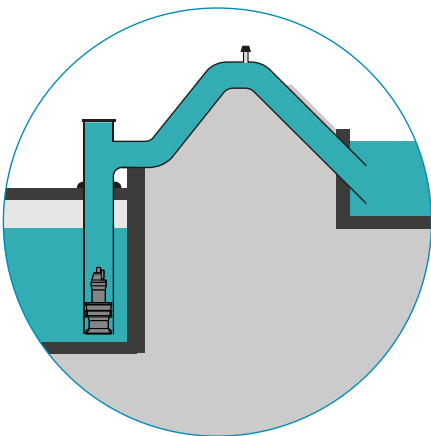

## F5

### INSTALLATION TYPE 5

This easy-to-install elbow construction allows pumps to work in combination with a siphon or discharge line. When the outlet is submerged, a siphon breaking valve is required to prevent back-flow and allow venting at start. This installation keeps the static head to a minimum, since the static head will be the difference between the water level in the sump and the water level at the outlet. Two types of elbows can be used with this station **E2** or **E4**.

## G | INSTALLATION COMPONENTS

The objective in the design and development of installation components is to devise simple systems that offer a wide variety of options and support most situations. These components have been developed to facilitate design work and estimation of costs. Normally, the installation components will be manufactured locally based on Flygt drawings. The drawings can also serve as a basis for the development of new or modified components which better match the local requirements and/or capabilities of the manufacturing facilities.

**Drawings are available for the following installation components:**

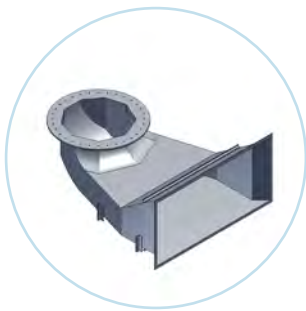

### **FLYGT FORMED SUCTION INTAKE (FLYGT FSI)**

Use the Flygt FSI for very adverse inflow conditions, or when the pump bay dimensions are less than recommended. The main function of the intake device is to preserve an optimal inflow to the pump by gradual acceleration and redirection of the flow toward the pump inlet.



### **COLUMN BRACKET (B)**

Use the column bracket if the free unsupported length of the column pipe exceeds 5 times the pipe diameter.



### **COVER (C)**

This is a cover for discharge elbows (E1 and E2).

## VERTICAL DISCHARGE COLUMN (D)

The vertical discharge column is the component in which the pump is set. Depending upon the depth of the station, the installation may consist of one part (D1) or several parts joined together by flanges (D2), or it may consist of a short tube prepared for grouting in concrete (D3).



D1



D2

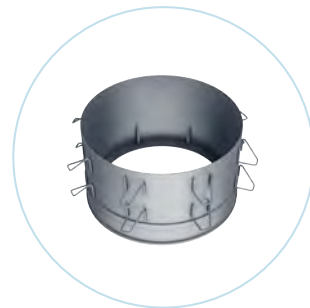

D3

## DISCHARGE ELBOWS (E)

Elbows are available with rectangular exit flange (E1). Discharge elbows with circular exit flanges (E2, E3 and E4) are also available. For simple flooded discharge configurations E5 can be used.

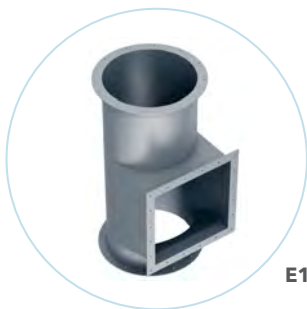

E1

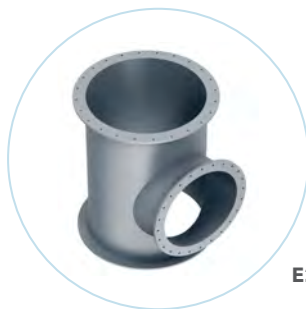

E2

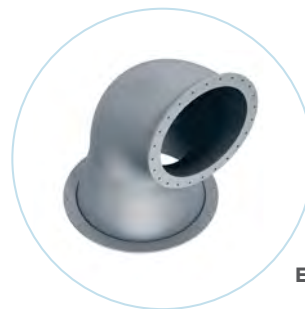

E3



E4

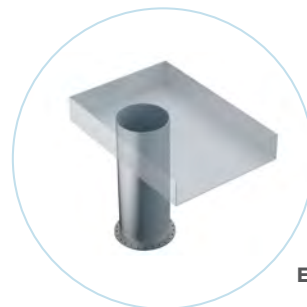

E5

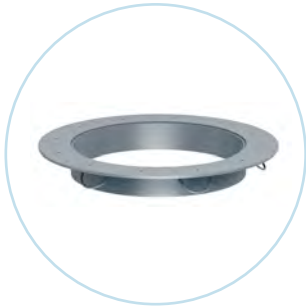

### SUPPORTING FRAME (F)

A frame for suspending the discharge tube from the floor.

## H | CABLE PROTECTION AND SUSPENSION FOR TUBE INSTALLED PUMPS

Proper cable protection and suspension are essential for trouble-free operation of tube-installed submersible pumps. Cable suspension and protection requirements become more stringent with longer cable lengths and higher discharge velocities.

Make sure that the length of the cable allows for easy lift and service of the pump. If the length of the cable does not allow for an easy lift and parking of the unit, the cable or the drive unit might need to be removed for each service round. This adds significantly to service time and cost.

**These basic principles govern good cable protection and suspension practices:**

- | Suspend cables in such a way that they will not come in contact with any surfaces which could abrade the jacket if they move. These include pump and tube components, as well as other cables.
- | Bundle cables together using components that will not cut or abrade the cables.
- | Provide proper strain relief and support at prescribed intervals (depending on length). Spring-controlled tensioning and an integrated "guide wire" are recommended for long cable lengths.

Following these principles will provide the installation with the proper tensioning to reduce movement and wear from the fluctuating fluid flow within the discharge tube.

We offer a variety of cable protection and suspension accessories with recommendations to suit all types of installations and running conditions. Contact your local Xylem representative for information on the best system to meet your needs.



## I | INSTALLATION OF PUMPS

Facilitate pump installation with the aid of the Dock-Lock™ device for easy and safe retrieval of pumps in a wet well. The Dock-Lock consists of a spring-loaded hooking device, a guide line and a tension drum. Because the line guides the hook, there's no time wasted trying to find the pump shackle. The device ensures that the hook actually locks into the shackle. Pumps are retrieved safely, easily and quickly, with minimal maintenance costs.

## J | FLYGT CABLE SEAL UNITS FOR PRESSURIZED TUBES (COLUMN)

Use Flygt cable seal units with Roxtec sealing technology to make a water tight cable entry into a discharge column with water tight cover. The cable seal units are complete with frame, Roxtec cable seal modules, tightening wedge, lubricant and installation manual.

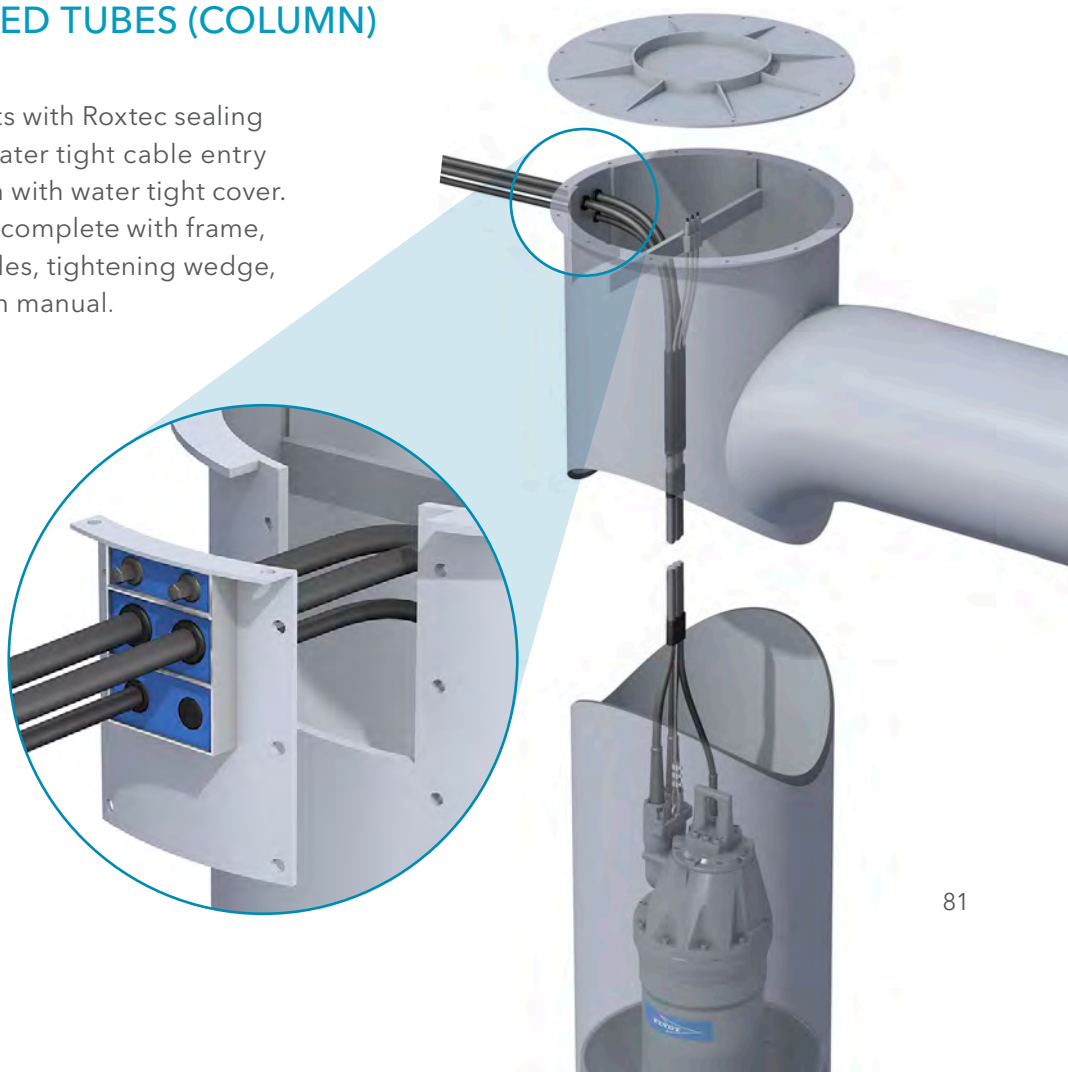

## K | SUBMERGENCE AND LOSS DIAGRAMS FOR PL AND LL PUMPS

### K1

#### PUMP BAY DESIGN VARIATIONS: OPEN SUMP INTAKE DESIGN

The minimum required submergence of the pump inlet with open sump intake design is a function of the flow rate, the pump inlet diameter and the distribution of the flow at the approach to the pump. Each diagram has three curves for various conditions of the approaching flow. Because vortices develop more readily in a swirling flow, more submergence is required to avoid vortices if the inlet arrangement leads to disturbed flow in the sump. Hence, the upper curve in the submergence diagrams is for a perpendicular approach, the middle curve is for the symmetrical approach and the lowest curve for duty-limited operation time (about 500 hours/year). Use the curve appropriate to the inlet situation to determine the minimum water level in the sump and preserve reliable operation of the pumps.

Note: NPSH required for specific duty point may supersede submergence requirements.

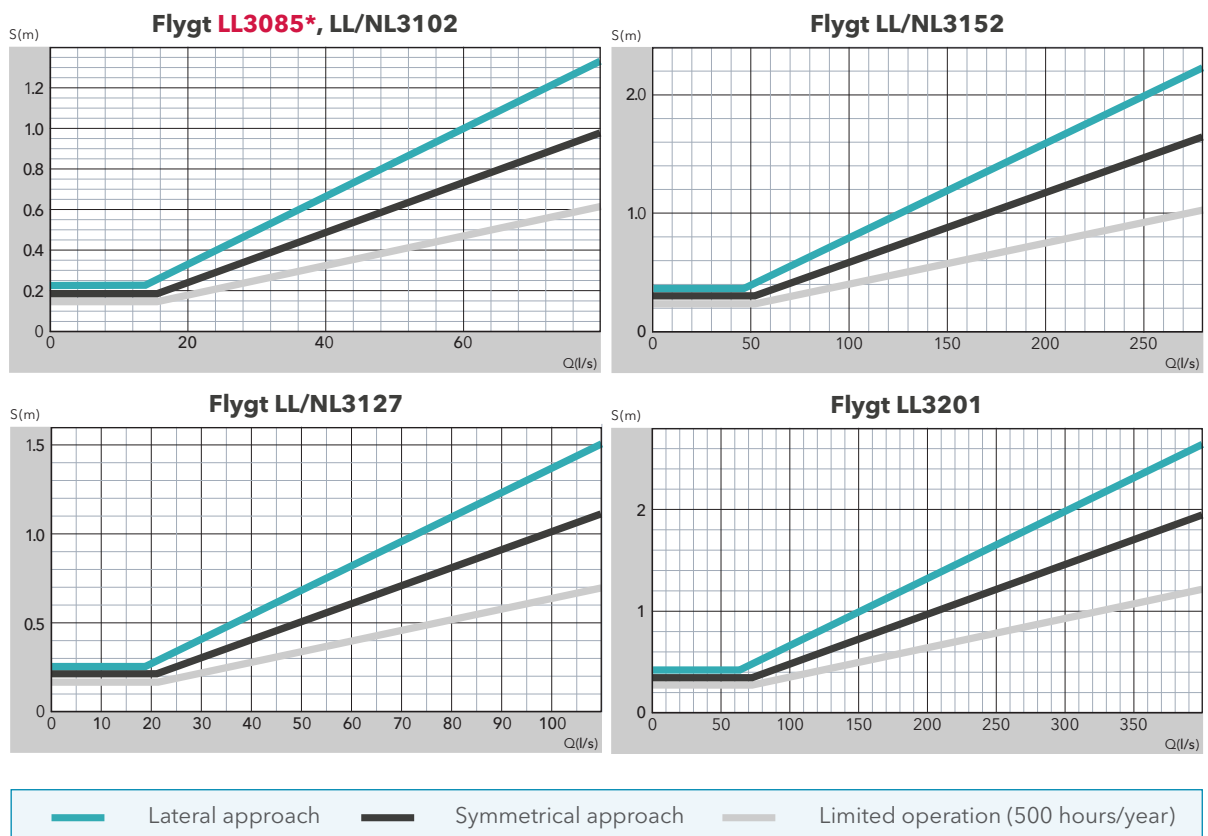

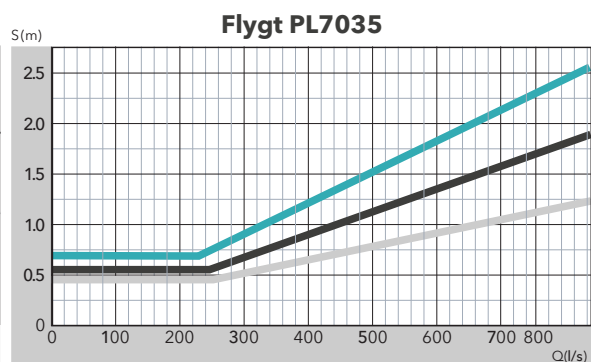
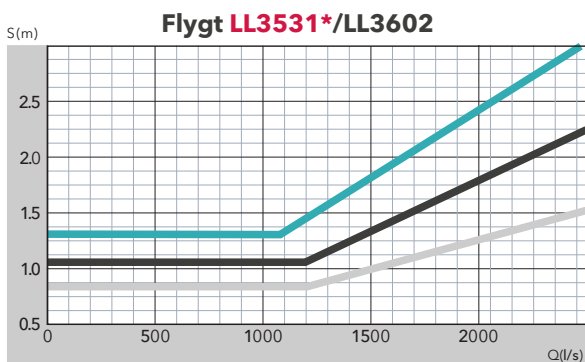
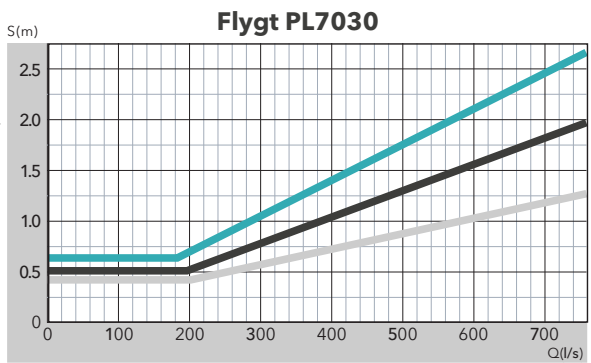
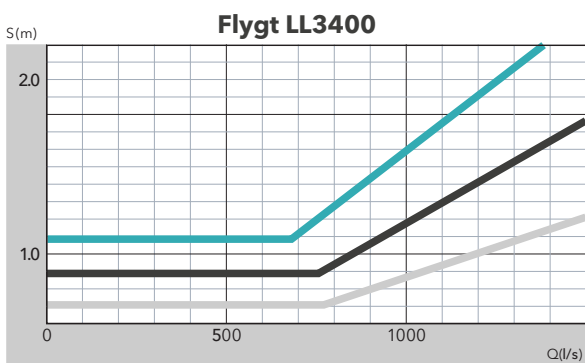
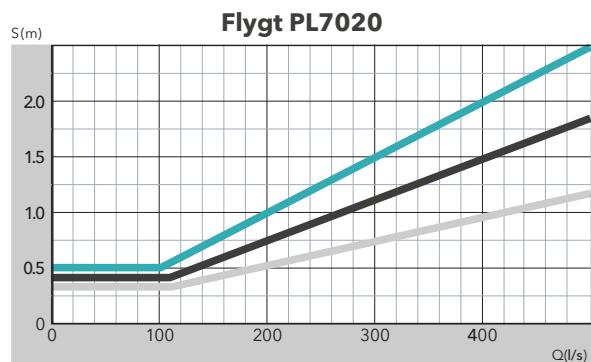
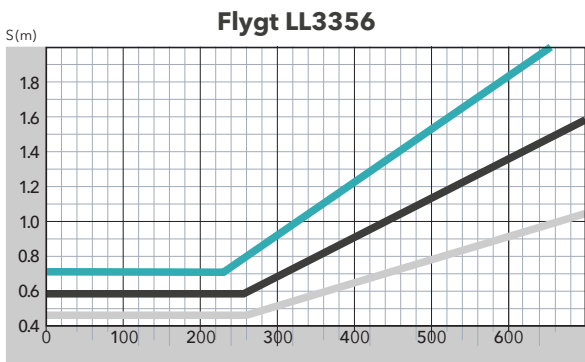
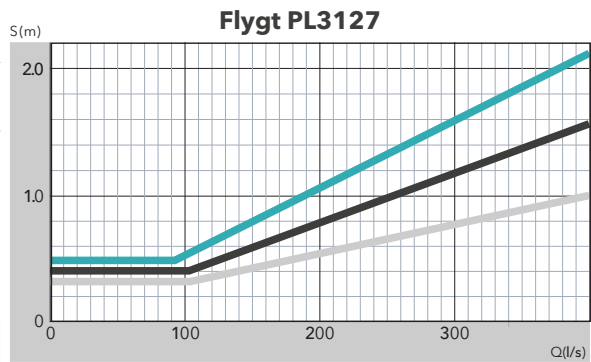
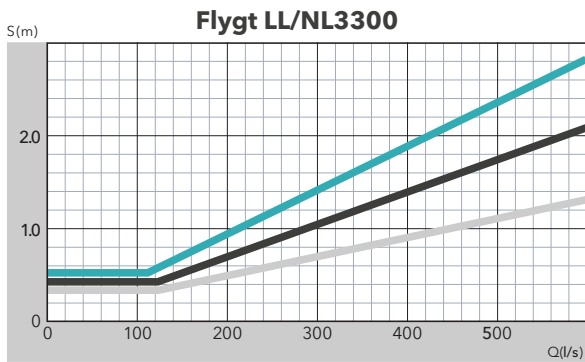

\* THESE PRODUCTS ARE OBSOLETE.

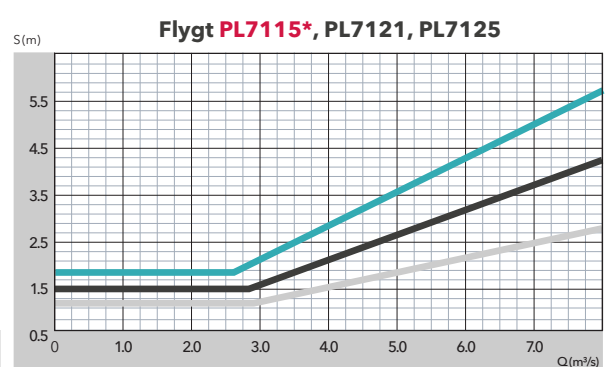
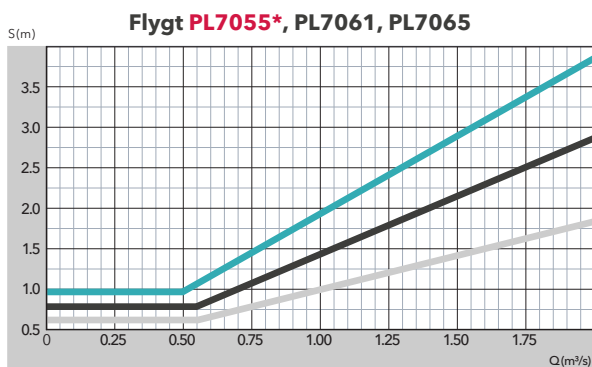
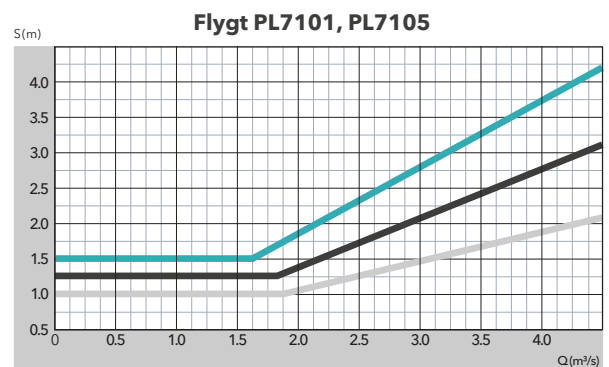
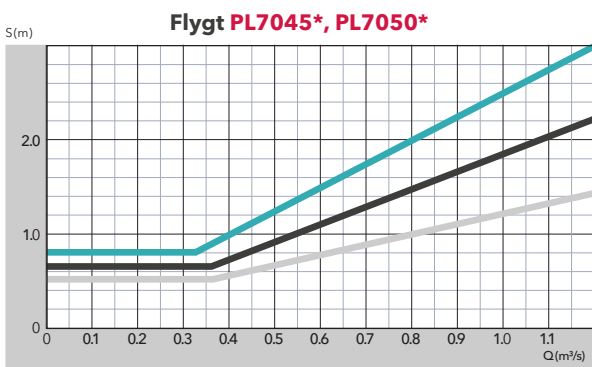
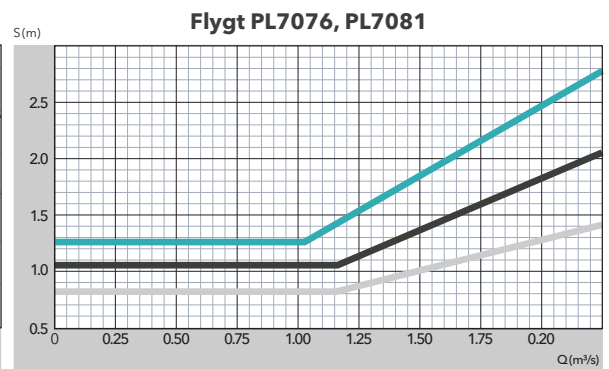
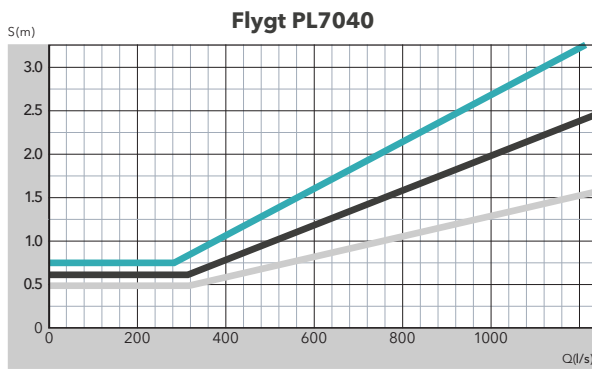

★ THESE PRODUCTS ARE OBSOLETE.

## K2

### HEAD LOSSES DIAGRAMS FOR FLYGT DESIGNED DISCHARGE ARRANGEMENTS

Friction head losses are comparatively small for systems using propeller and axial flow pumps. However, an accurate prediction of losses and the total required head is crucial when selecting the best pump.

Because propeller and axial flow pumps have relatively steep head and power characteristics, an error in predicting the total head can result in a significant change in the power required. A potentially vulnerable situation can arise if head loss is significantly underestimated, which can result in a pump operating against a higher head or delivering less flow and using more power.

Make conservative assumptions when calculating head losses. For all installations described herein, the head losses that must be accounted for occur in the components of the discharge arrangement (friction losses in short pipes are usually negligible). The loss coefficients and the head loss as a function of the flow rate for Flygt system components are shown in the diagrams. For system components not covered by this document, obtain loss coefficients from their manufacturers or appropriate literature.



# Recommendations for Axial Pump Stations

400 mm Installation pipe inner diameter (D)  
Flygt PL7020

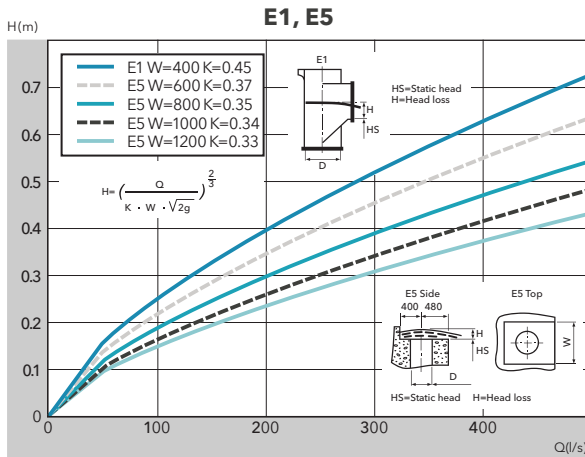

500 mm Installation pipe inner diameter (D)  
Flygt PL7030

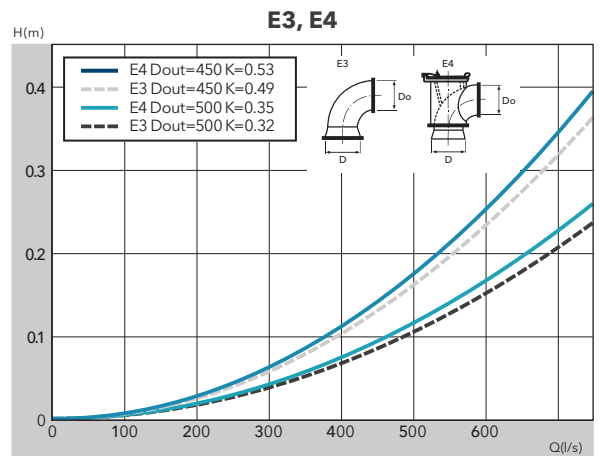
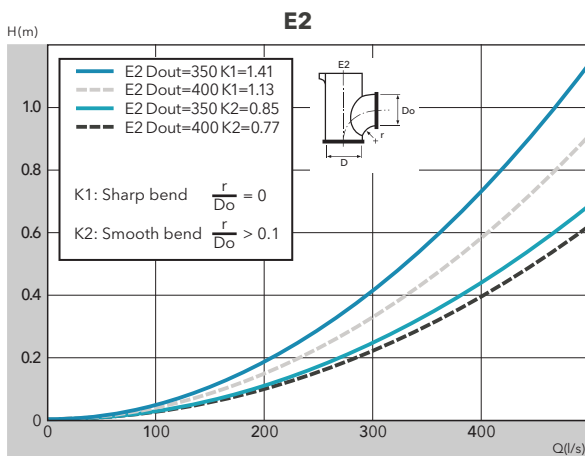
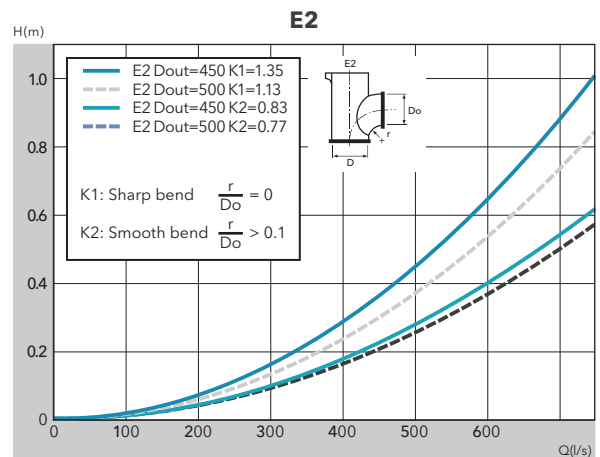
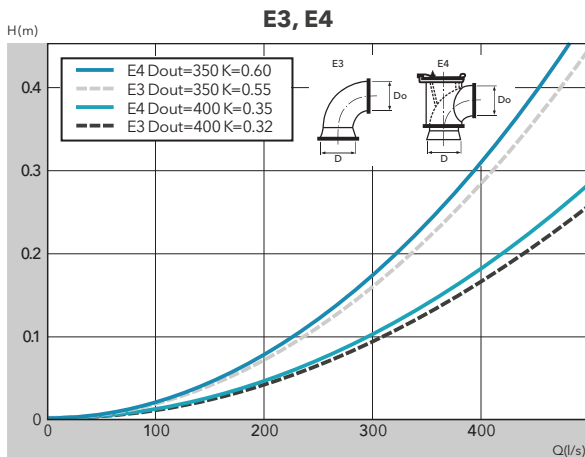
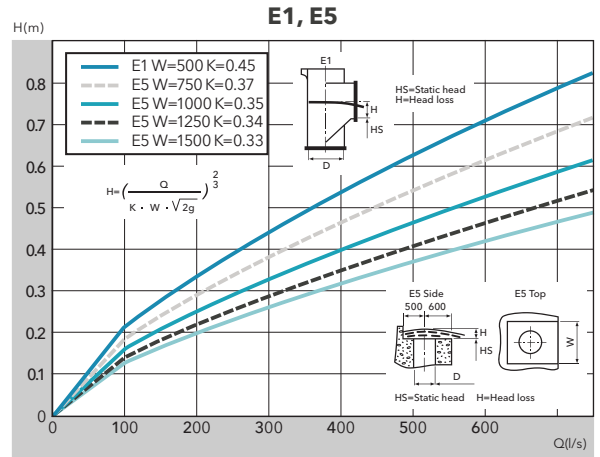

550 mm Installation pipe inner diameter (D)  
Flygt PL7035

600 mm Installation pipe inner diameter (D)  
Flygt PL7040

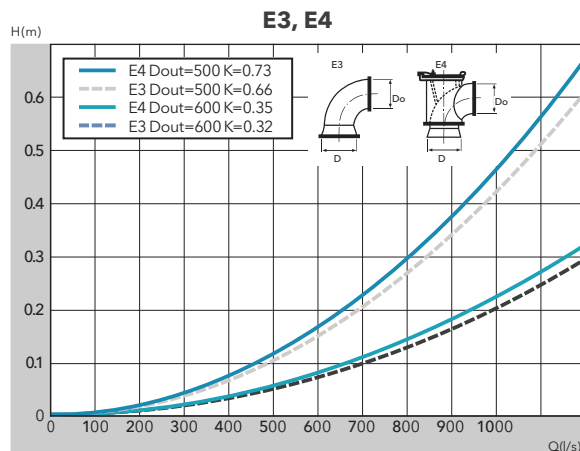
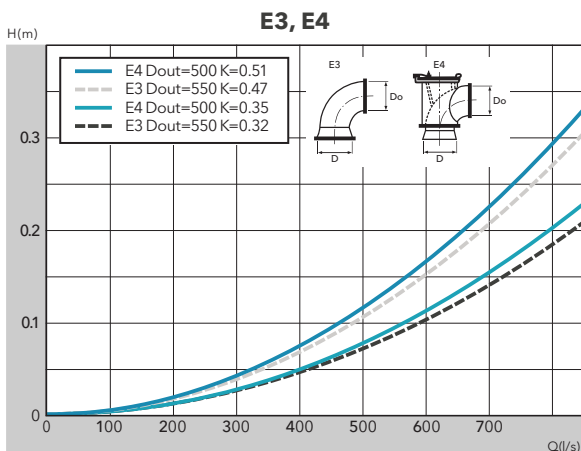
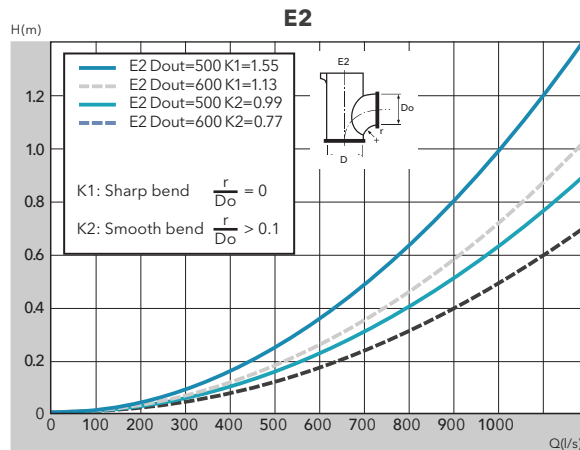
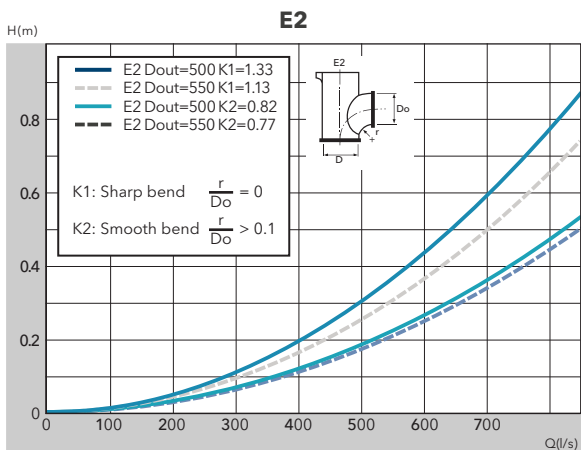
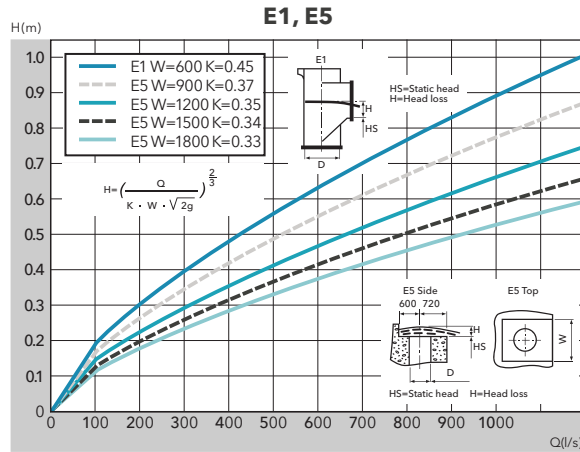
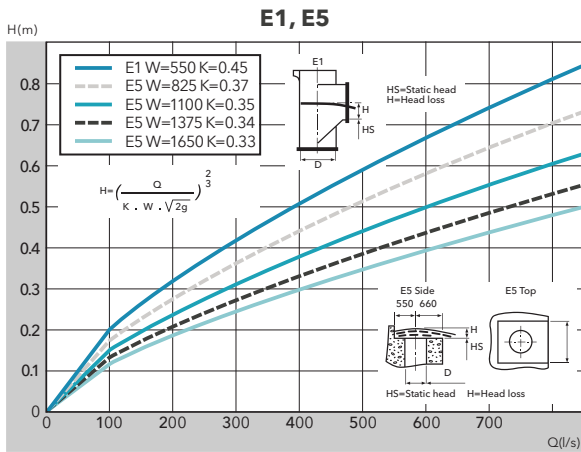



# Recommendations for Axial Pump Stations

700 mm Installation pipe inner diameter (D)  
**Flygt PL7045\*, PL7050\***

800 mm Installation pipe inner diameter (D)  
**Flygt PL7055\*, PL7061, PL7065, LL3356**

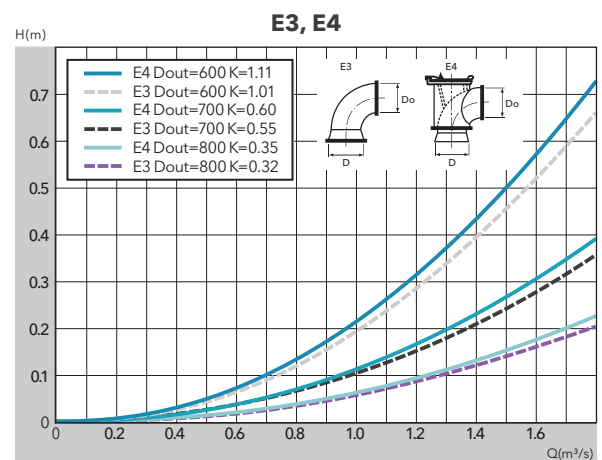
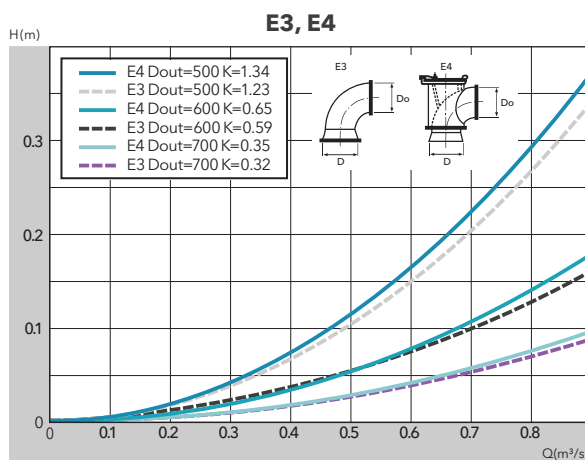
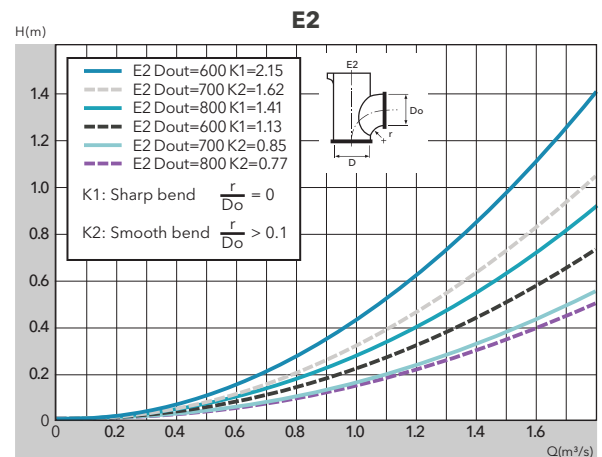
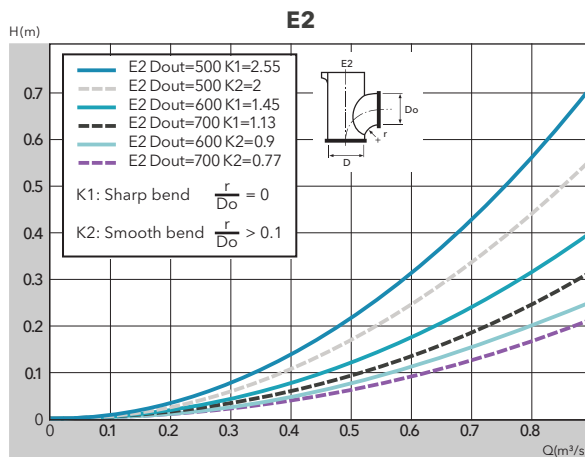
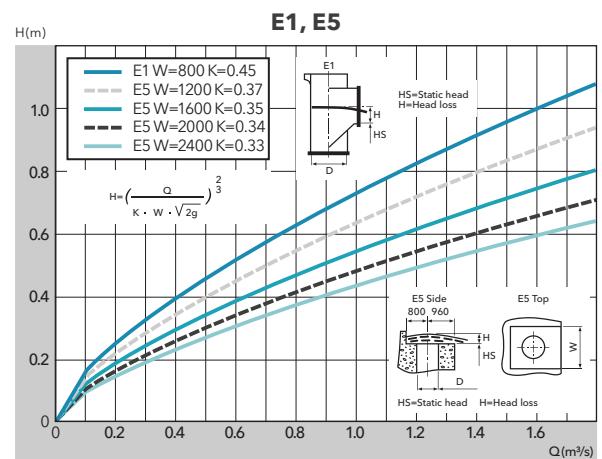
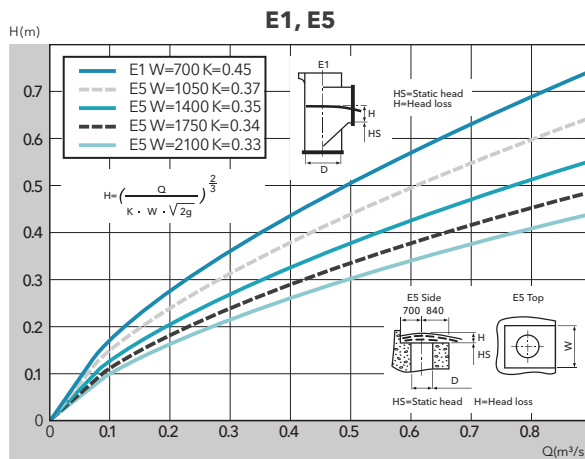

THESE PRODUCTS ARE OBSOLETE.

900 mm Installation pipe inner diameter (D)  
Flygt LL3400

1000 mm Installation pipe inner diameter (D)  
Flygt PL7076, PL081

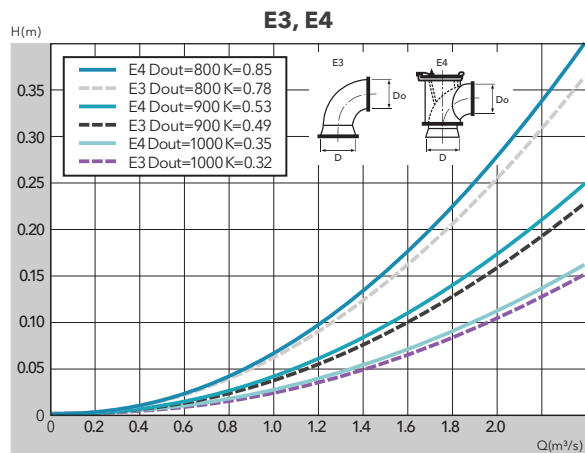
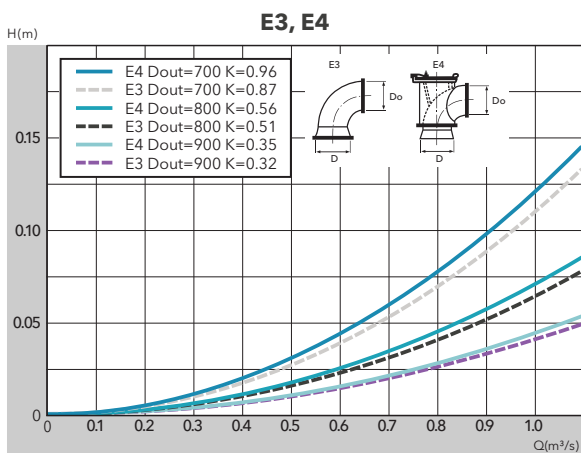
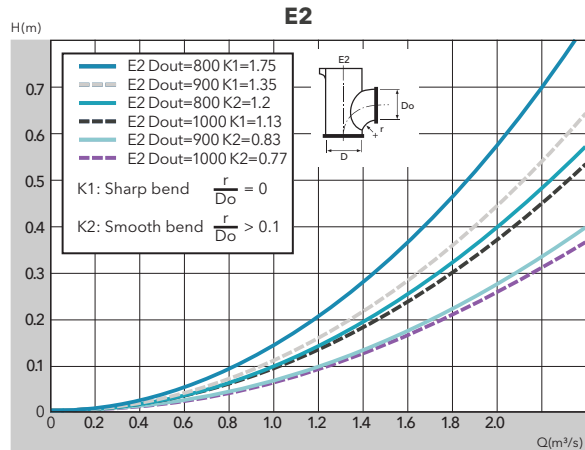
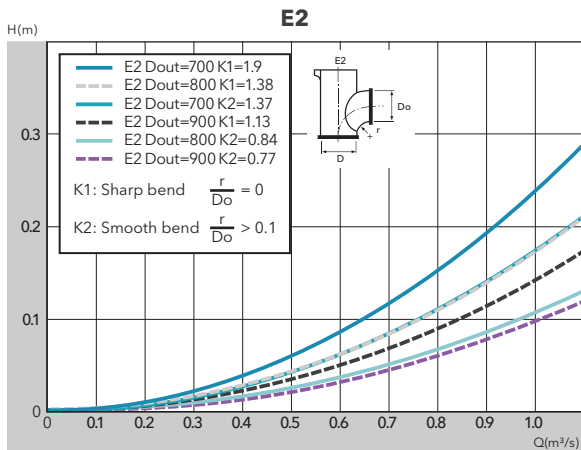
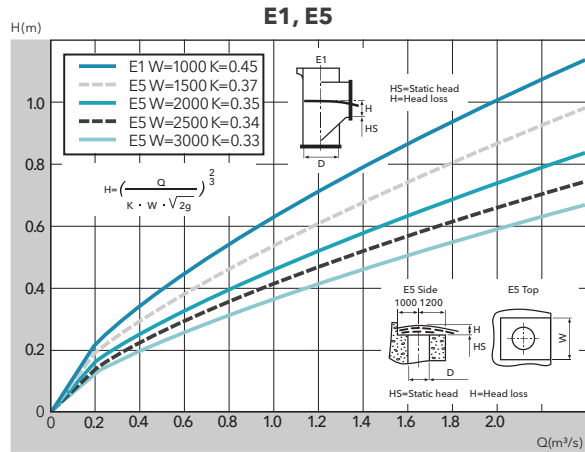
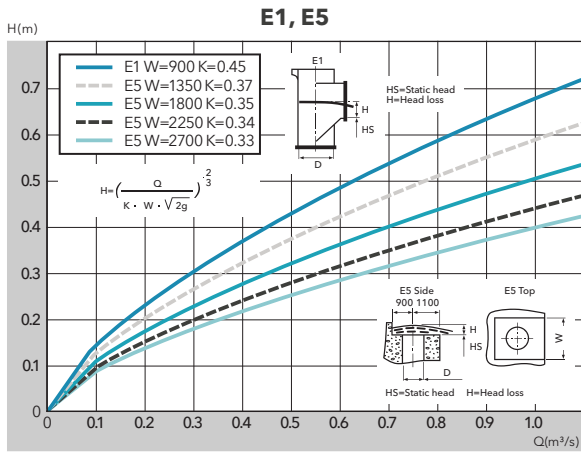

1200 mm Installation pipe inner diameter (D)  
**Flygt PL7101, PL7105, LL3531, LL3602**

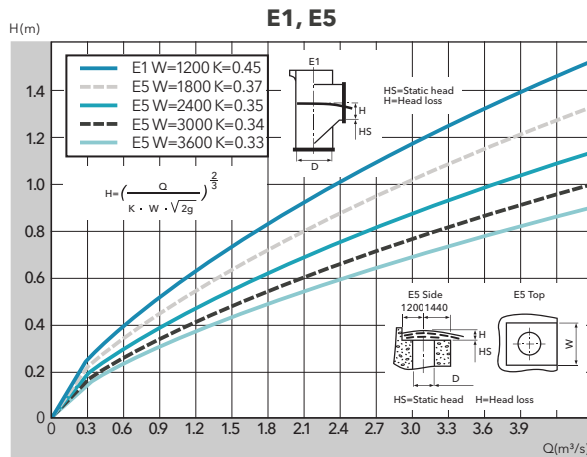

1400 mm Installation pipe inner diameter (D)  
**Flygt PL7115\*, PL7121, PL7125**

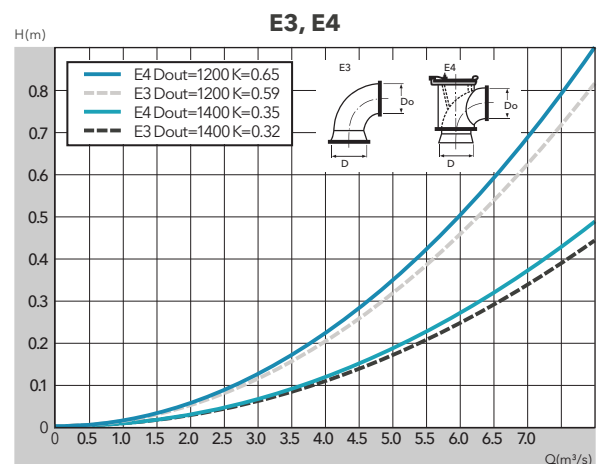
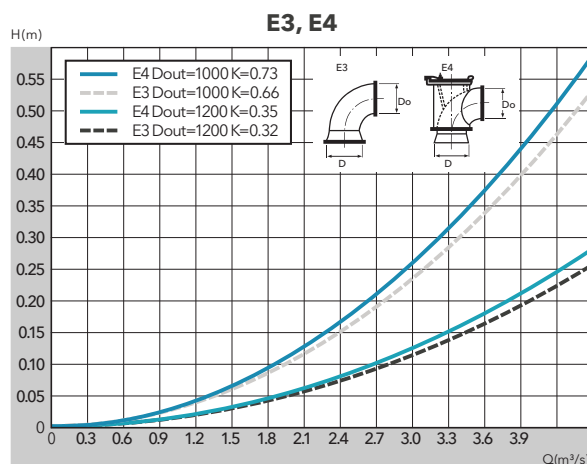
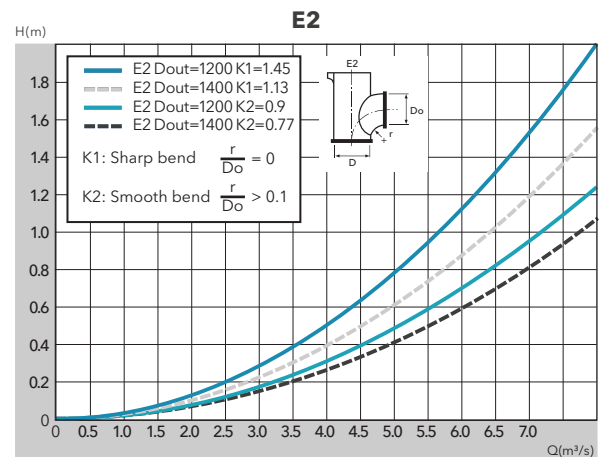
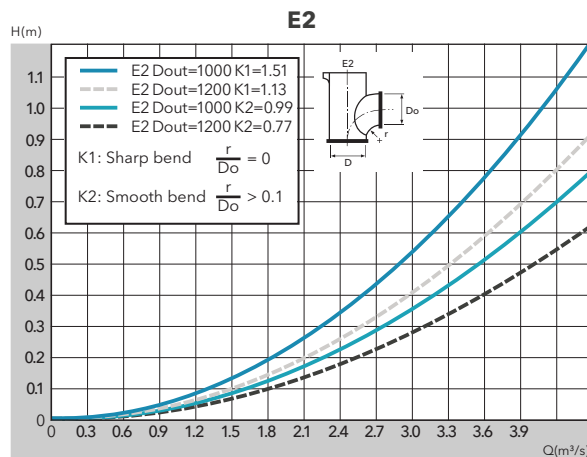
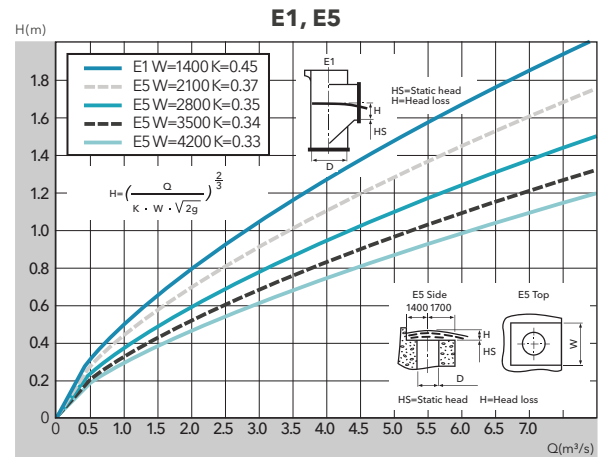

\* THESE PRODUCTS ARE OBSOLETE.

Irrigation with Flygt axial flow pumps

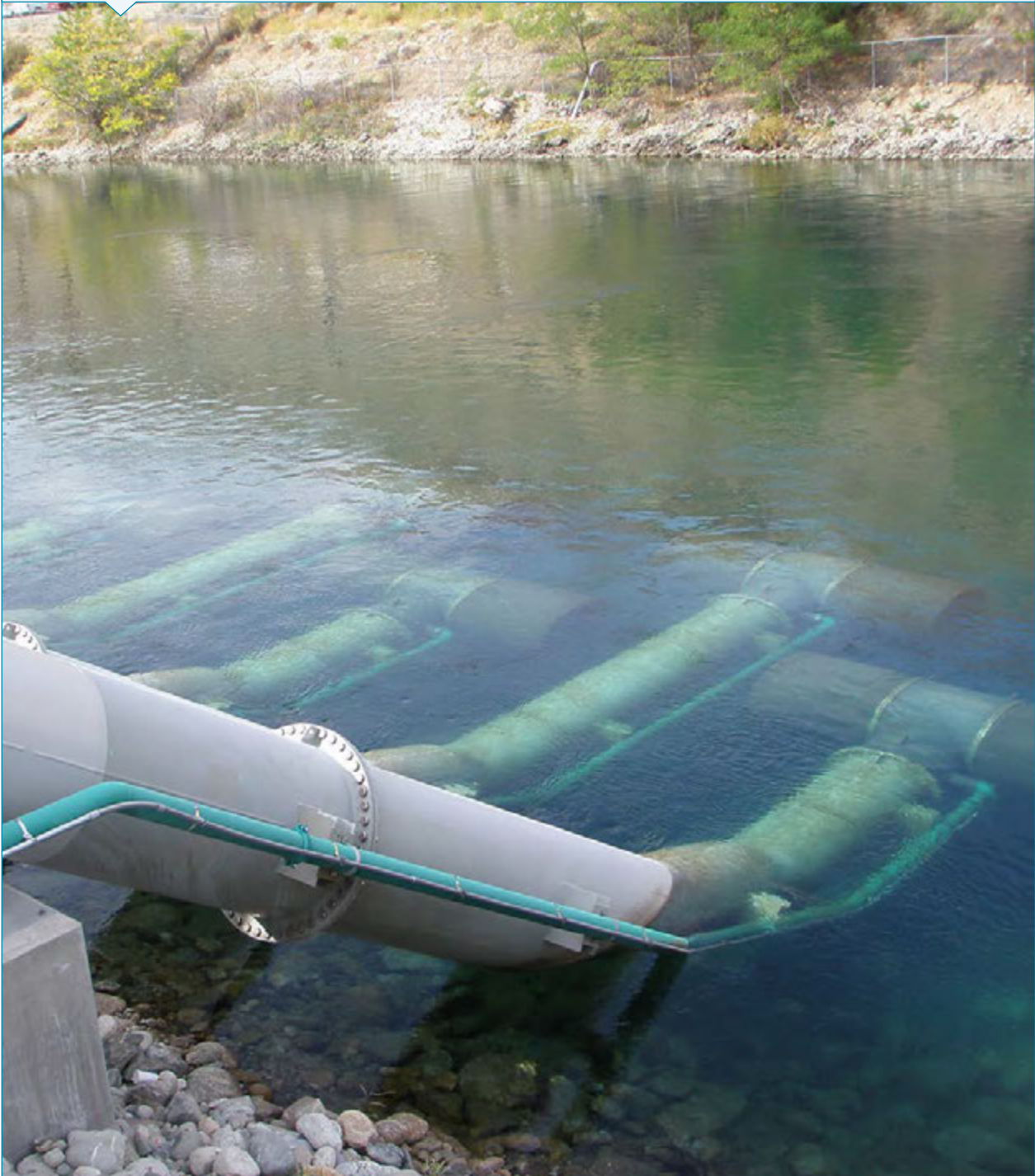

Propeller pumps (PL pumps) can be installed in many types of configurations.



## A | PROPELLER PUMP STATION DESIGNS

The following diagrams illustrate the standard designs that can be generated using the SECAD software from Xylem. SECAD allows for the quick and easy generation of tested station designs that can be used in either a PDF or CAD format.

Stations with low level front inlet

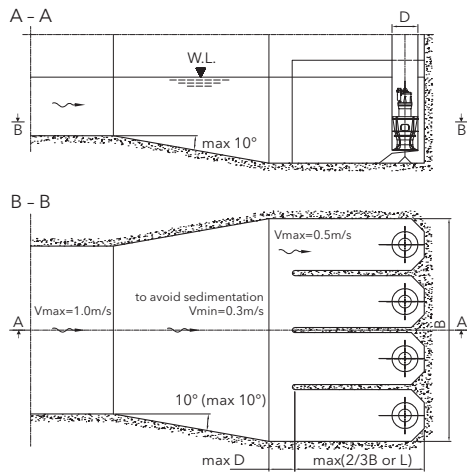

Stations with high level front inlet (max 4 pumps)

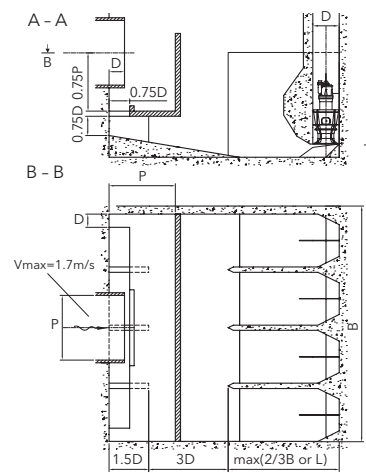

Stations with low level side inlet (max 4 pumps)

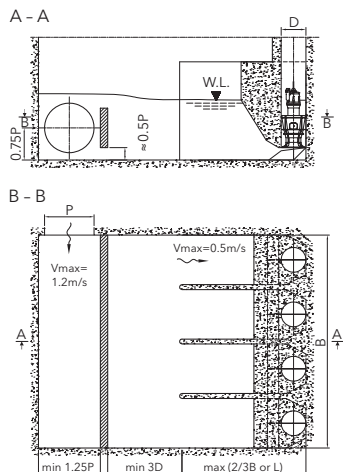

Stations with high level side inlet (max 4 pumps)

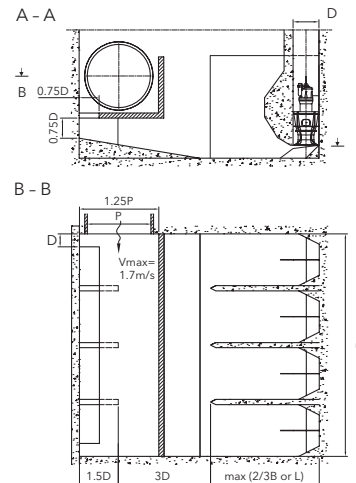

Details on the different types of pump bays are displayed below. These pump bays are included in SECAD and can be combined with the appropriate types of station design layouts shown above.

**Contact your local Xylem representative with questions regarding which type of pump bay is appropriate for your pump station layout.**

### Open sump design for Flygt PL pumps

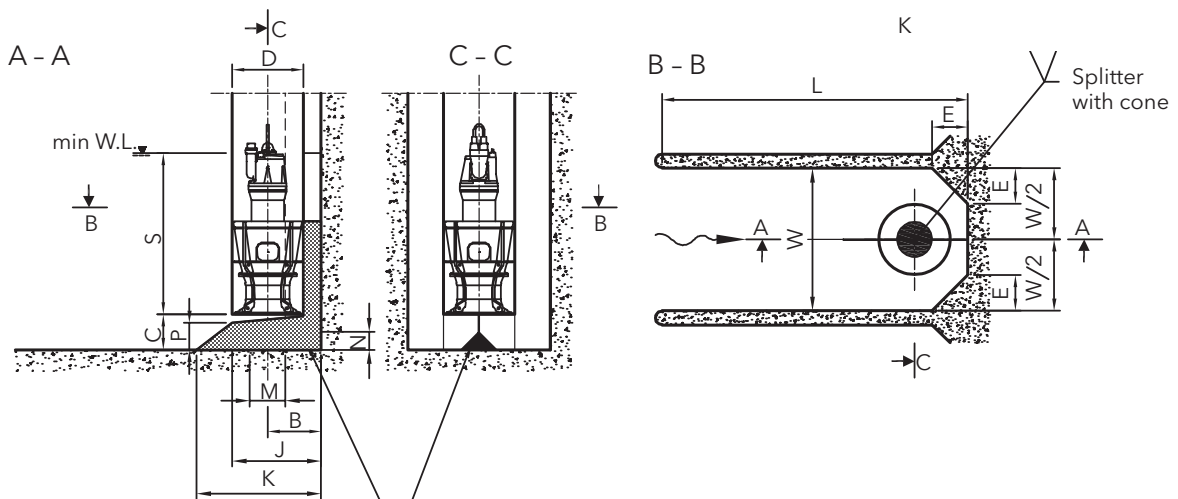

### Recommended dimensions

	Pump type	Nom. dia (mm)	B	C	D	E	J	K	L	M	N	P	S	W
Open Sump Intake Design	PL7020	400	0.30	0.20	0.40	0.20	0.50	0.70	1.60	0.20	0.10	0.15	See Minimum Submergence Diagram	0.80
	PL7030	500	0.38	0.25	0.50	0.25	0.63	0.88	2.00	0.25	0.13	0.19		1.00
	PL7035	550	0.41	0.28	0.55	0.28	0.69	0.96	2.20	0.28	0.14	0.21		1.10
	PL3127* PL7040	600	0.45	0.30	0.60	0.30	0.75	1.05	2.40	0.30	0.15	0.23		1.20
	PL7045* PL7050*	700	0.53	0.35	0.70	0.35	0.88	1.23	2.80	0.35	0.18	0.27		1.40
	PL7055* PL7061 PL7065	800	0.60	0.40	0.80	0.40	1.00	1.40	3.20	0.40	0.20	0.30		1.60
	PL7076 PL7081	1000	0.75	0.50	1.00	0.50	1.25	1.75	4.00	0.50	0.25	0.38		2.00
	PL7101 PL7105	1200	0.90	0.60	1.20	0.60	1.50	2.10	4.80	0.60	0.30	0.46		2.40
	PL7121 PL7125	1400	1.05	0.70	1.40	0.70	1.75	2.45	5.60	0.70	0.35	0.53		2.80

\* THESE PRODUCTS ARE OBSOLETE.

### Low level front inlet and pumps installed in FSI

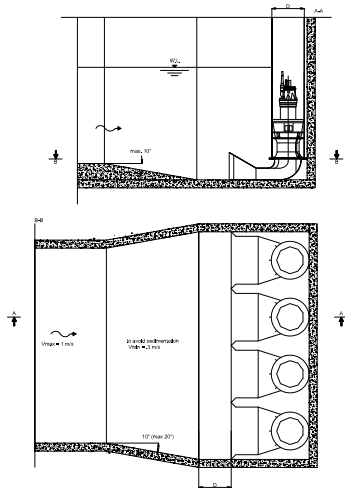

### High level front inlet and pumps installed in FSI

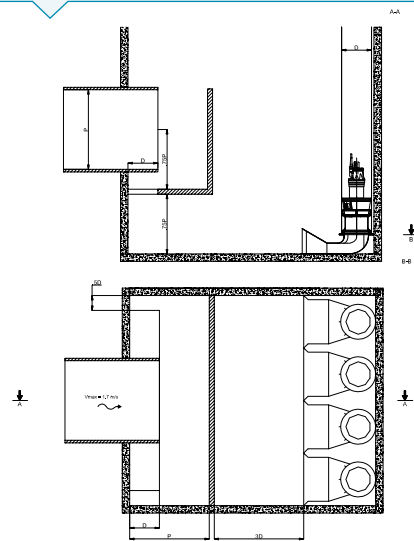

### Low level side inlet and pumps installed in FSI

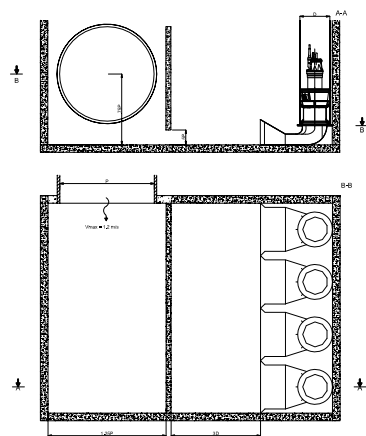

### High level side inlet and pumps installed in FSI

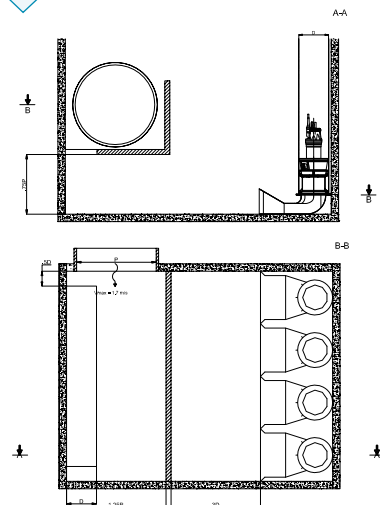

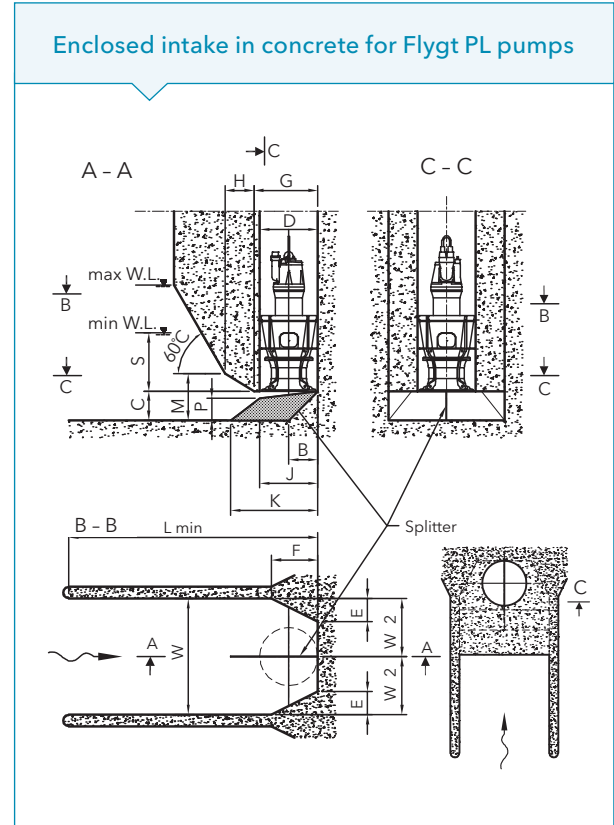
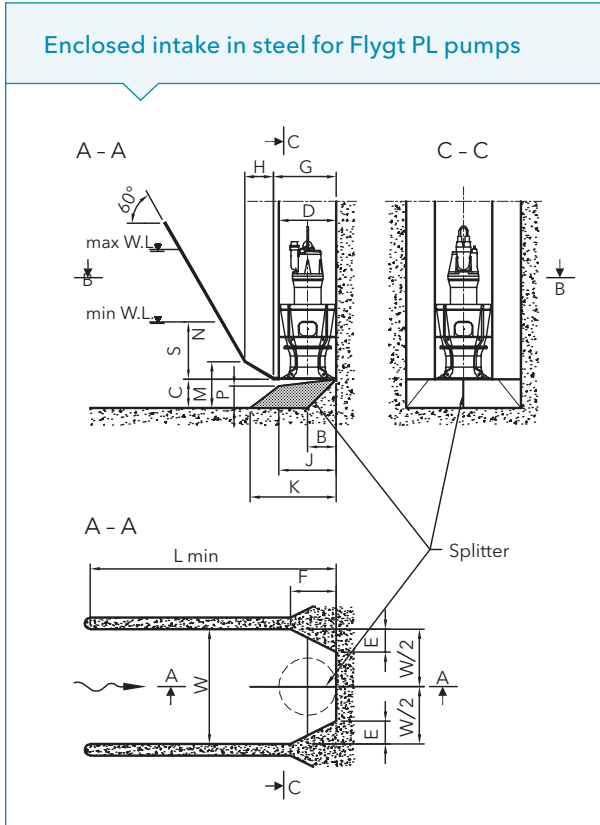

## Recommended dimensions

Pump type	Nom. dia (mm)	B	C	D	E	F	G	H	J	K	L	M	P	S	W
PL7020	400	0.20	0.20	0.40	0.16	0.32	0.44	0.20	0.40	0.60	1.60	0.32	0.15	0.40	0.80
PL7030	500	0.25	0.25	0.50	0.20	0.40	0.55	0.25	0.50	0.75	2.00	0.40	0.19	0.50	1.00
PL7035	550	0.28	0.28	0.55	0.22	0.44	0.61	0.28	0.55	0.83	2.20	0.44	0.21	0.55	1.10
PL7040	600	0.30	0.30	0.60	0.24	0.48	0.66	0.30	0.60	0.90	2.40	0.48	0.23	0.60	1.20
PL7050*	700	0.35	0.35	0.70	0.28	0.56	0.77	0.35	0.70	1.05	2.80	0.56	0.27	0.70	1.40
PL7055*															
PL7061	800	0.40	0.40	0.80	0.32	0.64	0.88	0.40	0.80	1.20	3.20	0.64	0.30	0.80	1.60
PL7065															
PL7076	1000	0.50	0.50	1.00	0.40	0.80	1.10	0.50	1.00	1.50	4.00	0.80	0.38	1.00	2.00
PL7081															
PL7101	1200	0.60	0.60	1.20	0.48	0.96	1.32	0.60	1.20	1.80	4.80	0.96	0.46	1.50	2.40
PL7105															
PL7121	1400	0.70	0.70	1.40	0.56	1.12	1.54	0.70	1.40	2.10	5.60	1.12	0.53	1.75	2.80
PL7125															

## Flygt FSI

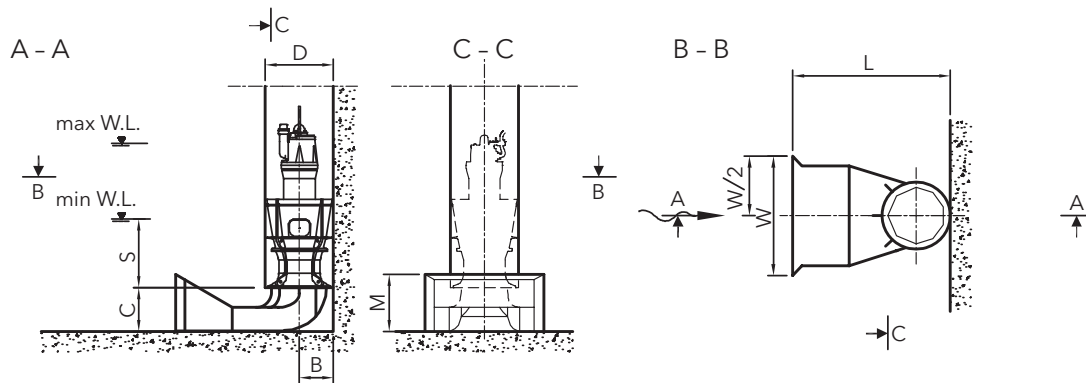

### Recommended dimensions

Pump type	Nom. dia (mm)	B	C	D	L	M	S	W	
Flygt FSI	PL7020	400	0.20	0.35	0.40	0.92	0.50	0.71	0.83
	PL7030	500	0.25	0.43	0.50	1.13	0.59	0.79	1.01
	PL7035	550	0.28	0.50	0.55	1.32	0.69	0.85	1.18
	PL7040	600	0.30	0.50	0.60	1.35	0.69	0.91	1.18
	PL7050*	700	0.35	0.40	0.70	1.49	0.53	0.70	1.11
	PL7055*								
	PL7061 PL7065	800	0.40	0.70	0.80	1.77	0.89	0.80	1.54
	PL7076 PL7081	1000	0.50	0.84	1.00	2.20	1.08	1.00	1.91
	PL7101 PL7105	1200	0.60	1.00	1.20	2.64	1.28	1.50	2.27
	PL7121 PL7125	1400	0.70	1.14	1.40	3.07	1.47	1.75	2.63



THESE PRODUCTS ARE OBSOLETE.

## B | MIXED FLOW PUMP STATION DESIGNS

Mixed flow pumps (LL) can be installed in similar station designs to Propeller pumps (PL). Mixed flow pumps are slightly more resilient to station hydraulics than propeller pumps, so in most cases the requirements for a station are slightly less demanding than for a propeller pump station. Xylem's SECAD also includes pump station designs for mixed flow pumps.

Flygt LL pumps

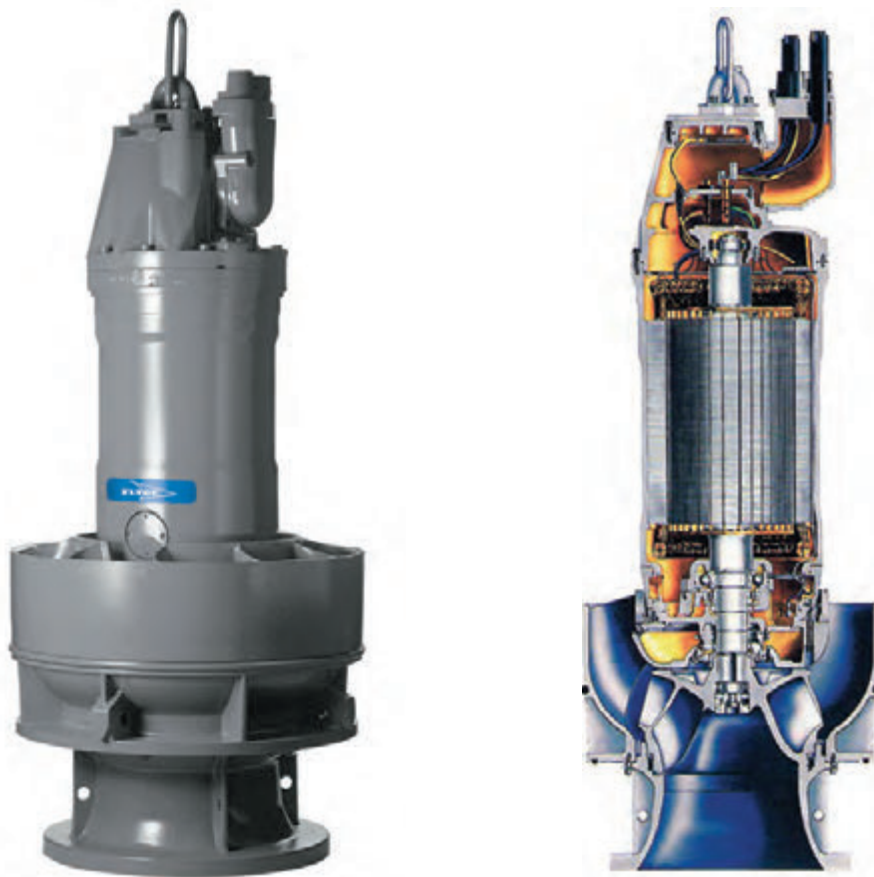

### Open sump design for Flygt LL pumps

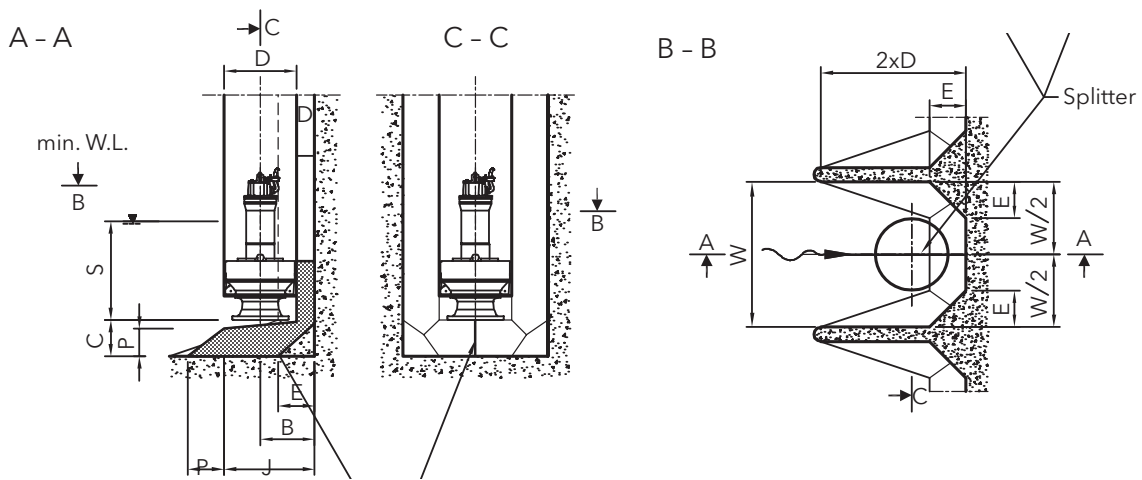

### Recommended dimensions

Pump type		Nom. dia (mm)	B	C	D	E	J	K	L	M	N	P	S	W	
Open Sump Intake Design	LL3085*	500	0.38	0.25	0.50	0.25	0.63	0.88	1.00	0.25	0.13	0.19	See Minimum Submergence Diagram	1.00	
	LL/NL3102														
	LL/NL3127	600	0.45	0.30	0.60	0.30	0.75	1.05	1.20	0.30	0.15	0.23		1.20	
	LL3152														
	LL3201	800	0.60	0.40	0.80	0.40	1.00	1.40	1.60	0.40	0.20	0.30		1.60	
	LL/NL3300														
LL3356															
	LL3400	900	0.68	0.45	0.90	0.45	1.13	1.58	1.80	0.45	0.23	0.34	1.80		
	LL3602	1200	0.90	0.60	1.20	0.60	1.50	2.10	2.40	0.60	0.30	0.46	2.40		



THESE PRODUCTS ARE OBSOLETE.

#### Free standing

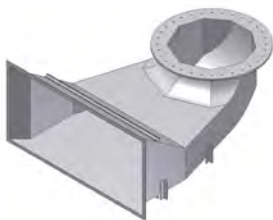

#### Encased in concrete with structural ribbing

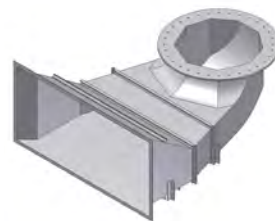

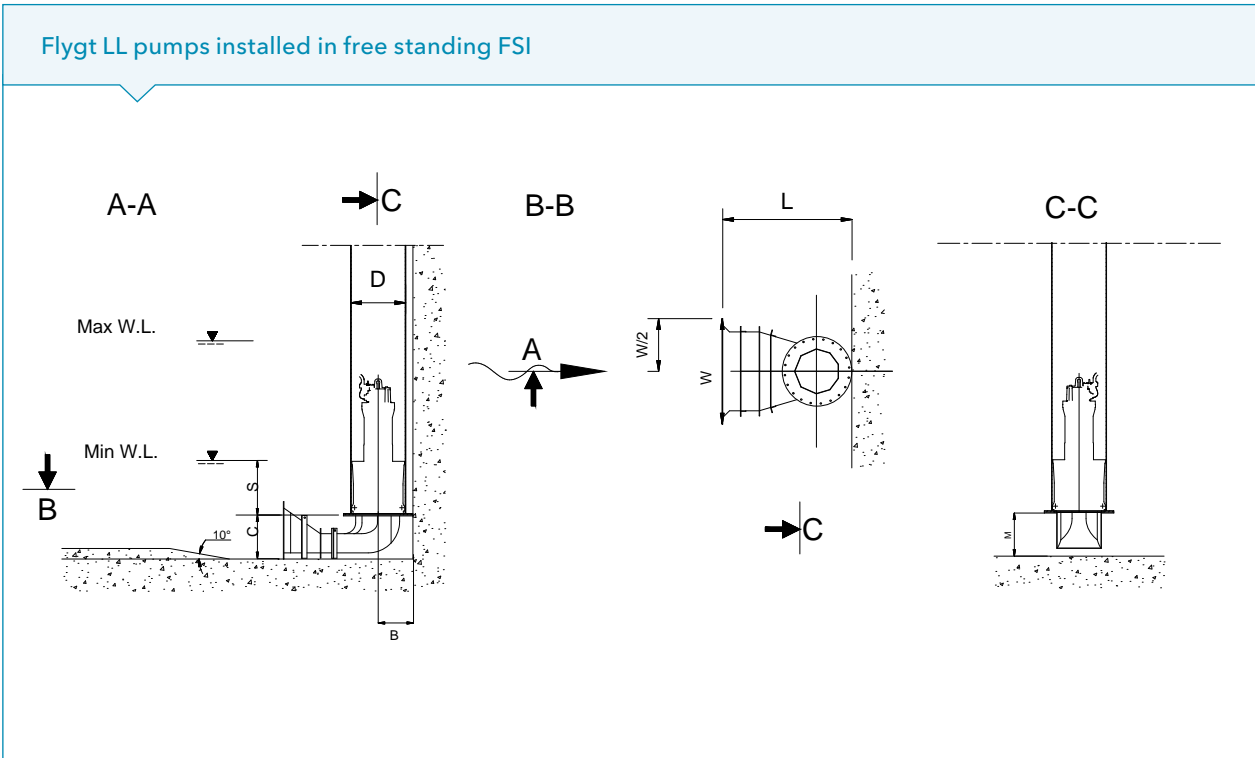

Recommended dimensions

	Pump type	Nom. dia (mm)	B	C	D	L	M	S	W
Flygt FSI	LL3085*	500	0.25	0.3	0.5	1.2	0.41	0.5	0.86
	LL/NL3102								
	LL/NL3127	600	0.3	0.4	0.6	1.3	0.45	0.6	0.94
	LL3152								
	LL3201	800	0.4	0.6	0.8	1.75	0.63	0.8	1.32
	LL/NL3300								
LL3356									
LL3400	900	0.5	0.6	1	2.28	0.83	0.9	1.73	
LL3602	1200	0.6	0.8	1.2	2.74	1	1.1	2.09	

\* THESE PRODUCTS ARE OBSOLETE.

## C | ULTRA-LOW HEAD PROPELLER PUMP STATION DESIGNS

Efficient flow generation, low specific energy consumption and minimal power demand are the principal benefit of Flygt ultra-low-head, high-flow pumps. These pumps have a proven history of successful installations worldwide wherever there is a need for large flow at low head conditions. Proper installation is crucial for a reliable and efficient operation. The following section presents guidelines for correct placement of the pumps and a means to calculate outlet loss, which is most often the major loss in this type of installation. Friction loss from long pipe runs and losses from other system components (valves, etc.) should be determined as well.

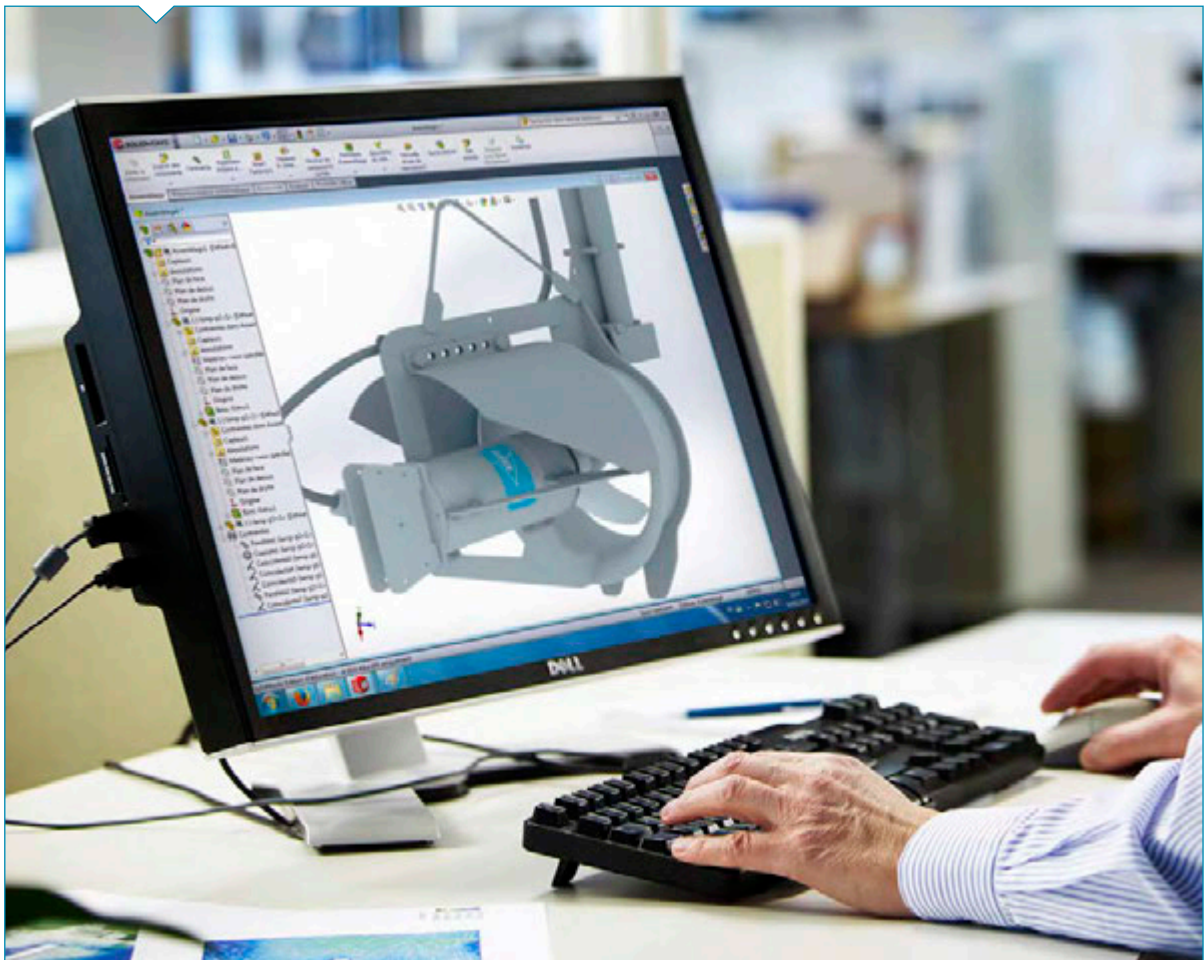

# C1

## FLYGT LOW HEAD PROPELLER PUMP APPLICATION

Typically, this kind of pump installation is used to pump water from one basin to another in wastewater treatment plants, recirculate wastewater and pump sludge (often with a variable speed drive). It can also be used to empty large buffer tanks, such as stormwater detention basins, and pump water in irrigation ditches. It has even been used to transport sea water into a bay for oyster farming, or into a harbor to improve water conditions. Another enjoyable application is for boat rides in amusement parks.

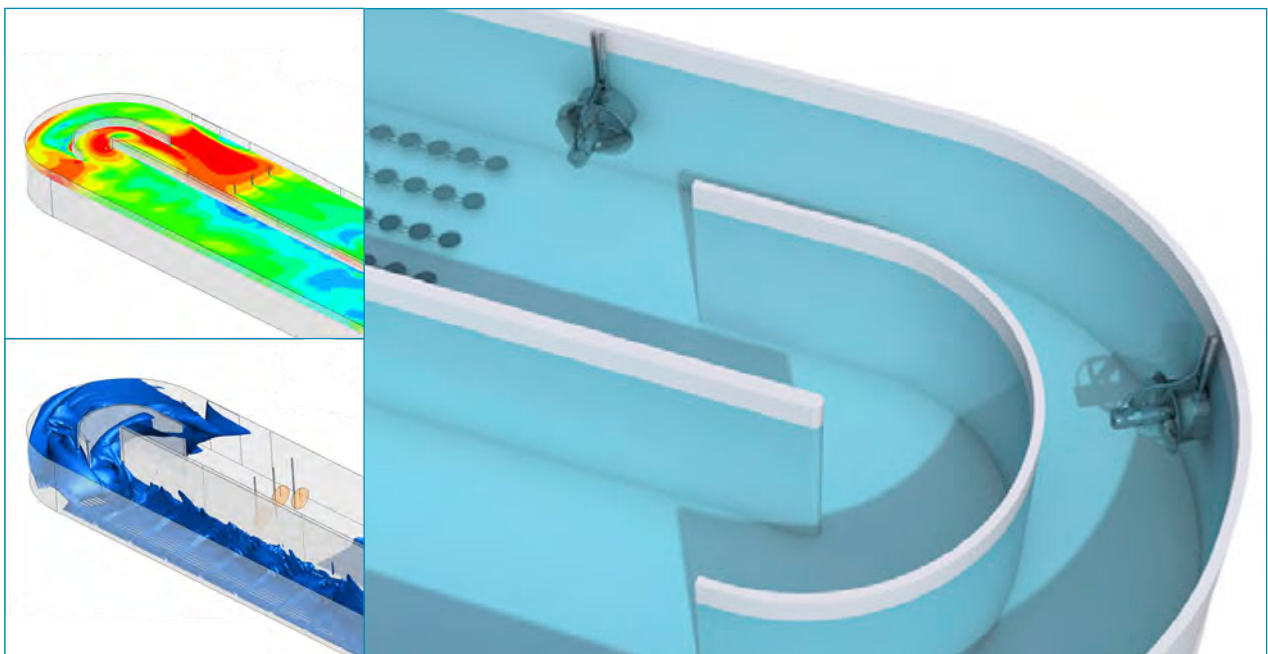

As with all pump stations, ensure the flow at the pump inlet is uniform and steady, and void of swirl, vortices and entrained air:

- | Non-uniform flow at the pump intake can reduce efficiency, cause pulsating loads and produce both noise and vibrations.
- | Vortices emanating from the free surface can become strong enough to draw air and floating debris into the pump. Vortices originating at solid surfaces can cavitate and release air into the pump.
- | Entrained air can reduce the pump flow and efficiency and it can cause vibration and noise.

The guidelines are based on the assumptions that the approaching flow is steady and that the velocities in the approach are less than 0.5 m/s. Eliminate obstacles that may produce rotational wakes and avoid entrainment of air. The discharge pipe should be designed in the same way as for a centrifugal pump installation (i.e. no special consideration for Flygt PP pump installation).

# C2

## INSTALLATION DIMENSIONS

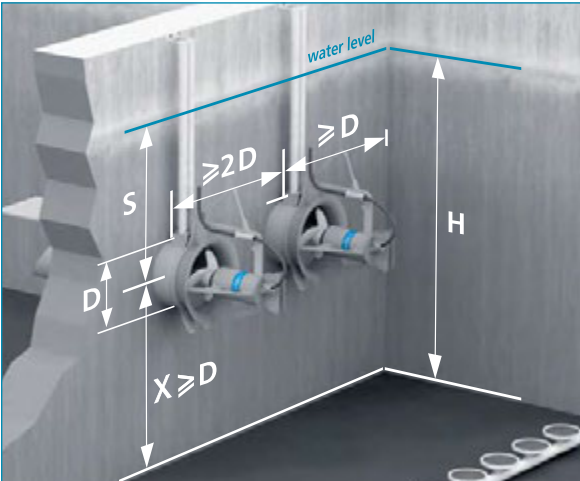

The adjacent guideline drawing can be used to determine the minimum distances for this type of pump installation.

Should your conditions differ please contact your Xylem representative for a satisfactory solution.

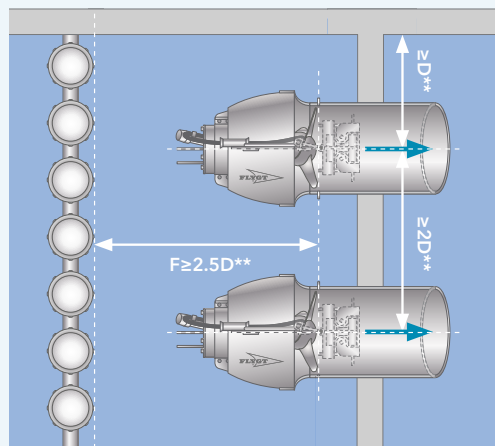
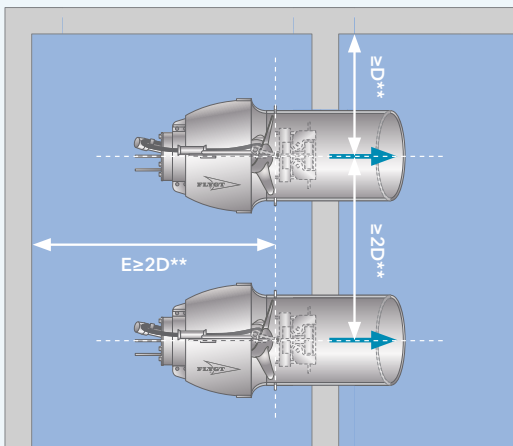
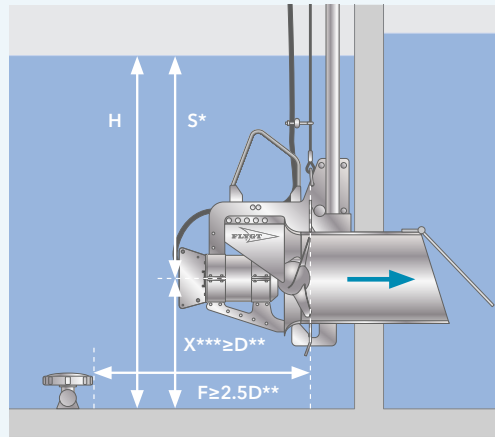
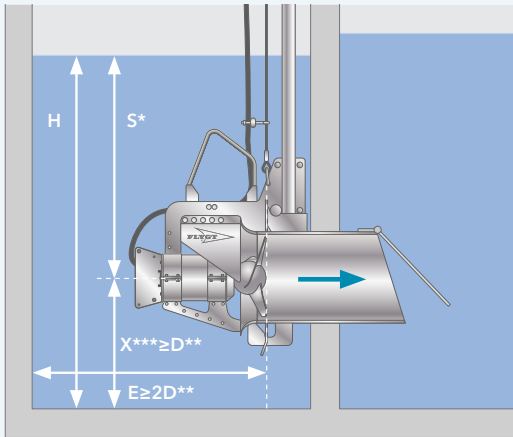

- \* Check the submergence diagram.
- \*\* Diameter of the discharge connection, see the head loss chart.
- \*\*\* Always consider the construction deviation and installation spacing according to your local regulations.

### C3

#### RACETRACK INSTALLATION

Typically, the best location for the pump is on a straight wall some distance away from the bend where flow conditions are stable.

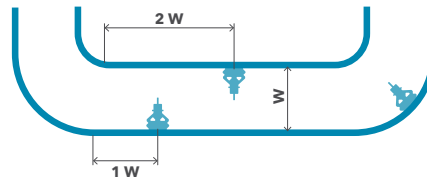

If the pumps must be placed in a bend or close to one, then they should be installed on the outside wall of the bend where fewer vortices occur.

### C4

#### SUBMERGENCE

The following diagram shows the minimum recommended submergence (S). In shallow tanks and tanks that have poor inflow conditions, it may be impossible to provide the amount of submergence specified in the guidelines above. In such cases, equip pumps with a vortex protection shield. These shields are designed to reduce the tendency to form vortices and swirl, and to make it possible to operate with less than the prescribed submergence.

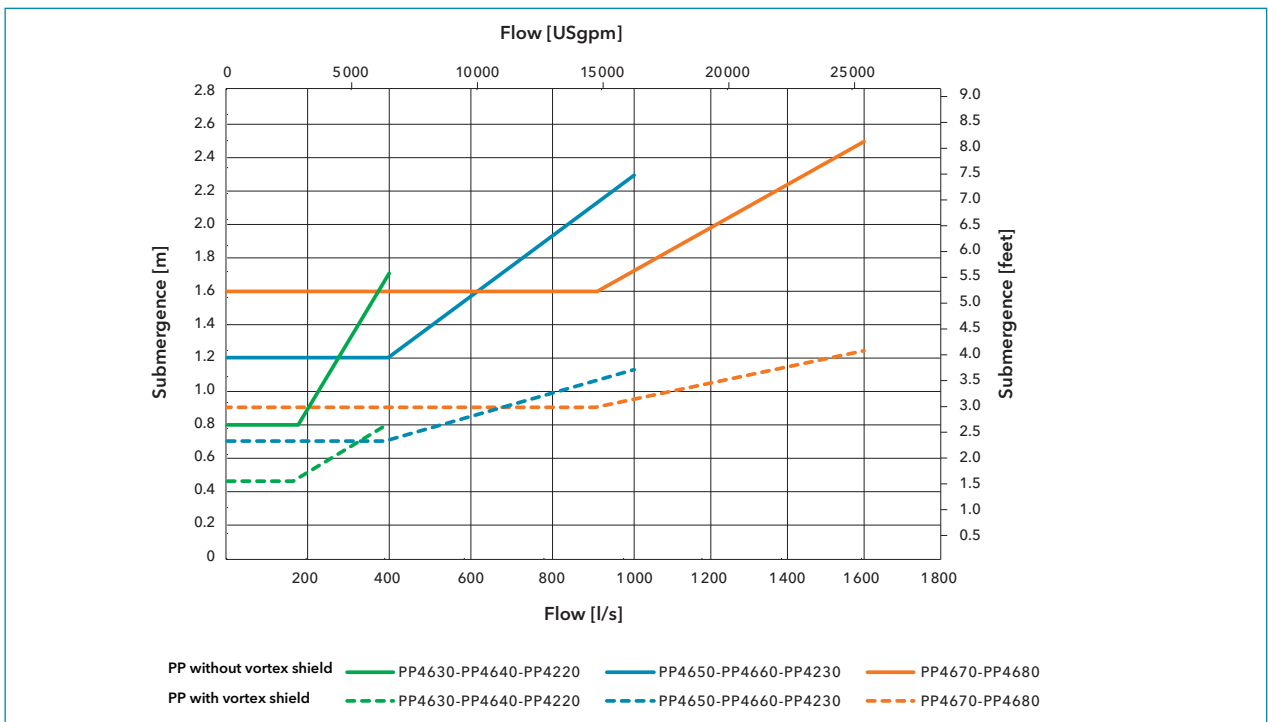

# C5

## OUTLET LOSSES

Compared to conventional pump installations, the outlet loss is more significant in this type of installation. Use the following tables to estimate this head loss for the installation.

Pump Model	D (Diameter of the discharge connection) [mm]	Q (Flow) [l/s]	Outlet head loss	
			(k=1) [m]	Non-return valve head loss (k=0.5) [m]
PP4630 PP4640 PP4220	400	200	0.13*	0.06
		250	0.20	0.10
		300	0.29	0.15
PP4650 PP4660 PP4230	600	400	0.10	0.05
		500	0.16	0.08
		600	0.23	0.11
		700	0.31	0.16
		800	0.41	0.20
PP4670 PP4680	800	900	0.52	0.26
		1000	0.20	0.10
		1200	0.29	0.15
		1400	0.40	0.20
		1600	0.52	0.26

$$*h = 10^6 \times k \times \frac{(4Q/\pi D^2)^2}{2 \times g} \rightarrow h = 10^6 \times 1 \times \frac{(4 \times 200 / (3.14 \times 400^2))^2}{2 \times 9.81} = 0.12923 \cong 0.13 [m]$$

Pump Model	D (Diameter of the discharge connection) [inch]	Q (Flow) [USgpm]	Outlet head loss	
			(k=1) [inch]	Non-return valve head loss (k=0.5) [inch]
PP4630 PP4640 PP4220	16	3000	4.3*	2.1
		4000	7.6	3.8
		5000	11.9	5.9
PP4650 PP4660 PP4230	24	6000	3.4	1.7
		8000	6.0	3.0
		10000	9.4	4.7
		12000	13.5	6.8
		14000	18.4	9.2
		16000	24.0	12.0
PP4670 PP4680	32(steel) or 30(CI/DI)	16000	7.6	3.8
		19000	10.7	5.4
		22000	14.4	7.2
		25000	18.6	9.3

$$*h = k \times \frac{(4Q/\pi D^2)^2}{2 \times g} \rightarrow h = 1 \times \frac{4 \times \frac{3000}{448.83} / (3.14 \times (\frac{16}{12})^2)^2}{2 \times 32.17} = \frac{(4.789)^2}{2 \times 32.17} = 0.357 ft \cong 4.3 [in]$$





# Xylem |'zīləm|

- 1) The tissue in plants that brings water upward from the roots;
- 2) a leading global water technology company.

We're a global team unified in a common purpose: creating advanced technology solutions to the world's water challenges. Developing new technologies that will improve the way water is used, conserved, and re-used in the future is central to our work. Our products and services move, treat, analyze, monitor and return water to the environment, in public utility, industrial, residential and commercial building services settings. Xylem also provides a leading portfolio of smart metering, network technologies and advanced analytics solutions for water, electric and gas utilities. In more than 150 countries, we have strong, long-standing relationships with customers who know us for our powerful combination of leading product brands and applications expertise with a strong focus on developing comprehensive, sustainable solutions.

**For more information on how Xylem can help you, go to [www.xylem.com](http://www.xylem.com).**



Xylem, Inc.  
1 International Drive  
Rye Brook, NY 10573  
United States  
1-914-323-5700  
[www.xylem.com](http://www.xylem.com)

Flygt is a trademark of Xylem Inc. or one of its subsidiaries.  
© 2022 Xylem, Inc. March 2022